



High-Efficiency, PWM, Step-Down, N-Channel DC-DC Controller

MAX746

General Description

The MAX746 is a high-efficiency, high-current, step-down DC-DC power-supply controller that drives external N-channel FETs. It provides 93% to 96% efficiency from a 6V supply voltage with load currents ranging from 50mA up to 3A. It uses a pulse-width-modulating (PWM) current-mode control scheme to provide precise output regulation and low output noise. The MAX746's 4V to 15V input voltage range, fixed 5V/adjustable (Dual-Mode™) output, and adjustable current limit make this device ideal for a wide range of applications.

High efficiency is maintained with light loads due to a proprietary automatic pulse-skipping control (Idle-Mode™) scheme that minimizes switching losses by reducing the switching frequency at light loads. The low 950µA quiescent current and ultra-low 1.4µA shutdown current further extend battery life.

External components are protected by the MAX746's cycle-by-cycle current limit. The MAX746 also features a 2V ±1.5% reference, a comparator for low-battery detection or level translating, and soft-start and shutdown capability.

The MAX747—discussed in a separate data sheet—functions similarly to the MAX746, but drives P-channel logic level FETs.

Applications

5V-to-3.3V Green PC Applications
 Notebook/Laptop Computers
 Personal Digital Assistants
 Battery-Operated Equipment
 Cellular Phones

Typical Operating Circuit

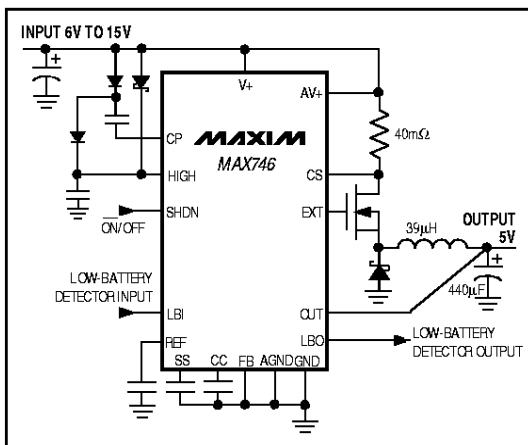

™Dual-Mode and Idle-Mode are trademarks of Maxim Integrated Products.

Features

- ◆ 93% to 96% Efficiency for 50mA to 3A Output Currents
- ◆ 4V to 15V Input Voltage Range
- ◆ Low 950µA Supply Current
- ◆ 1.4µA Shutdown Current
- ◆ Drives External N-Channel FETs
- ◆ Fixed-Frequency Current-Mode PWM (Heavy Loads)
- ◆ Idle-Mode PFM (Light Loads)
- ◆ Cycle-by-Cycle Current Limiting
- ◆ 2V ±1.5% Accurate Reference Output
- ◆ Adjustable Soft-Start
- ◆ Undervoltage Lockout
- ◆ Precision Comparator for Power-Fail or Low-Battery Warning

Ordering Information

PART	TEMP. RANGE	PIN-PACKAGE
MAX746CPE	0°C to +70°C	16 Plastic DIP
MAX746CSE	0°C to +70°C	16 Narrow SO
MAX746C/D	0°C to +70°C	Dice*
MAX746EPE	-40°C to +85°C	16 Plastic DIP
MAX746ESE	-40°C to +85°C	16 Narrow SO
MAX746MJE	-55°C to +125°C	16 CERDIP

* Contact factory for dice specifications.

Pin Configuration

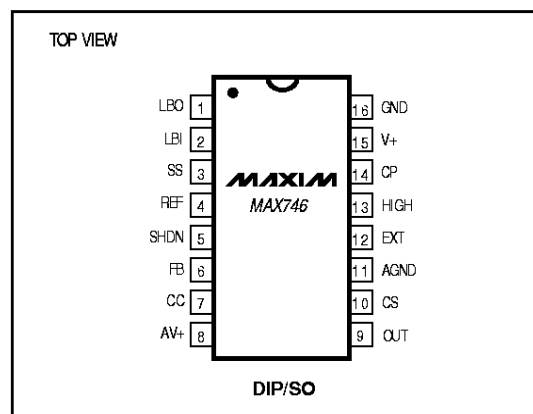

High-Efficiency, PWM, Step-Down, N-Channel DC-DC Controller

MAX746

ABSOLUTE MAXIMUM RATINGS

Supply Voltage V_+ , AV+ to GND	-0.3V to 17V	Operating Temperature Ranges:	
HIGH, EXT to GND	-0.3V to 21V	MAX746C_E	0°C to +70°C
AGND to GND	-0.3V to 0.3V	MAX746E_E	-40°C to +85°C
All Other Pins	-0.3V to (V_+ + 0.3V)	MAX746MJE	-55°C to +125°C
Reference Current (I_{REF})	±2mA	Junction Temperatures:	
Continuous Power Dissipation ($T_A = +70^\circ\text{C}$)		MAX746C_E/E_E	+150°C
Plastic DIP (derate 10.53mW/°C above +70°C)	842mW	MAX746MJE	+175°C
Narrow SO (derate 8.70mW/°C above +70°C)	696mW	Storage Temperature Range	-65°C to +160°C
CERDIP (derate 10.00mW/°C above +70°C)	800mW	Lead Temperature (soldering, 10sec)	+300°C

Stresses beyond those listed under "Absolute Maximum Ratings" may cause permanent damage to the device. These are stress ratings only, and functional operation of the device at these or any other conditions beyond those indicated in the operational sections of the specifications is not implied. Exposure to absolute maximum rating conditions for extended periods may affect device reliability.

ELECTRICAL CHARACTERISTICS

($V_+ = 10\text{V}$, $I_{LOAD} = 0\text{A}$, $I_{REF} = 0\mu\text{A}$, $T_A = T_{MIN}$ to T_{MAX} , unless otherwise noted.)

PARAMETER	SYMBOL	CONDITIONS	MIN	TYP	MAX	UNITS	
Input Voltage	V_+		4		15	V	
Output Voltage	V_{OUT}	$V_+ = 6\text{V}$ to 15V , $0\text{V} < (V_+ - CS) < 0.125\text{V}$, FB = 0V (includes line and load regulation)	4.85	5.08	5.25	V	
Feedback Voltage	V_{FB}	$(V_+ - CS) = 0\text{V}$, external feedback mode	MAX746C	1.96	2.00	2.04	V
			MAX746E/M	1.95	2.00	2.05	
Line Regulation		$V_+ = 6\text{V}$ to 15V , FB = 0V	0.05			%V	
		$V_+ = 4\text{V}$ to 15V , external feedback mode	0.1				
Load Regulation		$0\text{V} < (V_+ - CS) < 0.125\text{V}$		1.3	2.5	%	
Efficiency		Circuit of Figure 1, $I_{LOAD} = 0.5\text{A}$ to 2.5A , $V_+ = 6\text{V}$		94		%	
OUT Leakage Current		$V_{OUT} = 5\text{V}$		50	80	μA	
FB Input Logic Low		For dual-mode switchover			40	mV	
FB Input Leakage Current		FB = 2V		1	100	nA	
Reference Voltage	V_{REF}	$I_{REF} = 0\mu\text{A}$	MAX746C	1.97	2.00	2.03	V
			MAX746E/M	1.96	2.00	2.04	
Reference Load Regulation		$I_{REF} = 0\mu\text{A}$ to $100\mu\text{A}$		9	20	mV	
Soft-Start Source Current		SS = 0V	0.5	1.0	1.5	μA	
Soft-Start Fault Current (Note 1)		SS = 2V	100	500		μA	
Supply Current (Note 2)	I_{SUPP}	Operating, $V_+ = 15\text{V}$	MAX746C	1.1	1.4	mA	
			MAX746E/M		1.7		
		Operating, $V_+ = 10\text{V}$	0.95				
		Shutdown mode		1.4	20	μA	
Oscillator Frequency	f_{OSC}	MAX746C	85	100	115	kHz	
		MAX746E/M	80	100	120		

High-Efficiency, PWM, Step-Down, N-Channel DC-DC Controller

MAX746

ELECTRICAL CHARACTERISTICS (continued)

($V_+ = 10V$, $I_{LOAD} = 0A$, $I_{REF} = 0\mu A$, $T_A = T_{MIN}$ to T_{MAX} , unless otherwise noted.)

PARAMETER	SYMBOL	CONDITIONS	MIN	TYP	MAX	UNITS	
Maximum Duty Cycle		$V_+ = 6V$	91	96		%	
Charge-Pump Output Voltage	V_{HIGH}	$I_{HIGH} = 0mA$ to $10mA$	$V_+ + 4$	$V_+ + 5$	$V_+ + 6$	V	
Current-Sense Amplifier Current-Limit Threshold	V_{LIMIT}	$V_+ - CS$	125	150	175	mV	
EXT Output High		V_{HIGH} forced to $15V$, $I_{EXT} = -1mA$	$V_{HIGH} - 0.1$			V	
EXT Output Low		V_{HIGH} forced to $15V$, $I_{EXT} = 1mA$			0.25	V	
EXT Sink Current		$V_{HIGH} = 15V$, $V_{EXT} = 12.5V$		160		mA	
EXT Source Current		$V_{HIGH} = 15V$, $V_{EXT} = 2.5V$		270		mA	
Compensation Pin Impedance				24		k Ω	
LBI Threshold Voltage		LBI falling	MAX746C	1.97	2.00	2.03	V
			MAX746E/M	1.96	2.00	2.04	
LBO Output Voltage Low	V_{OL}	$I_{SINK} = 0.5mA$			0.4	V	
LBI Input Leakage Current		$LBI = 2.5V$			100	nA	
LBO Output Leakage Current		$V_+ = 15V$, $LBO = 15V$, $LBI = 2.5V$			1	μA	
SHDN Input Voltage Low	V_{IL}				0.4	V	
SHDN Input Voltage High	V_{IH}		2.0			V	
SHDN Input Leakage Current		$SHDN = 10V$		0.1	100	nA	

Note 1: The soft-start fault current is the current sink capability of SS when $V_{REF} < 1V$ or when the device is in shutdown.

Note 2: I_{SUPP} is the supply current drawn by V_+ , which includes the current drawn by the charge pump. The charge pump doubles the current drawn by HIGH from the V_+ input, so $I_{SUPP} = I_{V_+} + 2I_{HIGH}$.

High-Efficiency, PWM, Step-Down, N-Channel DC-DC Controller

Typical Operating Characteristics

(Circuit of Figure 1a, $T_A = +25^\circ\text{C}$, unless otherwise noted.)

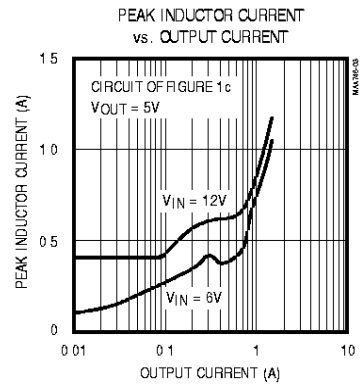
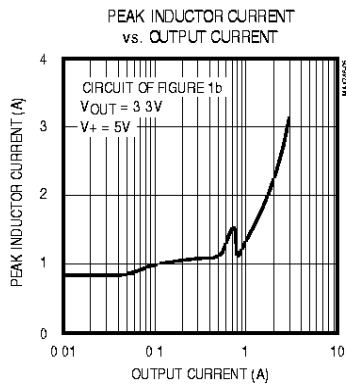
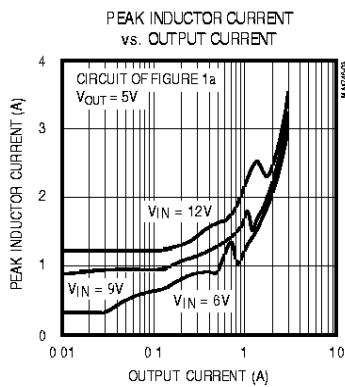
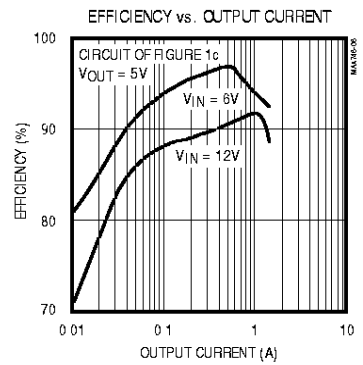
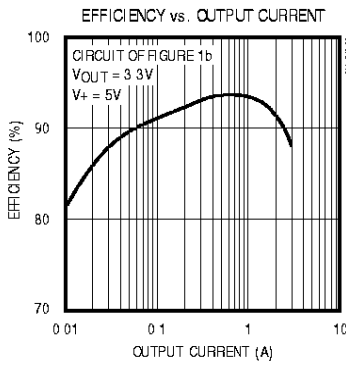
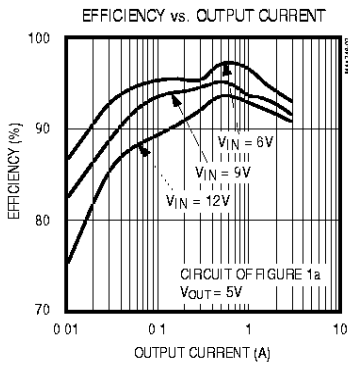
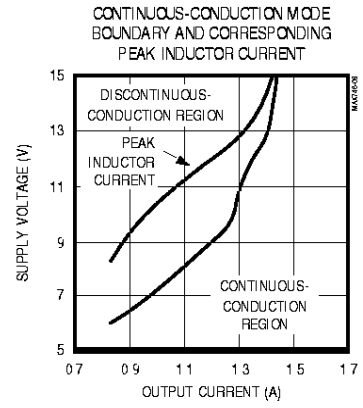
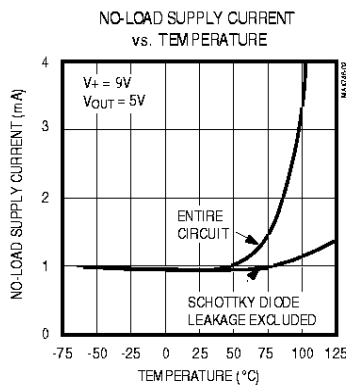
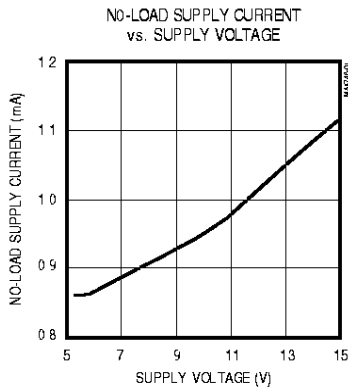

High-Efficiency, PWM, Step-Down, N-Channel DC-DC Controller

MAX746

Typical Operating Characteristics (continued)

(Circuit of Figure 1a, $T_A = +25^\circ\text{C}$, unless otherwise noted.)

LOAD-TRANSIENT RESPONSE

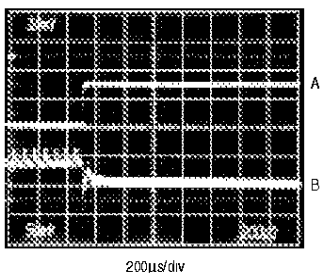

A LOAD CURRENT, 0 1A TO 1 5A, 1A/div
B V_{OUT} RIPPLE, 50mV/div, AC-COUPLED
 $V_+ = 10\text{V}$

LOAD-TRANSIENT RESPONSE

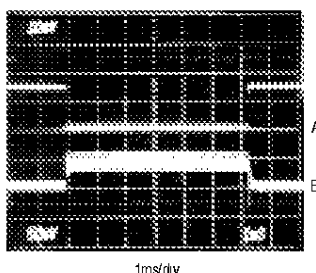

A LOAD CURRENT, 0 1A TO 1 5A, 1A/div
B V_{OUT} RIPPLE, 50mV/div, AC-COUPLED
 $V_+ = 10\text{V}$

LINE-TRANSIENT RESPONSE

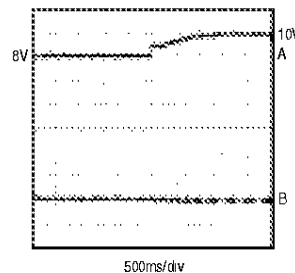

A $V_+ = 8\text{V TO } 10\text{V}$, 2V/div
B V_{OUT} RIPPLE, 100mV/div
 $I_{OUT} = 3\text{A}$

CONTINUOUS-CONDUCTION MODE WAVEFORMS

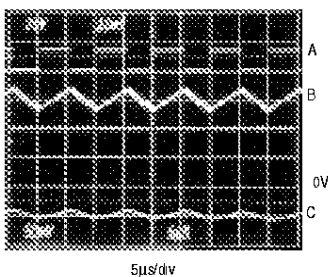

A EXT VOLTAGE, 20V/div
B INDUCTOR CURRENT, 1A/div
C V_{OUT} RIPPLE, 50mV/div
 $V_+ = 10\text{V}$, $I_{OUT} = 3\text{A}$

DISCONTINUOUS-CONDUCTION IDLE-MODE WAVEFORMS

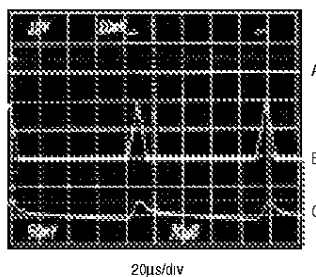

A EXT VOLTAGE, 10V/div
B INDUCTOR CURRENT, 500mA/div
C V_{OUT} RIPPLE, 50mV/div, AC-COUPLED
 $V_+ = 10\text{V}$, $I_{OUT} = 75\text{mA}$

MODERATE-LOAD, IDLE-MODE WAVEFORMS

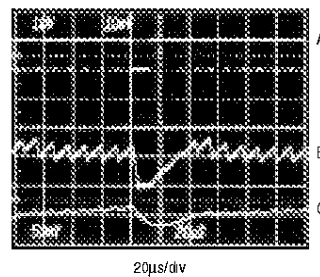

A EXT VOLTAGE, 10V/div
B INDUCTOR CURRENT, 500mA/div
C V_{OUT} RIPPLE, 50mV/div, AC-COUPLED
 $V_+ = 8\text{V}$, $I_{OUT} = 480\text{mA}$

High-Efficiency, PWM, Step-Down, N-Channel DC-DC Controller

Pin Description

PIN	NAME	FUNCTION
1	LBO	Low-battery output is an open-drain output that goes low when LBI is less than 2V. Connect to V+ through a pull-up resistor. Leave floating if not used. LBO is disabled in shutdown mode.
2	LBI	Input to the low-battery comparator. Tie to V+ or GND if not used.
3	SS	Soft-start limits start-up surge currents. On power-up, it charges the soft-start capacitor, slowly raising the peak current limit to the level set by the sense resistor.
4	REF	2V reference output can source 100 μ A for external loads. Bypass with 1 μ F. The reference is disabled in shutdown mode.
5	SHDN	Active-high logic input. In shutdown mode, V _{OUT} = 0V and the supply current is reduced to less than 20 μ A. Connect to GND for normal operation.
6	FB	Feedback input for adjustable-output operation. Connect to GND for fixed 5V output. Use a resistor-divider network to adjust the output voltage (see <i>Setting the Output Voltage</i> section).
7	CC	AC compensation input for the error amplifier. Connect a capacitor between CC and GND for fixed 5V-output operation (see <i>Compensation Capacitor</i> section).
8	AV+	Quiet supply voltage for sensitive analog circuitry. Also the noninverting input to the current-sense amplifier. A separate bypass capacitor is not recommended for AV+.
9	OUT	Output voltage sense that connects to the internal resistor divider. Bypass with 0.1 μ F to AGND, close to the IC for fixed output operation. Leave unconnected for adjustable-output operation.
10	CS	Inverting input to the current-sense amplifier. Connect the current-sense resistor (R _{SENSE}) from AV+ to CS.
11	AGND	Quiet analog ground.
12	EXT	Power MOSFET gate-drive output that swings between HIGH and GND. EXT is not protected against short circuits to V+ or AGND.
13	HIGH	Regulated high-side voltage, 5V above the V+ supply voltage.
14	CP	Charge-pump output that generates a 0V to V+, 50kHz square wave (see <i>Charge Pump</i> section).
15	V+	High-current supply voltage for the charge pump.
16	GND	High-current ground return for the output driver and charge pump.

Getting Started

Figure 1a shows the 5V-output 3A standard application circuit, Figure 1b shows the 3.3V-output 3A standard application circuit, and Figure 1c shows the 5V-output 1.5A standard application circuit. Most applications will be served by these circuits. To learn more about component selection for particular applications, refer to the *Design Procedure* section. To learn more about the operation of the MAX746, refer to the *Detailed Description*.

Detailed Description

The MAX746 monolithic, CMOS, step-down, switch-mode power-supply controller provides high-side drive for external logic-level N-channel FETs. A charge pump generates a voltage 5V above the supply voltage for high-side drive capability. The MAX746 uses a unique

current-mode pulse-width-modulating (PWM) control scheme that results in tight output-voltage regulation, excellent load- and line-transient response, low noise, and high efficiency over a wide range of load currents. Efficiency at light loads is further enhanced by a proprietary idle-mode switching control scheme that skips oscillator cycles in order to reduce switching losses. Other features include undervoltage lockout, shutdown, and a low-battery detection comparator.

Operating Principle

Figure 2 is the MAX746 block diagram. The MAX746 regulates using an inner current-feedback loop and an outer voltage-feedback loop. A slope-compensation scheme stabilizes the current loop; the dominant pole, formed by the output filter capacitor and the load, stabilizes the voltage loop.

High-Efficiency, PWM, Step-Down, N-Channel DC-DC Controller

MAX746

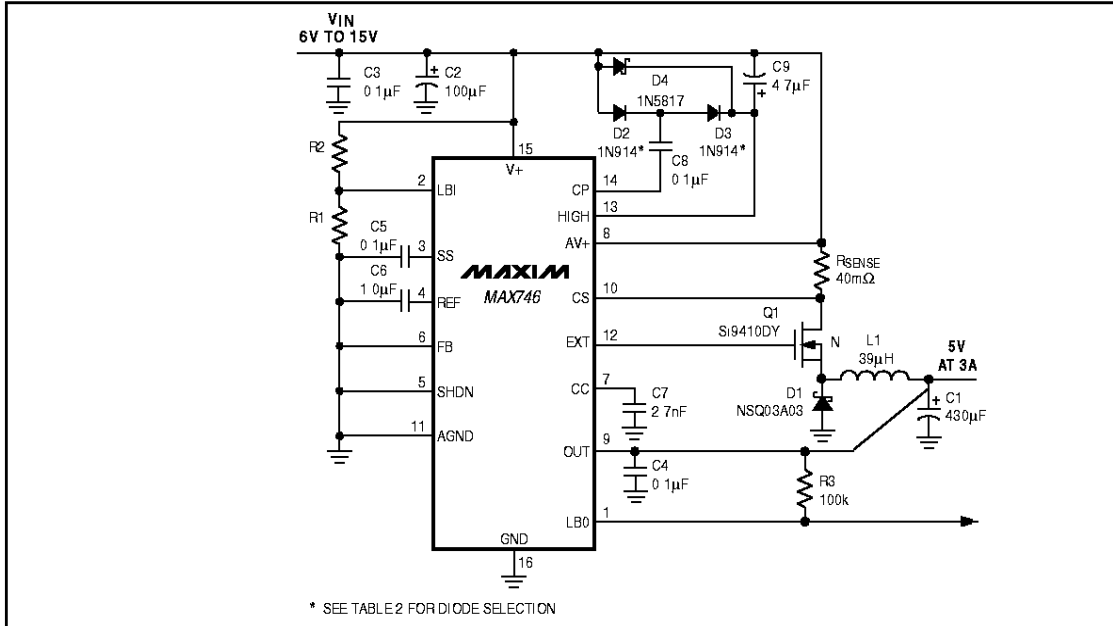

Figure 1a. 5V Standard Application Circuit (15W)

Discontinuous-/Continuous-Conduction Modes

The MAX746 is designed to operate in continuous-conduction mode (CCM) but can also operate in discontinuous-conduction mode (DCM), making it ideal for variable-load applications. In DCM, the current starts at zero and returns to zero on each cycle. In CCM, the inductor current never returns to zero; it consists of a small AC component superimposed on a DC offset. This results in higher current capability because the AC component in the inductor current waveform is small. It also results in lower output noise, since the inductor does not exhibit the ringing that would occur if the current reached zero (see inductor waveforms in the *Typical Operating Characteristics*). To transfer equal amounts of energy to the load in one cycle, the peak current level for the discontinuous waveform must be much larger than the peak current for the continuous waveform.

Slope Compensation

Slope compensation stabilizes the inner current-feedback loop by adding a ramp signal to the current-sense amplifier output. Ideal slope compensation can be achieved by adding a linear ramp, with the same slope as the declining inductor current, to the rising inductor current-sense voltage.

Under these conditions, the inductor must be scaled to the current-sense resistor value.

Overcompensation adds a pole to the outer voltage feedback-loop response, degrading loop stability. This may cause voltage-mode pulse-frequency-modulation instead of PWM operation. Undercompensation results in inner current feedback-loop instability, and may cause the inductor current to staircase. Ideal matching between the sense resistor and inductor is not required; it can differ by $\pm 30\%$ or more.

Oscillator and EXT Control

The oscillator frequency is nominally 100kHz, and the duty cycle varies from 5% to 96%, depending on the input/output voltage ratio. EXT, which provides the gate drive for the external logic-level N-FET, is switched between HIGH and GND at the switching frequency. EXT is controlled by a unique two-comparator control scheme consisting of a PWM comparator and an idle-mode comparator (Figure 2). The PWM comparator determines the cycle-by-cycle peak current with heavy loads, and the idle-mode comparator sets the light-load peak current. As V_{OUT} begins to drop, EXT goes high and remains high until both comparators trip. With heavy loads, the idle-mode comparator trips first and the PWM control comparator determines the EXT on-time;

High-Efficiency, PWM, Step-Down, N-Channel DC-DC Controller

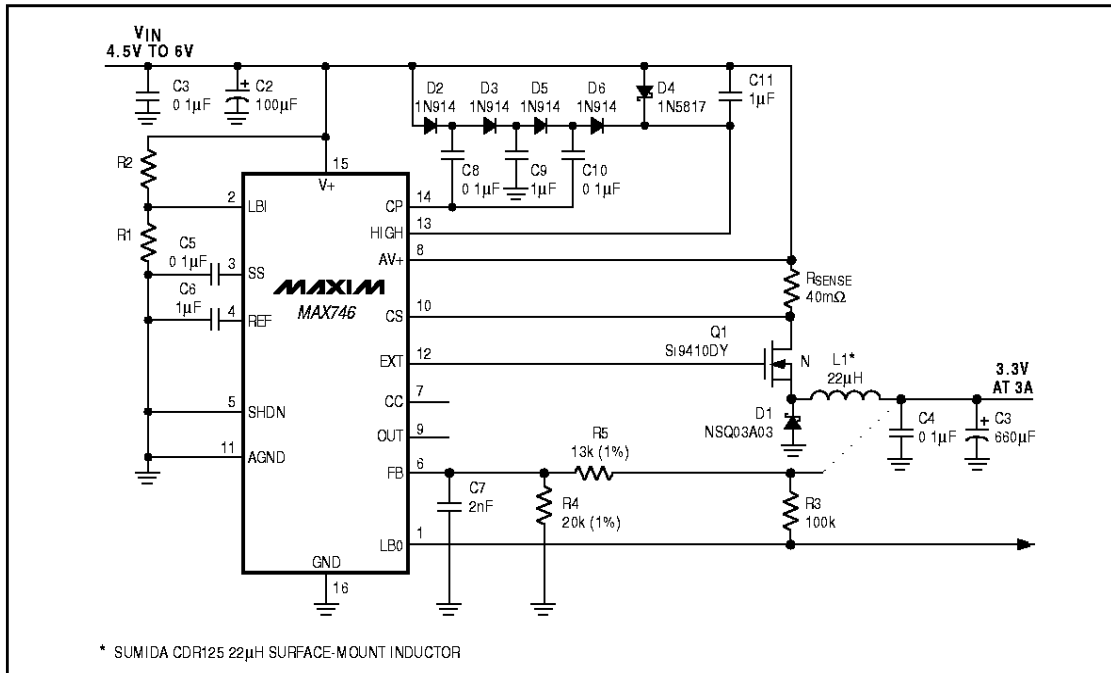

Figure 1b. 3.3V Standard Application Circuit (9.9W)

with light loads, the PWM comparator trips quickly and the idle-mode comparator sets the EXT on-time.

Traditional PWM converters continue to switch on every cycle, even when the inductor current is discontinuous due to smaller loads, decreasing light-load efficiency. In contrast, the MAX746's idle-mode comparator increases the switch on-time, allowing more energy to be transferred per cycle. Since fewer cycles are required, the switching frequency is reduced, resulting in minimal switching losses and increased efficiency.

The light-load output noise spectrum widens due to the variable switching frequency in idle-mode, but output ripple remains low. Using the Typical Operating Circuit, with a 9V input and a 125mA load current, output ripple is less than 40mV.

Charge Pump

The MAX746 contains all the control circuitry required to provide a regulated charge-pump voltage 5V above V_+ for high-side driving N-channel logic FETs. The charge pump operates with a nominal 50kHz fre-

quency. When the voltage at HIGH exceeds AV_+ by 5V, the charge-pump oscillator is inhibited (Figure 2). When the voltage at HIGH is less than 4.3V below V_+ , undervoltage lockout occurs. Use the voltage tripler (Figure 3b) when $V_+ \leq 6V$; otherwise, use the voltage doubler (Figure 3a).

Soft-Start and Current Limiting

The MAX746 draws its highest current at power-up. If the power source to the MAX746 cannot provide this initial elevated current, the circuit may not function correctly. For example, after prolonged use the increased series resistance of a battery may prevent it from providing adequate initial surge currents when the MAX746 is brought out of shutdown. Using soft-start (SS) minimizes the possibility of overloading the incoming supply at power-up by gradually increasing the peak current limit. Connect an external capacitor from SS to AGND to reduce the initial peak currents drawn from the supply.

High-Efficiency, PWM, Step-Down, N-Channel DC-DC Controller

MAX746

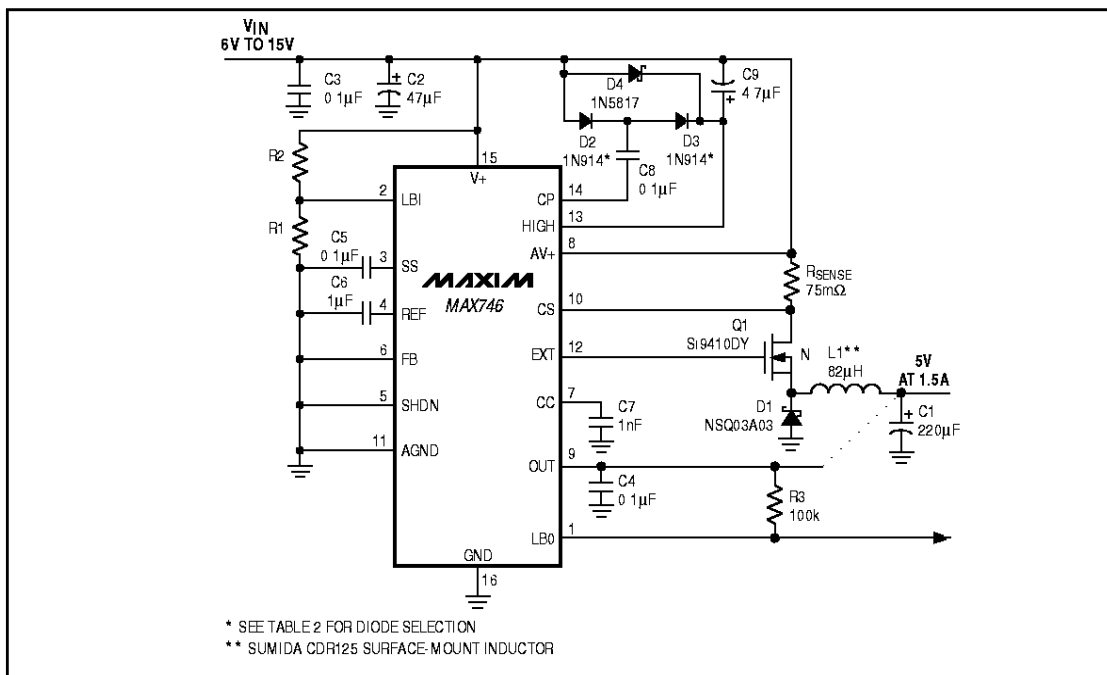

Figure 1c. 5V Standard Application Circuit (7.5W)

The steady-state SS pin voltage is typically 3.8V. On power-up, SS sources 1µA until its voltage reaches 3.8V. The current-limit comparator inhibits EXT switching until the SS voltage reaches 1.8V. The peak current limit is set by:

$$I_{PK} = \frac{V_{LIMIT}}{R_{SENSE}} = \frac{150\text{mV (typ)}}{R_{SENSE}}$$

where V_{LIMIT} is the differential voltage across the current-sense amplifier inputs. Figure 4 shows how the SS peak current limit increases as the voltage on SS rises for two R_{SENSE} values.

Undervoltage Lockout

Undervoltage lockout inhibits operation of EXT until the charge pump is capable of generating a voltage greater than 4.3V above the supply voltage (Figure 2). When the undervoltage-lockout comparator detects an undervoltage condition, the switching action at EXT is halted.

Shutdown Mode

When SHDN is high, the MAX746 is shut down. In this mode, the internal biasing circuitry (including EXT) is turned off, V_{OUT} drops to 0V, and the supply current drops to 1.4µA (20µA max). This excludes external component leakage, which may add several microamps to the shutdown supply current for the entire circuit. SHDN is a logic input. Connect SHDN to GND for normal operation.

Low-Battery Detector

The MAX746 provides a low-battery comparator that compares the voltage on LBI to the reference voltage. LBO, an open-drain output, goes low when the LBI voltage is below V_{REF} . Use a resistor-divider network, as shown in the Input Voltage Monitor Circuit (Figure 5), to set the trip voltage (V_{TRIP}) at the desired level. In this circuit, LBO goes low when $V_+ \leq V_{TRIP}$. LBO is high impedance in shutdown mode.

High-Efficiency, PWM, Step-Down, N-Channel DC-DC Controller

MAX746

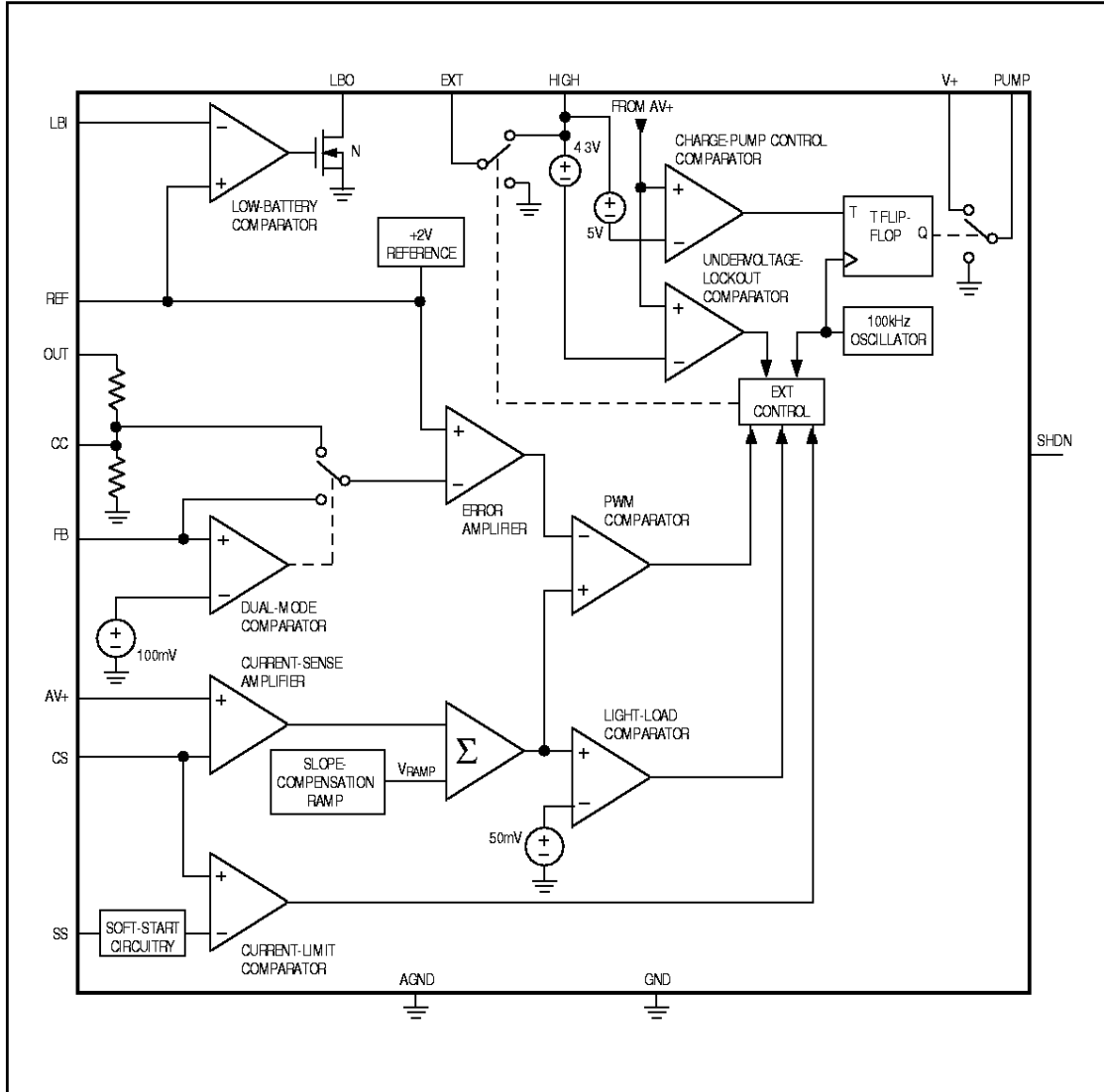

Figure 2. Block Diagram

High-Efficiency, PWM, Step-Down, N-Channel DC-DC Controller

MAX746

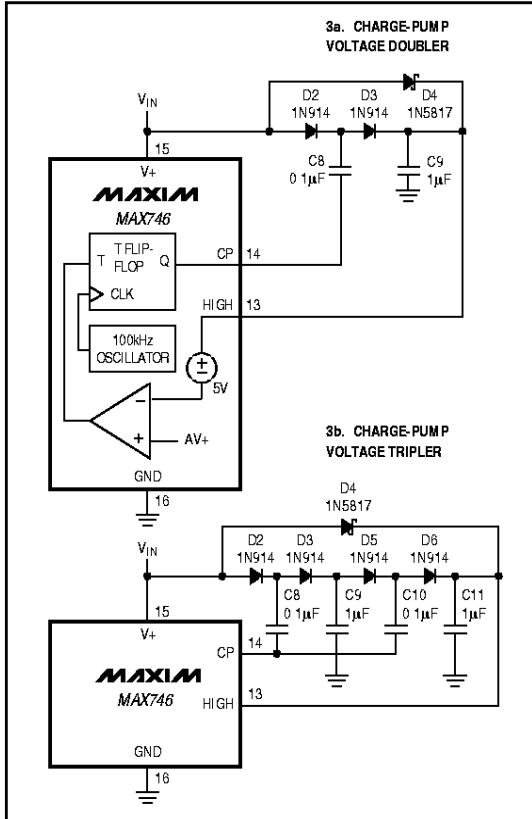

Figure 3. Charge-Pump Configurations

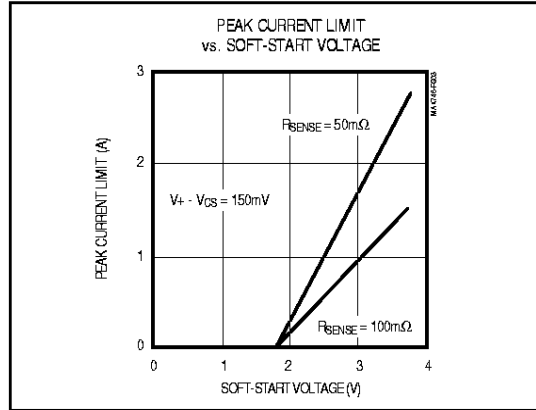

Figure 4. Peak Current Limit vs. Soft-Start Voltage

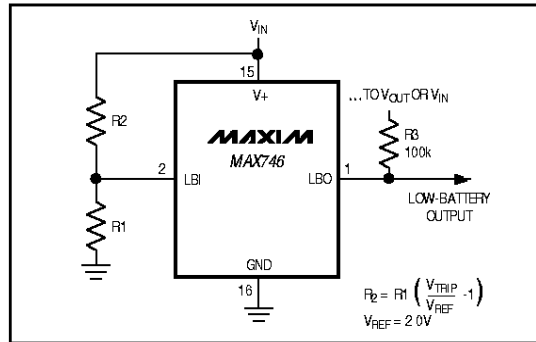

Figure 5. Input Voltage Monitor Circuit

Design Procedure

Setting the Output Voltage

The MAX746's dual-mode output voltage can be set to 5V by grounding FB, or it can be adjusted from 2V to 14V using external resistors R4 and R5 configured as shown in Figure 6. Select feedback resistor R4 in the 10kΩ to 60kΩ range. R5 is given by:

$$R5 = (R4) \left(\frac{V_{OUT}}{2V} - 1 \right)$$

The MAX746 is designed to use either internal or external feedback mode, but should not be toggled between

the two modes while operating. If two different output voltages are required, use external feedback mode with a resistor network similar to the 3.3V/5V adjustable output circuit shown in Figure 7.

Selecting RSENSE

To select the sense-resistor value (RSENSE), first approximate the peak current assuming IPK is (1.1) (ILOAD), where ILOAD is the maximum load current. Once all component values have been determined, the actual peak current is given by:

$$I_{PK} = I_{LOAD} + \left(\frac{V_{OUT}}{(2L)(f_{OSC})} \right) \left(1 - \frac{V_{OUT}}{V_{IN}} \right)$$

High-Efficiency, PWM, Step-Down, N-Channel DC-DC Controller

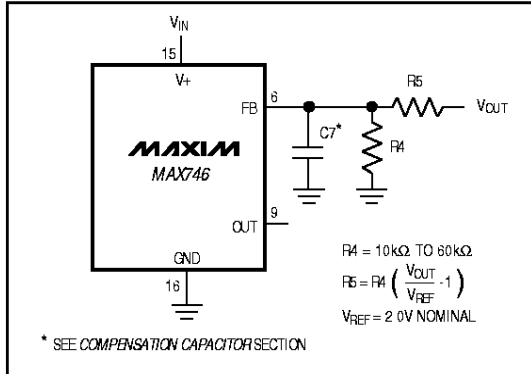

Figure 6. Adjustable Output Circuit

Next, determine the value of R_{SENSE} such that:

$$R_{SENSE} = \frac{V_{LIMIT(min)}}{I_{PK}} = \frac{125mV}{I_{PK}}$$

For example, to obtain 5V at 3A, $I_{PK} = 3.3A$ and $R_{SENSE} = 125mV/3.3A = 38m\Omega$.

The sense resistor should have a power rating greater than $(I_{PK}^2) (R_{SENSE})$ with an adequate safety margin. With a 3A load current, $I_{PK} = 3.3A$ and $R_{SENSE} = 38m\Omega$. The power dissipated by the resistor (assuming an 80% duty cycle) is 331mW. Metal-film resistors are recommended. Do not use wire-wound resistors because their inductance will adversely affect circuit operation.

The duty cycle (for continuous conduction) is determined from the following equation:

$$\text{Duty Cycle (\%)} = \frac{V_{OUT} + V_{DIODE}}{V_+ - V_{SW} + V_{DIODE}} \times 100\%$$

where V_{SW} is the voltage drop across the external N-FET and sense resistor. V_{SW} can be approximated as $[I_{LOAD} \times (r_{DS(ON)} + R_{SENSE})]$.

Inductor Selection

Once the sense-resistor value is determined, calculate the inductor value (L) using the following equation. The correct inductor value ensures proper slope compensation. Continuing from the equations above:

$$\begin{aligned} L &= \frac{(R_{SENSE})(V_{OUT})}{(V_{RAMP(max)})(f_{OSC})} \\ &= \frac{(38m\Omega)(5V)}{(50mV)(100kHz)} = 38\mu H \end{aligned}$$

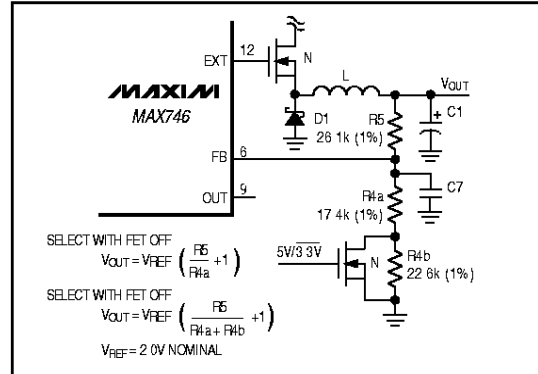

Figure 7. 3.3V/5V Adjustable Output Circuit

where $V_{RAMP(max)}$ is the 50mV peak value of the slope-compensation linear ramp signal.

Although 38 μ H is the calculated value, the component used may have a tolerance of $\pm 30\%$ or more.

Inductors with molypermalloy powder (MPP), Kool M μ , or ferrite are recommended. Inexpensive iron-powder core inductors are not suitable, due to their increased core losses, especially at switching frequencies in the 100kHz range. MPP and Kool M μ cores have low permeability, allowing larger currents.

For highest efficiency, use a coil with low DC resistance. To minimize radiated noise, use a toroid, a pot core, or a shielded coil.

It is customary to select an inductor with a saturation rating that exceeds the peak current set by R_{SENSE} , but inductors are often specified very conservatively. If the inductor's core losses do not cause excessive temperature rise (inductor wire insulation is usually rated for +125°C) and the associated efficiency losses are minimal, inductors with lower current ratings are acceptable.

In the 3.3V Standard Application Circuit (Figure 1b), the inductor selected has a 2.2A current rating even though the peak current is 3.3A. This inductor was selected for two reasons: it is the highest-rated readily available surface-mount inductor of its size, and lab tests have verified that the core-loss increase is minimal. With a 3A load current, the inductor current does not begin showing significant losses due to saturation until the supply voltage increases to 10V (the maximum supply for this circuit is 6V).

High-Efficiency, PWM, Step-Down, N-Channel DC-DC Controller

External Logic-Level N-FET Selection

To ensure the external N-FET is turned on hard, use logic-level or low-threshold N-FETs. Three important parameters to note when selecting the N-FET are the total gate charge (Q_g), on resistance ($r_{DS(ON)}$), and reverse transfer capacitance ($CRSS$).

Q_g includes all capacitances associated with charging the gate. Use the typical Q_g value for best results; the maximum value is usually grossly overspecified, since it is a guaranteed limit and not the measured value. The typical total gate charge should be 50nC or less; with larger numbers, EXT may not be able to adequately drive the gate. EXT sink/source capability (I_{EXT}) is typically 210mA.

The two most significant losses contributing to the N-FET's power dissipation are I^2R losses and switching losses. CCM power dissipation (P_D), is approximated by:

$$P_D = (\text{Duty Cycle}) (I_{PK}^2) (r_{DS(ON)}) + \frac{(V_{+2}) (CRSS) (I_{PK}) (f_{OSC})}{(I_{EXT})}$$

where the duty cycle is approximately V_{OUT}/V_{+} , $f_{OSC} = 100\text{kHz}$, and $r_{DS(ON)}$ and $CRSS$ are given in the data sheet of the chosen N-FET. In the equation, $r_{DS(ON)}$ is assumed constant, but is actually a function of temperature. The equation given does not account for losses incurred by charging and discharging the gate capacitance, because that energy is dissipated by the gate-drive circuitry, not the N-FET.

The Standard Application Circuits (Figure 1) use an 8-pin, Si9410DY, surface-mount N-FET that has 0.05Ω on resistance with a 4.5V V_{GS} . Optimum efficiency is obtained when the voltage at the source swings between the supply rails (within a few hundred millivolts).

Diode Selection

The MAX746's high switching frequency demands a high-speed rectifier. Schottky diodes are recommended. Ensure that the Schottky diode average current rating exceeds the maximum load current.

Capacitor Selection

Output Filter Capacitor

The output filter capacitor C_1 should have a low effective series resistance (ESR), and its capacitance should remain fairly constant over temperature. This is especially true when in CCM, since the output filter capacitor and the load form the dominant pole that stabilizes the voltage loop.

To ensure stability, the minimum capacitance and maximum ESR values are:

$$C_{1(\text{min})} > \frac{(5) (V_{REF})}{(2\pi) (GBW) (V_{OUT}) (R_{SENSE})}$$

and,

$$ESR_{C1} < \frac{(V_{OUT}) (R_{SENSE})}{(V_{REF})}$$

where GBW = the loop gain-bandwidth product, 15kHz.

Sprague 595D surface-mount solid tantalum capacitors and Sanyo OS-CON through-hole capacitors are recommended due to their extremely low ESR. OS-CON capacitors are particularly useful at low temperatures. For best results when using other capacitors, increase the output filter capacitor's size or use capacitors in parallel to reduce the ESR.

Bypass OUT with a $0.1\mu\text{F}$ (C_4) capacitor to GND when using a fixed 5V output (Figures 1a and 1c). With adjustable-output operation, place C_4 between the output voltage and AGND as close to the IC as possible (Figure 1b).

The circuit load-step response is improved by using a larger output filter capacitor or by placing a low-cost bulk capacitor in parallel with the required low-ESR output filter capacitor. The output voltage sag under a load step (I_{STEP}) is approximated by:

$$V_{SAG} = \frac{(I_{STEP}^2) (L)}{(2) (C_1) (V_{IN(\text{MIN})}) (D_{MAX} - V_{OUT})}$$

where D_{MAX} is the maximum duty cycle (91% worst case). The equation assumes an input/output voltage differential of 2V or more. Table 1 gives measured values of output voltage sag with a 30mA to 3A load step for various input voltages and output filter capacitors. Refer also to the *AC Stability with Low Input/Output Differentials* section.

Input Bypass Capacitor

The input bypass capacitor C_2 reduces peak currents drawn from the voltage source, and also reduces the amount of noise at the voltage source caused by the MAX746's fast switching action (this is especially important when other circuitry is operated from the same source). The input capacitor ripple current rating must exceed the RMS input ripple current.

$$I_{RMS} = \text{RMS AC input current} \\ = I_{LOAD} \left(\frac{\sqrt{(V_{OUT}) (V_{IN} - V_{OUT})}}{V_{IN}} \right)$$

High-Efficiency, PWM, Step-Down, N-Channel DC-DC Controller

Table 1. Measured Output Voltage Sag with 30mA to 3A Load Step*

OUTPUT FILTER CAPACITOR C1 (μF)	OUTPUT VOLTAGE SAG (mV) FOR VARIOUS INPUT VOLTAGES				
	V _{IN} =6V	V _{IN} =6.5V	V _{IN} =7V	V _{IN} =9V	V _{IN} =10V
440	400	250	210	140	90
660	260	190	160	70	50
880	200	100	90	40	25

*Circuit of Figure 1a.

For load currents up to 3A, 100μF (C2) in parallel with 0.1μF (C3) is adequate. Smaller bypass capacitors may also be acceptable for lighter loads. The input voltage source impedance determines the size of the capacitor required at the V₊ input. As with the output filter capacitor, a low-ESR capacitor (Sanyo OS-CON, Sprague 595D or equivalent) is recommended for input bypassing.

Charge-Pump Capacitors

Figure 3a shows the charge-pump doubler circuit configured with a 0.1μF charge-pump capacitor C8 and a 1.0μF reservoir capacitor C9. The ratio of the capacitors, along with the input voltage, determines the amount of ripple on HIGH. If the input supply range exceeds 12V, increase C9 to 4.7μF to reduce the charge-pump ripple. C9 should be 10μF for less. Figure 3b shows the charge-pump tripler circuit.

Refer to Table 2 to determine the proper charge-pump configuration (which is based on the minimum expected supply voltage at V₊).

Some interaction occurs between the switch oscillator and the charge-pump oscillator. This interaction modulates the inductor-current waveform, but has negligible impact on the output.

Soft-Start and Reference Capacitors

Soft-start provides a ramp to the full current limit. A typical value for the soft-start capacitor (C5) is 0.1μF, which provides a 380ms soft-start time. Use values in the 0.001μF to 1μF range. The nominal time for C5 to reach its steady-state value is given by:

$$t_{SS} (\text{sec}) = (C5) (3.8 \times 10^6)$$

Note that t_{SS} does NOT equal the time it takes for the MAX746 to power-up, although it does affect the start-up time. The start-up time is also a function of the input

Table 2. Charge-Pump Configuration

V ₊	CHARGE-PUMP CONFIGURATION
V ₊ ≤ 6V	Voltage tripler with 1N914 diodes for D2, D3, D5, and D6
6V < V ₊ < 6.5V*	Voltage doubler with 1N5817 Schottky diodes for D2 and D3
V ₊ ≥ 6.5V*	Voltage doubler with 1N914 diodes for D2 and D3

* When using the voltage-doubler circuit over the military temperature range, increase the 6.5V limit to 7V.

voltage and load current. With a 3A load current, a 10V input voltage, and a 0.1μF soft-start capacitor, it typically takes 240ms for the MAX746 to power up. A 0.47μF soft-start capacitor increases the start-up time to approximately 2.3sec.

Bypass REF with a 1μF capacitor (C6).

Compensation Capacitor

With a fixed 5V output, connect a compensation capacitor (C7) between CC and AGND to optimize transient response. Appropriate compensation is determined by the size and ESR of the output filter capacitor (C1), and by the load current.

In the standard 5V application circuit, 2.7nF is appropriate for load currents up to 3A; for lighter loads, C7's value can be reduced. If 2.7nF does not compensate adequately, use the following equations to determine C7.

For fixed 5V-output operation:

$$C7 = \frac{(C1) (ESRC1)}{12k\Omega}$$

For adjustable-output operation, FB becomes the compensation input pin, and CC and OUT are left unconnected. Connect C7 between FB and GND in parallel with R4 (Figure 6). C7 is determined by:

$$C7 = \frac{(2) (C1) (ESRC1)}{R4 \parallel R5}$$

For example, with a fixed 5V output with C1 = 470μF and an $ESRC1$ of 0.04Ω (at a frequency of 100kHz):

$$C7 = \frac{(C1) (ESRC1)}{12k\Omega} = 1560\text{pF}$$

High-Efficiency, PWM, Step-Down, N-Channel DC-DC Controller

MAX746

Increasing C7 by up to 50% enhances outer-loop stability by adding stability to the inductor current waveform. But increasing C7 too much causes FB's response time to decrease (due to the larger RC time constant caused by the feedback resistors and the compensation capacitor), which reduces load-transient stability.

Setting the Low-Battery Detector Voltage

Select R1 between 10kΩ and 1MΩ. Determine R2 using the following equation:

$$R2 = R1 \left(\frac{V_{TRIP} - V_{REF}}{V_{REF}} \right)$$

where VREF is typically 2.0V. Connect a pull-up resistor (e.g., 100kΩ) between LBO and VOUT (Figure 5).

Using a Second Supply in Place of the Charge Pump

If a secondary power supply (a minimum of 5V above the main supply) is available, it can be substituted for the charge-pump high-side supply. In this case, bypass HIGH with a 1μF capacitor and leave CP unconnected. Since this secondary supply voltage is applied to the gate, VGS must not exceed the gate-source breakdown voltage of the external N-FET. Also, the voltage at HIGH must not exceed 20V. **If a secondary supply is used, the shutdown function cannot be used because HIGH is internally tied to V+ in shutdown mode.** In this case, SHDN must be tied low. With the main supply off and HIGH at 12V, HIGH will typically sink 130μA.

Layout Considerations

Because high current levels and fast switching waveforms radiate noise, proper PC board layout is essential. Use a ground plane, and minimize ground noise by connecting GND, the anode of the steering Schottky diode, the input bypass-capacitor ground lead, and the output filter capacitor ground lead to a single point (star ground configuration). Also minimize lead lengths to reduce stray capacitance, trace resistance, and radiated noise. Place bypass capacitor C3 as close to V+ and GND as possible.

AV+ and CS are the inputs to the differential-input current-sense amplifier. Use a Kelvin connection across the sense resistor, as shown in Figure 8. Although AV+ also functions as the supply voltage for sensitive analog circuitry, a separate AV+ bypass capacitor should not be used. By not using a capaci-

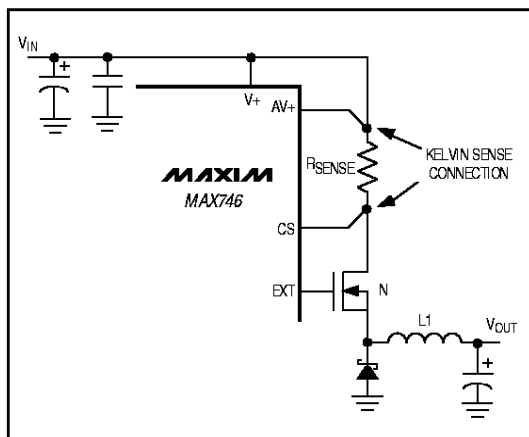

Figure 8. Kelvin Connection for Current-Sense Amplifier

tor, any noise at the CS input will also appear at the AV+ input, and will be interpreted by the current-sense amplifier as a common-mode signal. A separate AV+ capacitor causes the noise to appear on only one input, and this differential noise will be amplified, adversely affecting circuit operation.

Additional Notes

When probing the MAX746 circuit, avoid shorting V+ to GND (the two pins are adjacent) as this may cause the IC to malfunction because of large ground currents. Because of its fast switching and high drive-capability requirements, EXT is a low-impedance point that is not short-circuit protected. Therefore, do not short EXT to any node (including AGND and V+, which are adjacent to EXT).

Similarly, CC (or FB in adjustable-output operation) is a sensitive input that should not be shorted to any node. Avoid shorting CC when probing the circuit, as this may damage the device.

The MAX746 may continue to operate with AV+ disconnected, but erratic switching waveforms will appear at EXT.

Switching Waveforms

There is a region between CCM and DCM where the inductor current operates in both modes, as shown in the Idle-Mode Moderate Current EXT waveform in the *Typical Operating Characteristics*. As the output voltage varies, it is fed back into CC and the duty cycle adjusts to compensate for this change. The switch is considered off when VEXT is less than

High-Efficiency, PWM, Step-Down, N-Channel DC-DC Controller

or equal to the N-FET's V_{GS} threshold voltage. Once the switch is off, the voltage at EXT is pulled to GND and the N-FET source voltage is a Schottky diode drop below GND. However, this is not always the case in the "in-between" mode, due to the changing duty cycle inherent with DCM. When the device is at maximum duty cycle, EXT turns off at V_{GS} , but the switch sometimes turns on again after the minimum off-time before EXT can be pulled to GND. This results in short spikes, which can be seen on the EXT waveform in the *Typical Operating Characteristics*.

AC Stability with Low Input/Output Differentials
At low input/output differentials, the inductor current cannot slew quickly enough to respond to load changes, so the output filter capacitor must hold up the voltage as the load transient is applied. In Figure 1a's circuit, for $V_+ = 6V$, increase the output filter capacitor to $900\mu F$ (Sprague 595D low-ESR capacitors) to obtain a transient response less than $250mV$ with a load step from $0.1A$ to $3A$. As V_+ increases, the inductor current slews faster, so the size of the output filter capacitor can be reduced (see Table 1).

Table 3. Component Suppliers

SUPPLIER	PHONE	FAX
INDUCTORS		
Coiltronics	(305) 781-8900	(305) 782-4163
Gowanda	(716) 532-2234	(716) 532-2702
Sumida USA	(708) 956-0666	(708) 956-0702
Sumida Japan	81-3-3607-511	81-3-3607-5428
CAPACITORS		
Kemet	(803) 963-6300	(803) 963-6322
Matsuo	(714) 969-2491	(714) 960-6492
Nichicon	(708) 843-7500	(708) 843-2798
Sprague	(603) 224-1961	(603) 224-1430
Sanyo USA	(619) 661-6322	
Sanyo Japan	81-3-3837-6242	
United Chemi-Con	(714) 255-9500	(714) 255-9400
DIODES		
Motorola	(800) 521-6274	
Nihon USA	(805) 867-2555	(805) 867-2698
Nihon Japan	81-3-3494-7411	81-3-3494-7414
POWER TRANSISTORS		
Harris	(407) 724-3739	(407) 724-3937
International Rectifier	(213) 772-2000	(213) 772-9028
Siliconix	(408) 988-8000	(408) 727-5414
RESISTORS		
IRC	(512) 992-7900	(512) 992-3377

Chip Topography

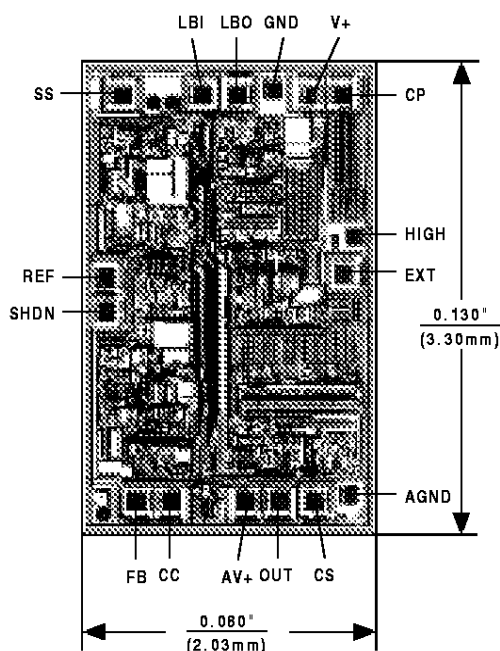

TRANSISTOR COUNT: 508;
SUBSTRATE CONNECTED TO HIGH.

Maxim cannot assume responsibility for use of any circuitry other than circuitry entirely embodied in a Maxim product. No circuit patent licenses are implied. Maxim reserves the right to change the circuitry and specifications without notice at any time.

16 _____ Maxim Integrated Products, 120 San Gabriel Drive, Sunnyvale, CA 94086 (408) 737-7600