

THIS IS ISSUED IN STRICT CONFIDENCE THAT IT IS NOT USED AS A BASIS FOR MANUFACTURE OR SALE AND THAT IT IS NOT COPIED, REPRINTED OR DISCLOSED TO A THIRD PARTY EITHER WHOLLY OR IN PART WITHOUT THE PRIOR WRITTEN CONSENT OF CAL TEST ELECTRONICS, INC.

REVISIONS			
REV.	DESCRIPTIONS	DATE	APPROVED
—	CLASS A RELEASED	7/12/99	

- ADAPTER, 4mm BANANA PLUG WITH 4mm BANANA JACK.
- SPECIFICATIONS:  
 INSULATOR: POLYACETAL  
 PLUG BODY: BRASS, NICKEL PLATED  
 SPRING BODY: BERYLLIUM COPPER, NICKEL PLATED
- RATING:  
 CURRENT: 10A MAX.  
 RESISTANCE: <0.8mΩ.  
 TEMPERATURE: -20° C TO +80° C.

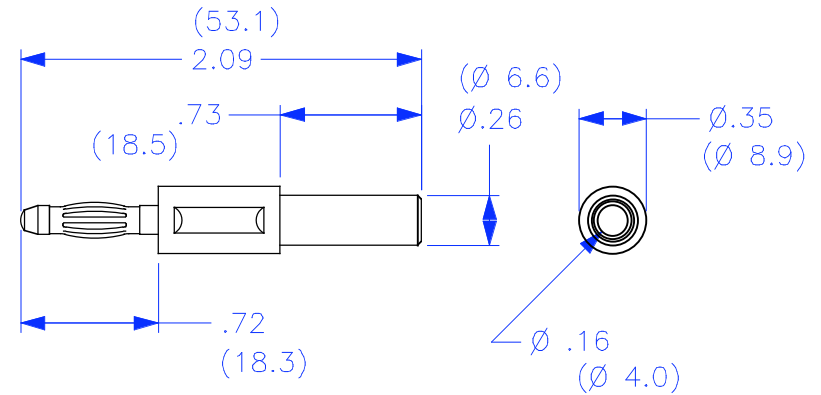

**PART NUMBER**

**CT2473-#**

- COLOR:
- 0 — BLACK
  - 2 — RED
  - 4 — YELLOW
  - 5 — GREEN
  - 6 — BLUE
  - 9 — WHITE

THIRD ANGLE PROJECTION		UNLESS OTHERWISE SPECIFIED DIMENSIONS ARE IN INCHES TOLERANCES ARE: FRACTIONS DECIMALS ± 1/32 .XX ± .02 .XXX ± .005 DO NOT SCALE DRAWING	CONTRACT NO.		<b>Cal Test Electronics</b> 22820 Savi Ranch Parkway Yorba Linda, CA 92887-4610			
			APPROVALS	DATE	TITLE			
NEXT ASSY		MATERIAL	DRAWN	43F45	4mm BANANA PLUG ADAPTER w/4mm JACK			
USED ON		FINISH	CHECKED	7/12/99	SIZE	CAGE CODE	DWG. NO.	REV.
APPLICATION			ENGR.		A	43F45	P247300	—
			DESIGN ACTIVITY		SCALE	1:1	SHEET	1 OF 1