

# 8K × 8 Dual-Port Static RAM with SEM, INT, BUSY

## Features

- True dual-ported memory cells that enable simultaneous reads of the same memory location
- 8K × 8 organization (CY7C144E)
- 0.35-micron CMOS for optimum speed and power
- High-speed access: 15 ns
- Low operating power:  $I_{CC} = 180$  mA (typical), standby  $ISB3 = 0.05$  mA (typical)
- Fully asynchronous operation
- Automatic power-down
- TTL compatible
- Master / slave select pin enables bus width expansion to 16-bits or more
- Busy arbitration scheme provided
- Semaphores included to permit software handshaking between ports
- $\overline{INT}$  flag for port-to-port communication
- Available in 68-pin PLCC and 64-pin TQFP
- Pb-free packages available

## Functional Description

The CY7C144E is a high speed CMOS 8K × 8 dual port static RAM. Various arbitration schemes are included on the CY7C144E to handle situations when multiple processors access the same piece of data. Two ports are provided permitting independent, asynchronous access for reads and writes to any location in memory. The CY7C144E can be used as a standalone 64-Kbit dual-port static RAM or multiple devices can be combined in order to function as a 16-bit or wider master/slave dual-port static RAM. An  $M/\overline{S}$  pin is provided for implementing 16-bit or wider memory applications without the need for separate master and slave devices or additional discrete logic. Application areas include interprocessor/multiprocessor designs, communications status buffering, and dual-port video / graphics memory.

Each port has independent control pins: chip enable ( $\overline{CE}$ ), read or write enable ( $R/\overline{W}$ ), and output enable ( $\overline{OE}$ ). Two flags,  $\overline{BUSY}$  and  $\overline{INT}$ , are provided on each port.  $\overline{BUSY}$  signals that the port is trying to access the same location currently being accessed by the other port. The interrupt flag ( $\overline{INT}$ ) permits communication between ports or systems by means of a mail box. The semaphores are used to pass a flag, or token, from one port to the other to indicate that a shared resource is in use. The semaphore logic is comprised of eight shared latches. Only one side can control the latch (semaphore) at any time. Control of a semaphore indicates that a shared resource is in use. An automatic power-down feature is controlled independently on each port by a chip enable ( $\overline{CE}$ ) pin or SEM pin.

For a complete list of related documentation, click [here](#).

## Logic Block Diagram

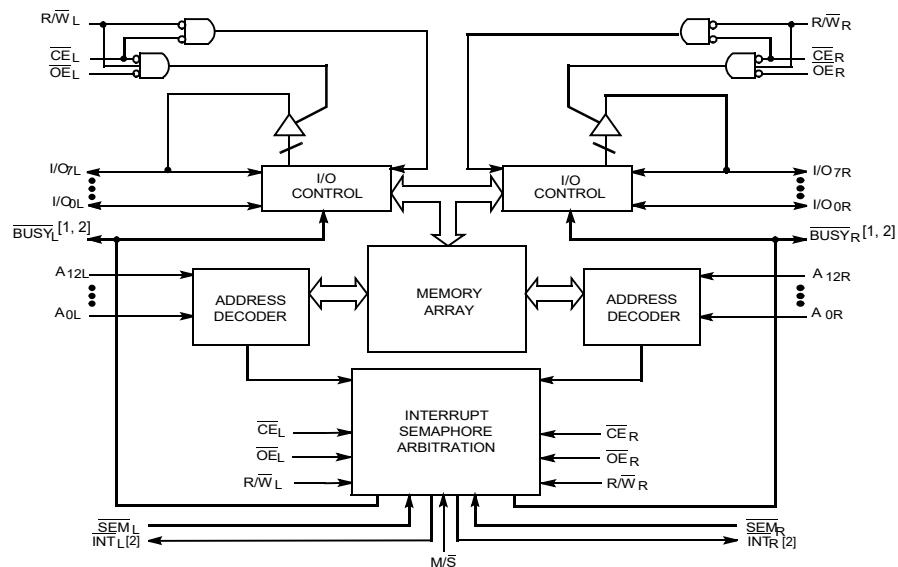

### Notes

1.  $\overline{BUSY}$  is an output in master mode and an input in slave mode.
2. Interrupt: push-pull output and requires no pull-up resistor.

## Contents

|  |          |  |           |
|--|----------|--|-----------|
| <b>Selection Guide</b> .....             | <b>3</b> | <b>Switching Characteristics</b> .....               | <b>9</b>  |
| <b>Pin Configuration</b> .....           | <b>3</b> | <b>Switching Waveforms</b> .....                     | <b>11</b> |
| <b>Pin Definitions</b> .....             | <b>4</b> | <b>Typical DC and AC Characteristics</b> .....       | <b>17</b> |
| <b>Architecture</b> .....                | <b>4</b> | <b>Ordering Information</b> .....                    | <b>18</b> |
| <b>Functional Overview</b> .....         | <b>5</b> | Ordering Code Definitions .....                      | 18        |
| Write Operation .....                    | 5        | <b>Package Diagrams</b> .....                        | <b>19</b> |
| Read Operation .....                     | 5        | <b>Acronyms</b> .....                                | <b>21</b> |
| Interrupts .....                         | 5        | <b>Document Conventions</b> .....                    | <b>21</b> |
| Busy .....                               | 5        | Units of Measure .....                               | 21        |
| Master/Slave .....                       | 6        | <b>Document History Page</b> .....                   | <b>22</b> |
| Semaphore Operation .....                | 6        | <b>Sales, Solutions, and Legal Information</b> ..... | <b>23</b> |
| <b>Maximum Ratings</b> .....             | <b>7</b> | Worldwide Sales and Design Support .....             | 23        |
| <b>Operating Range</b> .....             | <b>7</b> | Products .....                                       | 23        |
| <b>Electrical Characteristics</b> .....  | <b>7</b> | PSoC® Solutions .....                                | 23        |
| <b>Capacitance</b> .....                 | <b>8</b> | Cypress Developer Community .....                    | 23        |
| <b>AC Test Loads and Waveforms</b> ..... | <b>8</b> | Technical Support .....                              | 23        |

### Selection Guide

| Description  | 7C144E-15 | 7C144E-25 | 7C144E-55 | Unit |
|--|-----------|-----------|-----------|------|
| Maximum access time                                      | 15        | 25        | 55        | ns   |
| Typical operating current                                | 190       | 180       | 180       | mA   |
| Typical Standby Current for ISB1 (both ports TTL level)  | 50        | 45        | 45        | mA   |
| Typical Standby Current for ISB3 (both ports CMOS level) | 0.05      | 0.05      | 0.05      | mA   |

### Pin Configuration

Figure 1. 68-pin PLCC pinout (Top View)

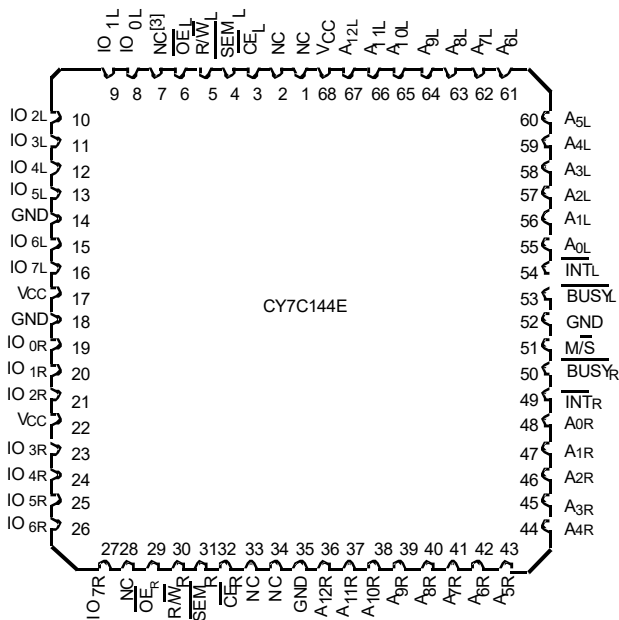
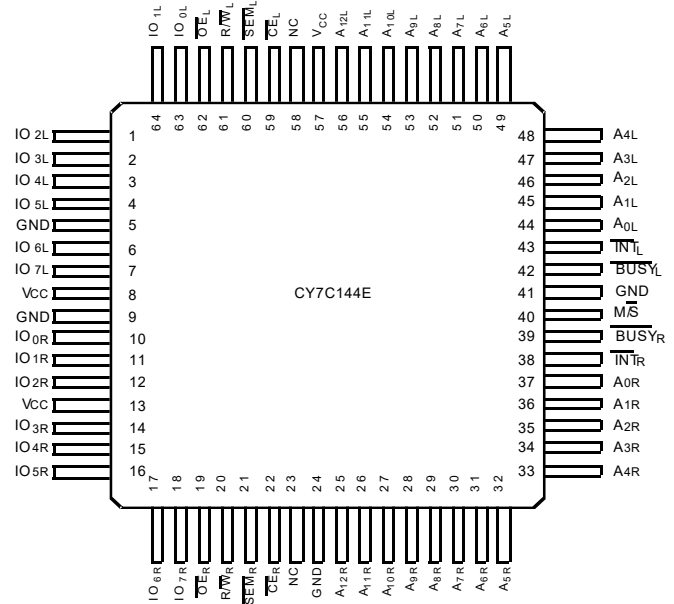

Figure 2. 64-pin TQFP pinout (Top View)



**Note**

3. This pin is NC.

## Pin Definitions

| Left Port            | Right Port           | Description  |
|----------------------|----------------------|--|
| I/O <sub>0L-7L</sub> | I/O <sub>0R-7R</sub> | Data bus I/O   |
| A <sub>0L-12L</sub>  | A <sub>0R-12R</sub>  | Address lines  |
| $\overline{CE}_L$    | $\overline{CE}_R$    | Chip enable  |
| $\overline{OE}_L$    | $\overline{OE}_R$    | Output enable  |
| $\overline{R/W}_L$   | $\overline{R/W}_R$   | Read / write enable  |
| $\overline{SEM}_L$   | $\overline{SEM}_R$   | Semaphore enable. When asserted LOW, allows access to eight semaphores. The three least significant bits of the address lines will determine which semaphore to write or read. The I/O <sub>0</sub> pin is used when writing to a semaphore. Semaphores are requested by writing a 0 into the respective location. |
| $\overline{INT}_L$   | $\overline{INT}_R$   | Interrupt Flag. $\overline{INT}_L$ is set when right port writes location 1FFE and is cleared when left port reads location 1FFE. $\overline{INT}_R$ is set when left port writes location 1FFF <sup>[4]</sup> and is cleared when right port reads location 1FFF <sup>[4]</sup> .                                 |
| $\overline{BUSY}_L$  | $\overline{BUSY}_R$  | Busy flag  |
| M/S                  |                      | Master or slave select   |
| V <sub>CC</sub>      |                      | Power  |
| GND                  |                      | Ground   |

## Architecture

The CY7C144E consists of an array of 8K words of 8 bits each of dual-port RAM cells, I/O, address lines, and control signals ( $\overline{CE}$ ,  $\overline{OE}$ , R/W). These control pins permit independent access for reads/writes to any location in memory. To handle simultaneous writes or reads to the same location, a  $\overline{BUSY}$  pin is provided on each port. Two interrupt ( $\overline{INT}$ ) pins can be used

for port-to-port communication. Two semaphore ( $\overline{SEM}$ ) control pins are used for allocating shared resources. With the M/S pin, the CY7C144E can function as a Master ( $\overline{BUSY}$  pins are outputs) or as a slave ( $\overline{BUSY}$  pins are inputs). The CY7C144E has an automatic power-down feature controlled by  $\overline{CE}$ . Each port is provided with its own output enable control ( $\overline{OE}$ ), which allows data to be read from the device.

### Note

4. 8K x 8 (CY7C144E): 1FFE(left port) and 1FFF(right port).

## Functional Overview

### Write Operation

Data must be set up for a duration of  $t_{SD}$  before the rising edge of R / W to guarantee a valid write. A write operation is controlled by either the OE pin (see Figure 7 on page 12) or the R/W pin (see Figure 8 on page 12). Data can be written to the device  $t_{HZOE}$  after the OE is deasserted or  $t_{HZWE}$  after the falling edge of R/W. Required inputs for non-contention operations are summarized in Table 1.

If a location is being written to by one port and the opposite port attempts to read that location, a port-to-port flowthrough delay must be met before the data is read on the output; otherwise the data read is not deterministic. Data will be valid on the port  $t_{DDD}$  after the data is presented on the other port.

### Read Operation

When reading the device, the user must assert both the  $\overline{OE}$  and CE pins. Data will be available  $t_{ACE}$  after CE or  $t_{DOE}$  after OE are asserted. If the user of the CY7C144E wishes to access a semaphore flag, then the SEM pin must be asserted instead of the CE pin.

Table 1. Non-Contending Read/Write

| Inputs |   |    |     | Outputs            | Operation              |
|--------|---|----|-----|--------------------|------------------------|
| CE     | R/W   | OE | SEM | I/O <sub>0-7</sub> |                        |
| H      | X   | X  | H   | High Z             | Power-down             |
| H      | H   | L  | L   | Data out           | Read data in semaphore |
| X      | X   | H  | X   | High Z             | I/O lines disabled     |
| H      |  | X  | L   | Data in            | Write to semaphore     |
| L      | H   | L  | H   | Data out           | Read                   |
| L      | L   | X  | H   | Data in            | Write                  |
| L      | X   | X  | L   |                    | Illegal condition      |

### Interrupts

The interrupt flag ( $\overline{INT}$ ) permits communications between ports. When the left port writes to location 1FFF, the right port's interrupt flag ( $INT_R$ ) is set. This flag is cleared when the right port reads that same location. Setting the left port's interrupt flag

( $\overline{INT}_L$ ) is accomplished when the right port writes to location 1FFE. This flag is cleared when the left port reads the specified location 1FFE. The message at 1FFF or 1FFE is user-defined. See Table 2 for input requirements for INT.  $INT_R$  and  $INT_L$  are push-pull outputs and do not require pull-up resistors to operate.

Table 2. Interrupt Operation Example (assumes  $\overline{BUSY}_L = \overline{BUSY}_R = \text{HIGH}$ )

| Function                     | Left Port |    |    |                              |     | Right Port |    |    |                              |     |
|------------------------------|-----------|----|----|------------------------------|-----|------------|----|----|------------------------------|-----|
|                              | R/W       | CE | OE | A <sub>0-12</sub> (CY7C144E) | INT | R/W        | CE | OE | A <sub>0-12</sub> (CY7C144E) | INT |
| Set left $\overline{INT}$    | X         | X  | X  | X                            | L   | L          | L  | X  | 1FFE                         | X   |
| Reset left $\overline{INT}$  | X         | L  | L  | 1FFE                         | H   | X          | L  | L  | X                            | X   |
| Set right $\overline{INT}$   | L         | L  | X  | 1FFF                         | X   | X          | X  | X  | X                            | L   |
| Reset right $\overline{INT}$ | X         | X  | X  | X                            | X   | X          | L  | L  | 1FFF                         | H   |

### Busy

The CY7C144E provides on-chip arbitration to alleviate simultaneous memory location access (contention). If both ports' CEs are asserted and an address match occurs within  $t_{PS}$  of each other the Busy logic determines which port has access. If

$t_{PS}$  is violated, one port will definitely gain permission to the location, but it is not guaranteed which one.  $BUSY$  will be asserted  $t_{BLA}$  after an address match or  $t_{BLC}$  after CE is taken LOW.  $BUSY_L$  and  $BUSY_R$  in master mode are push-pull outputs and do not require pull-up resistors to operate.

### Master/Slave

An  $\overline{M/S}$  pin is provided in order to expand the word width by configuring the device as either a master or a slave. The  $\overline{BUSY}$  output of the master is connected to the  $\overline{BUSY}$  input of the slave. This enables the device to interface to a master device with no external components. Writing of slave devices must be delayed until after the  $\overline{BUSY}$  input has settled. Otherwise, the slave chip may begin a write cycle during a contention situation. When presented a HIGH input, the  $\overline{M/S}$  pin allows the device to be used as a master and therefore the  $\overline{BUSY}$  line is an output.  $\overline{BUSY}$  can then be used to send the arbitration outcome to a slave.

### Semaphore Operation

The CY7C144E provides eight semaphore latches which are separate from the dual-port memory locations. Semaphores are used to reserve resources that are shared between the two ports. The state of the semaphore indicates that a resource is in use. For example, if the left port wants to request a given resource, it sets a latch by writing a 0 to a semaphore location. The left port then verifies its success in setting the latch by reading it. After writing to the semaphore,  $\overline{SEM}$  or  $\overline{OE}$  must be deasserted for  $t_{SOP}$  before attempting to read the semaphore. The semaphore value is available  $t_{SWRD} + t_{DOE}$  after the rising edge of the semaphore write. If the left port was successful (reads a 0), it assumes control over the shared resource, otherwise (reads a 1) it assumes the right port has control and continues to poll the semaphore. When the right side has relinquished control of the semaphore (by writing a 1), the left side will succeed in gaining control of the semaphore. If the left

side no longer requires the semaphore, a 1 is written to cancel its request.

Semaphores are accessed by asserting  $\overline{SEM}$  LOW. The  $\overline{SEM}$  pin functions as a chip enable for the semaphore latches ( $\overline{CE}$  must remain HIGH during  $\overline{SEM}$  LOW).  $A_{0-2}$  represents the semaphore address.  $\overline{OE}$  and R/W are used in the same manner as a normal memory access. When writing or reading a semaphore, the other address pins have no effect.

When writing to the semaphore, only  $I/O_0$  is used. If a 0 is written to the left port of an unused semaphore, a 1 appears at the same semaphore address on the right port. That semaphore can now only be modified by the side showing 0 (the left port in this case). If the left port now relinquishes control by writing a 1 to the semaphore, the semaphore will be set to 1 for both sides. However, if the right port had requested the semaphore (written a 0) while the left port had control, the right port would immediately own the semaphore as soon as the left port released it. Table 3 shows sample semaphore operations.

When reading a semaphore, all eight data lines output the semaphore value. The read value is latched in an output register to prevent the semaphore from changing state during a write from the other port. If both ports attempt to access the semaphore within  $t_{SPS}$  of each other, the semaphore is definitely obtained by one side or the other, but there is no guarantee which side controls the semaphore. Initialization of the semaphore is not automatic and must be reset during initialization program at power-up. All Semaphores on both sides should have a one written into them at initialization from both sides to assure that they are free when needed.

**Table 3. Semaphore Operation Example**

| Function                         | I/O <sub>0-7</sub> Left | I/O <sub>0-7</sub> Right | Status                                    |
|----------------------------------|-------------------------|--------------------------|---|
| No action                        | 1                       | 1                        | Semaphore free                            |
| Left port writes semaphore       | 0                       | 1                        | Left port obtains semaphore               |
| Right port writes 0 to semaphore | 0                       | 1                        | Right side is denied access               |
| Left port writes 1 to semaphore  | 1                       | 0                        | Right port is granted access to semaphore |
| Left port writes 0 to semaphore  | 1                       | 0                        | No change. Left port is denied access     |
| Right port writes 1 to semaphore | 0                       | 1                        | Left port obtains semaphore               |
| Left port writes 1 to semaphore  | 1                       | 1                        | No port accessing semaphore address       |
| Right port writes 0 to semaphore | 1                       | 0                        | Right port obtains semaphore              |
| Right port writes 1 to semaphore | 1                       | 1                        | No port accessing semaphore               |
| Left port writes 0 to semaphore  | 0                       | 1                        | Left port obtains semaphore               |
| Left port writes 1 to semaphore  | 1                       | 1                        | No port accessing semaphore               |

## Maximum Ratings

Exceeding maximum ratings <sup>[5]</sup> may shorten the useful life of the device. User guidelines are not tested.

Storage temperature ..... -65 °C to +150 °C  
 Ambient temperature  
 with power applied ..... -55 °C to +125 °C  
 Supply voltage to ground potential ..... -0.3 V to +7.0 V  
 DC voltage applied to outputs  
 in High Z state ..... -0.5 V to +7.0 V  
 DC input voltage <sup>[6]</sup> ..... -0.5 V to +7.0 V

Output current into outputs (LOW) ..... 20 mA  
 Static discharge voltage  
 (per MIL-STD-883, Method 3015) ..... >2001 V  
 Latch-up current ..... >200 mA

## Operating Range

| Range      | Ambient Temperature | V <sub>CC</sub> |
|------------|---------------------|-----------------|
| Commercial | 0 °C to +70 °C      | 5 V ± 10%       |
| Industrial | -40 °C to +85 °C    | 5 V ± 10%       |

## Electrical Characteristics

Over the operating range

| Parameter        | Description                                 | Test Conditions   | 7C144E-15  |     |      | 7C144E-25 |     |      | 7C144E-55 |     |      | Unit |    |
|------------------|---|---|------------|-----|------|-----------|-----|------|-----------|-----|------|------|----|
|                  |   |   | Min        | Typ | Max  | Min       | Typ | Max  | Min       | Typ | Max  |      |    |
| V <sub>OH</sub>  | Output HIGH voltage                         | V <sub>CC</sub> = Min, I <sub>OH</sub> = -4.0 mA  | 2.4        | -   | -    | 2.4       | -   | -    | 2.4       | -   | -    | V    |    |
| V <sub>OL</sub>  | Output LOW voltage                          | V <sub>CC</sub> = Min, I <sub>OL</sub> = 4.0 mA   | -          | -   | 0.4  | -         | -   | 0.4  | -         | -   | 0.4  | V    |    |
| V <sub>IH</sub>  | Input HIGH voltage                          |   | 2.2        | -   | -    | 2.2       | -   | -    | 2.2       | -   | -    | V    |    |
| V <sub>IL</sub>  | Input LOW voltage                           |   | -          | -   | 0.8  | -         | -   | 0.8  | -         | -   | 0.8  | V    |    |
| I <sub>IX</sub>  | Input leakage current                       | GND ≤ V <sub>I</sub> ≤ V <sub>CC</sub>  | -10        | -   | +10  | -10       | -   | +10  | -10       | -   | +10  | μA   |    |
| I <sub>OZ</sub>  | Output leakage current                      | Outputs disabled, GND ≤ V <sub>O</sub> ≤ V <sub>CC</sub>  | -10        | -   | +10  | -10       | -   | +10  | -10       | -   | +10  | μA   |    |
| I <sub>CC</sub>  | Operating current                           | V <sub>CC</sub> = Max,<br>I <sub>OUT</sub> = 0 mA,<br>Outputs disabled  | Commercial | -   | 190  | 280       | -   | 180  | 275       | -   | 180  | 275  | mA |
|                  |   |   | Industrial | -   | 215  | 305       | -   | 215  | 305       | -   | 215  | 305  |    |
| I <sub>SB1</sub> | Standby current<br>(Both ports TTL levels)  | $\overline{CE}_L$ and $\overline{CE}_R \geq V_{IH}$ ,<br>f = f <sub>MAX</sub> <sup>[7]</sup>  | Commercial | -   | 50   | 70        | -   | 45   | 65        | -   | 45   | 65   | mA |
|                  |   |   | Industrial | -   | 65   | 95        | -   | 65   | 95        | -   | 65   | 95   |    |
| I <sub>SB2</sub> | Standby current<br>(One port TTL level)     | $\overline{CE}_L$ or $\overline{CE}_R \geq V_{IH}$ ,<br>f = f <sub>MAX</sub> <sup>[7]</sup>   | Commercial | -   | 120  | 180       | -   | 110  | 160       | -   | 110  | 160  | mA |
|                  |   |   | Industrial | -   | 135  | 205       | -   | 135  | 205       | -   | 135  | 205  |    |
| I <sub>SB3</sub> | Standby current<br>(Both ports CMOS levels) | Both ports,<br>CE and $\overline{CE}_R \geq V_{CC} - 0.2$ V,<br>V <sub>IN</sub> ≥ V <sub>CC</sub> - 0.2 V or<br>V <sub>IN</sub> ≤ 0.2 V,<br>f = 0 <sup>[7]</sup>  | Commercial | -   | 0.05 | 0.5       | -   | 0.05 | 0.5       | -   | 0.05 | 0.5  | mA |
|                  |   |   | Industrial | -   | 0.05 | 0.5       | -   | 0.05 | 0.5       | -   | 0.05 | 0.5  |    |
| I <sub>SB4</sub> | Standby current<br>(One port CMOS level)    | One port,<br>CE <sub>L</sub> or CE <sub>R</sub> ≥ V <sub>CC</sub> - 0.2 V,<br>V <sub>IN</sub> ≥ V <sub>CC</sub> - 0.2 V or<br>V <sub>IN</sub> ≤ 0.2 V,<br>Active Port outputs,<br>f = f <sub>MAX</sub> <sup>[7]</sup> | Commercial | -   | 110  | 160       | -   | 100  | 140       | -   | 100  | 140  | mA |
|                  |   |   | Industrial | -   | 125  | 175       | -   | 125  | 175       | -   | 125  | 175  |    |

### Notes

- The voltage on any input or I/O pin cannot exceed the power pin during power-up.
- Pulse width < 20 ns.
- f<sub>MAX</sub> = 1/t<sub>RC</sub> = All inputs cycling at f = 1/t<sub>RC</sub> (except output enable). f = 0 means no address or control lines change. This applies only to inputs at CMOS level standby I<sub>SB3</sub>.

## Capacitance

Tested initially and after any design or process changes that may affect these parameters.

| Parameter | Description        | Test Conditions  | Max | Unit |
|-----------|--------------------|--|-----|------|
| $C_{IN}$  | Input capacitance  | $T_A = 25\text{ }^\circ\text{C}$ , $f = 1\text{ MHz}$ ,<br>$V_{CC} = 5.0\text{ V}$ | 10  | pF   |
| $C_{OUT}$ | Output capacitance |  | 10  | pF   |

## AC Test Loads and Waveforms

Figure 3. AC Test Loads and Waveforms

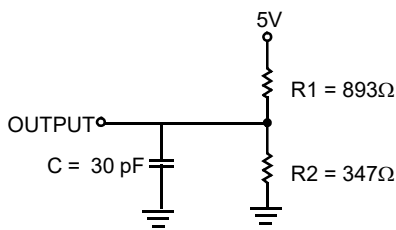

(a) Normal Load (Load1)

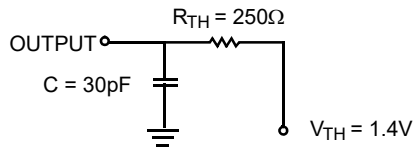

(b) Thévenin Equivalent (Load 1)

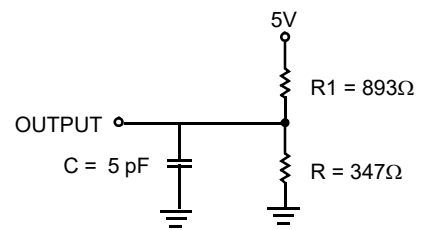

(c) Three-State Delay (Load 3)

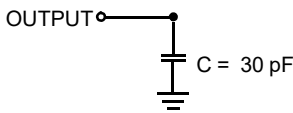

Load (Load 2)

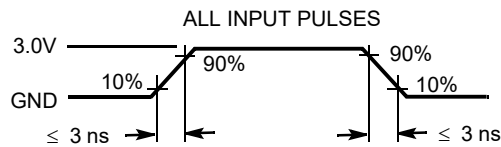



## Switching Characteristics

Over the operating range

| Parameter <sup>[8]</sup> | Description                         | 7C144E-15 |     | 7C144E-25 |     | 7C144E-55 |     | Unit |
|--------------------------|-------------------------------------|-----------|-----|-----------|-----|-----------|-----|------|
|                          |                                     | Min       | Max | Min       | Max | Min       | Max |      |
| <b>Read Cycle</b>        |                                     |           |     |           |     |           |     |      |
| $t_{RC}$                 | Read cycle time                     | 15        | –   | 25        | –   | 55        | –   | ns   |
| $t_{AA}$                 | Address to data valid               | –         | 15  | –         | 25  | –         | 55  | ns   |
| $t_{OHA}$                | Output hold from address change     | 3         | –   | 3         | –   | 3         | –   | ns   |
| $t_{ACE}$                | $\overline{CE}$ LOW to data valid   | –         | 15  | –         | 25  | –         | 55  | ns   |
| $t_{DOE}$                | $\overline{OE}$ LOW to data valid   | –         | 10  | –         | 15  | –         | 25  | ns   |
| $t_{LZOE}^{[9, 10]}$     | $\overline{OE}$ Low to Low Z        | 3         | –   | 3         | –   | 3         | –   | ns   |
| $t_{HZOE}^{[9, 10]}$     | $\overline{OE}$ HIGH to High Z      | –         | 10  | –         | 15  | –         | 25  | ns   |
| $t_{LZCE}^{[9, 10]}$     | $\overline{CE}$ LOW to Low Z        | 3         | –   | 3         | –   | 3         | –   | ns   |
| $t_{HZCE}^{[9, 10]}$     | $\overline{CE}$ HIGH to High Z      | –         | 10  | –         | 15  | –         | 25  | ns   |
| $t_{PU}^{[10]}$          | $\overline{CE}$ LOW to power-up     | 0         | –   | 0         | –   | 0         | –   | ns   |
| $t_{PD}^{[10]}$          | $\overline{CE}$ HIGH to power-down  | –         | 15  | –         | 25  | –         | 55  | ns   |
| <b>Write Cycle</b>       |                                     |           |     |           |     |           |     |      |
| $t_{WC}$                 | Write cycle time                    | 15        | –   | 25        | –   | 55        | –   | ns   |
| $t_{SCE}$                | $\overline{CE}$ LOW to write end    | 12        | –   | 20        | –   | 45        | –   | ns   |
| $t_{AW}$                 | Address setup to write end          | 12        | –   | 20        | –   | 45        | –   | ns   |
| $t_{HA}$                 | Address hold from write end         | 0         | –   | 2         | –   | 2         | –   | ns   |
| $t_{SA}$                 | Address setup to write start        | 0         | –   | 0         | –   | 0         | –   | ns   |
| $t_{PWE}$                | Write pulse width                   | 12        | –   | 20        | –   | 40        | –   | ns   |
| $t_{SD}$                 | Data setup to write end             | 10        | –   | 15        | –   | 25        | –   | ns   |
| $t_{HD}$                 | Data hold from write end            | 0         | –   | 0         | –   | 0         | –   | ns   |
| $t_{HZWE}^{[10]}$        | $R/\overline{W}$ LOW to High Z      | –         | 10  | –         | 15  | –         | 25  | ns   |
| $t_{LZWE}^{[10]}$        | $R/\overline{W}$ HIGH to Low Z      | 3         | –   | 3         | –   | 3         | –   | ns   |
| $t_{WDD}^{[11]}$         | Write pulse to data delay           | –         | 30  | –         | 50  | –         | 70  | ns   |
| $t_{DDD}^{[11]}$         | Write data valid to read data valid | –         | 25  | –         | 30  | –         | 40  | ns   |

### Notes

8. Test conditions assume signal transition time of 3 ns or less, timing reference levels of 1.5 V, input pulse levels of 0 to 3.0 V, and output loading of the specified  $I_O/I_{OH}$  and 30-pF load capacitance.
9. At any given temperature and voltage condition for any given device,  $t_{HZCE}$  is less than  $t_{LZCE}$  and  $t_{HZOE}$  is less than  $t_{LZOE}$ .
10. Test conditions used are Load 3. This parameter is guaranteed but not tested.
11. For information on part-to-part delay through RAM cells from writing port to reading port, refer to Read Timing with Port-to-Port Delay waveform.

**Switching Characteristics (continued)**

Over the operating range

| Parameter <sup>[8]</sup>                | Description  | 7C144E-15 |     | 7C144E-25 |     | 7C144E-55 |     | Unit |
|---|--|-----------|-----|-----------|-----|-----------|-----|------|
|   |  | Min       | Max | Min       | Max | Min       | Max |      |
| <b>Busy Timing <sup>[12]</sup></b>      |  |           |     |           |     |           |     |      |
| t <sub>BLA</sub>                        | BUS $\overline{\text{Y}}$ LOW from address match                   | –         | 15  | –         | 20  | –         | 30  | ns   |
| t <sub>BHA</sub>                        | BUS $\overline{\text{Y}}$ HIGH from address mismatch               | –         | 15  | –         | 20  | –         | 30  | ns   |
| t <sub>BLC</sub>                        | BUS $\overline{\text{Y}}$ LOW from $\overline{\text{CE}}$ LOW      | –         | 15  | –         | 20  | –         | 30  | ns   |
| t <sub>BHC</sub>                        | BUS $\overline{\text{Y}}$ HIGH from $\overline{\text{CE}}$ HIGH    | –         | 15  | –         | 20  | –         | 30  | ns   |
| t <sub>PS</sub>                         | Port setup for priority  | 5         | –   | 5         | –   | 5         | –   | ns   |
| t <sub>WB</sub>                         | R/ $\overline{\text{W}}$ LOW after BUS $\overline{\text{Y}}$ LOW   | 0         | –   | 0         | –   | 0         | –   | ns   |
| t <sub>WH</sub>                         | R/ $\overline{\text{W}}$ HIGH after BUS $\overline{\text{Y}}$ HIGH | 13        | –   | 20        | –   | 30        | –   | ns   |
| t <sub>BDD</sub>                        | BUS $\overline{\text{Y}}$ HIGH to data valid <sup>[13]</sup>       | –         | 15  | –         | 25  | –         | 55  | ns   |
| <b>Interrupt Timing <sup>[12]</sup></b> |  |           |     |           |     |           |     |      |
| t <sub>INS</sub>                        | $\overline{\text{INT}}$ Set time                                   | –         | 15  | –         | 25  | –         | 35  | ns   |
| t <sub>INR</sub>                        | $\overline{\text{INT}}$ Reset time                                 | –         | 15  | –         | 25  | –         | 35  | ns   |
| <b>Semaphore Timing</b>                 |  |           |     |           |     |           |     |      |
| t <sub>SOP</sub>                        | SEm flag update pulse ( $\overline{\text{OE}}$ or SEM)             | 10        | –   | 10        | –   | 20        | –   | ns   |
| t <sub>SWRD</sub>                       | SEm flag write to read time  | 5         | –   | 5         | –   | 5         | –   | ns   |
| t <sub>SPS</sub>                        | SEm flag contention window   | 5         | –   | 5         | –   | 5         | –   | ns   |
| t <sub>SAA</sub>                        | SEM Address Access Time  | –         | 15  | –         | 20  | –         | 20  | ns   |

**Note**

12. Test conditions used are Load 2.

 13. t<sub>BDD</sub> is a calculated parameter and is the greater of t<sub>WDD</sub> – t<sub>PWE</sub> (actual) or t<sub>DD</sub> – t<sub>SD</sub> (actual).

## Switching Waveforms

Figure 4. Read Cycle No. 1 (Either Port Address Access) [14, 15]

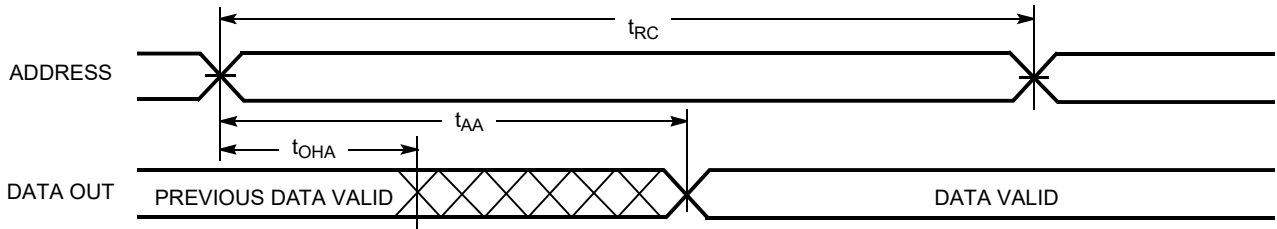

Figure 5. Read Cycle No. 2 (Either Port  $\overline{CE}/\overline{OE}$  Access) [14, 16, 17]

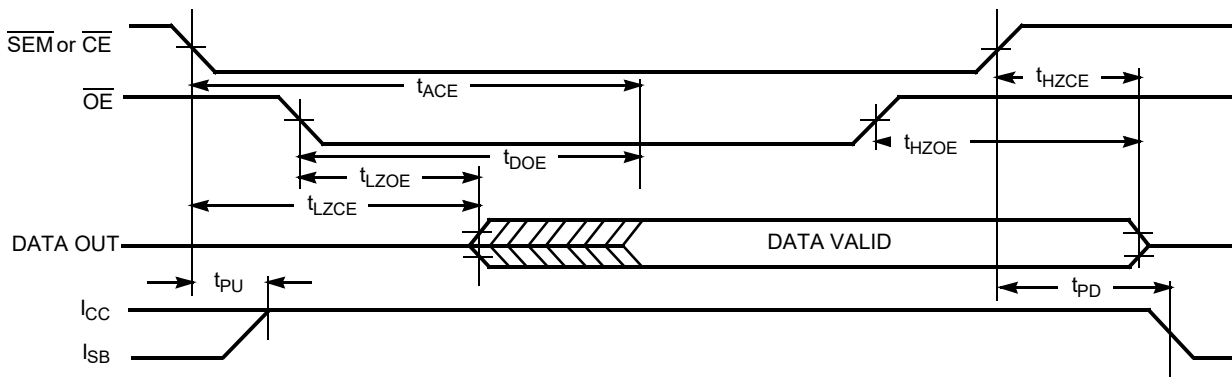
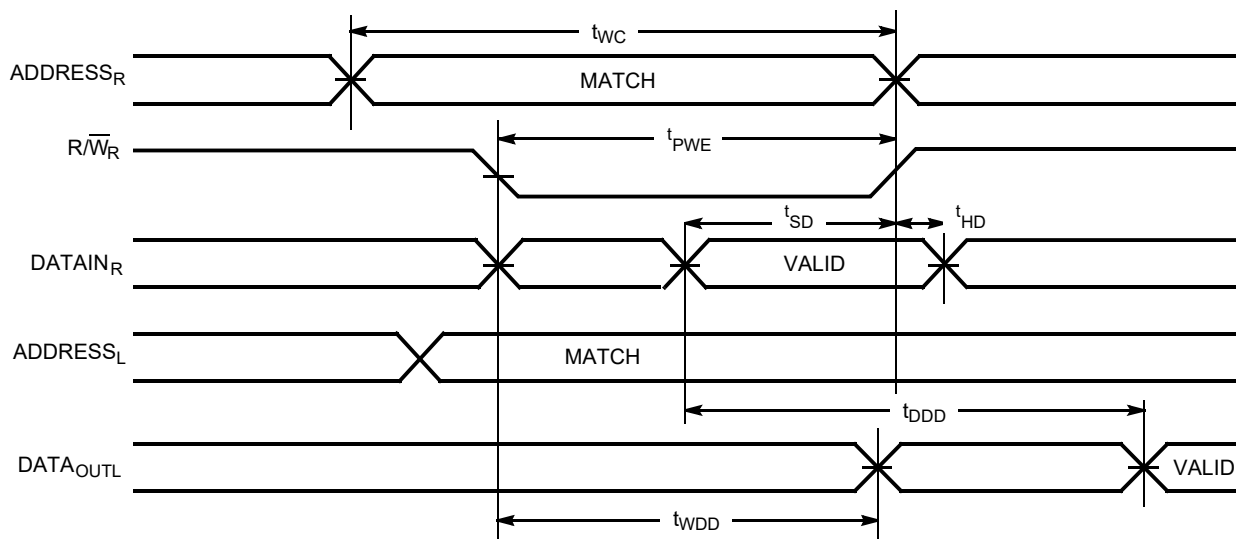

Figure 6. Read Timing with Port-to-port Delay ( $M/\overline{S} = L$ ) [18, 19]



### Notes

14. R/W is HIGH for read cycle.
15. Device is continuously selected  $\overline{CE} = \text{LOW}$  and  $\overline{OE} = \text{LOW}$ . This waveform cannot be used for semaphore reads.
16. Address valid prior to or coincident with  $\overline{CE}$  transition LOW.
17.  $\overline{CE}_L = L$ ,  $\overline{SEM} = H$  when accessing RAM.  $\overline{CE} = H$ ,  $\overline{SEM} = L$  when accessing semaphores.
18.  $\overline{BUSY} = \text{HIGH}$  for the writing port.
19.  $\overline{CE}_L = \overline{CE}_R = \text{LOW}$ .

Switching Waveforms (continued)

Figure 7. Write Cycle No. 1 ( $\overline{OE}$  Three-state Data I/Os (Either Port)) [20, 21, 22]

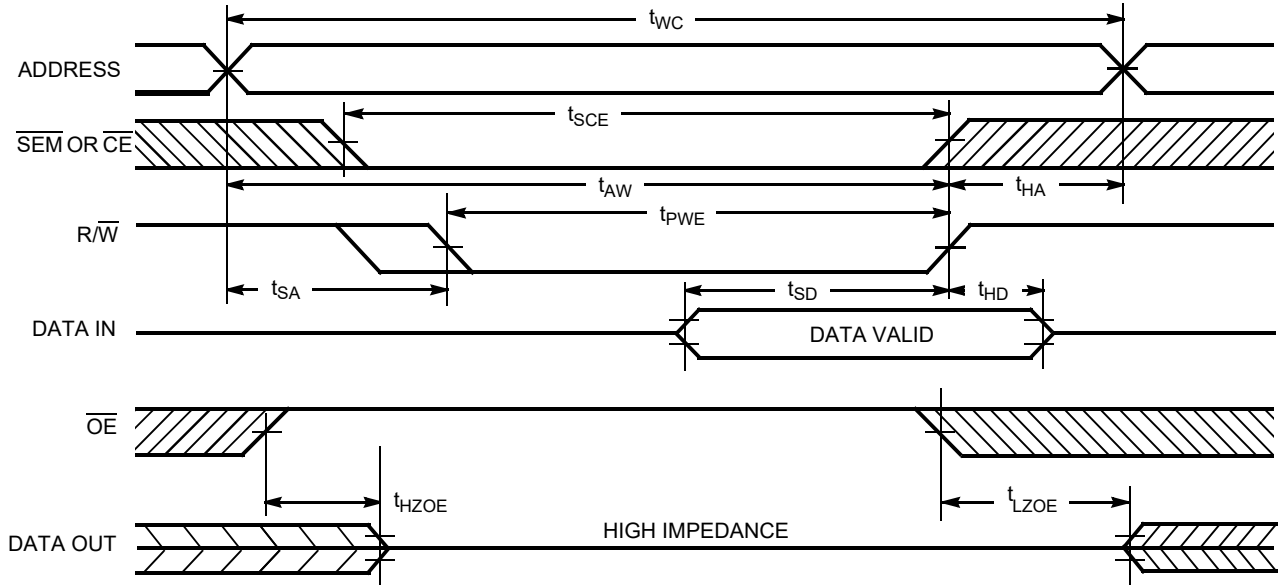
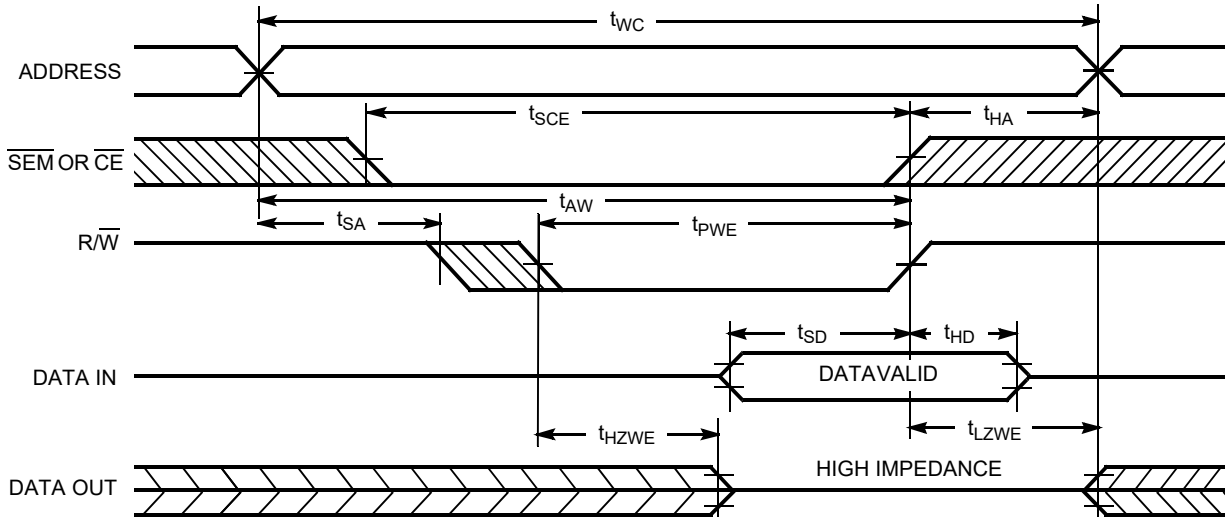
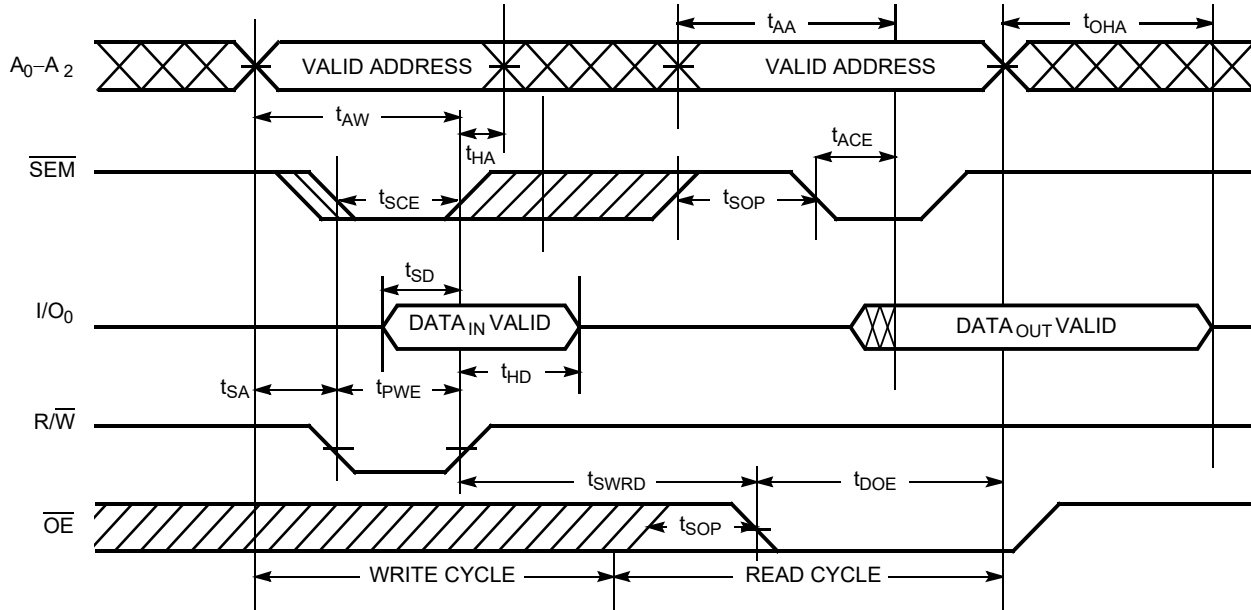
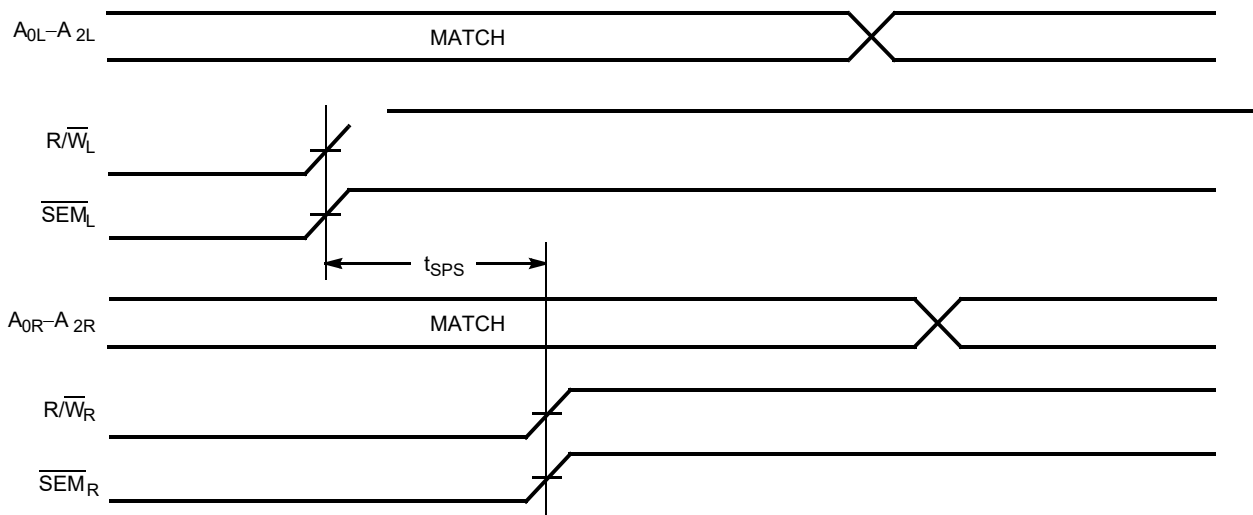

Figure 8. Write Cycle No. 2 ( $\overline{R/W}$  Three-state Data I/Os (Either Port)) [20, 22, 23]



Notes

- 20. The internal write time of the memory is defined by the overlap of  $\overline{CE}$  or  $\overline{SEM}$  LOW and  $\overline{R/W}$  LOW. Both signals must be LOW to initiate a write, and either signal can terminate a write by going HIGH. The data input setup and hold timing should be referenced to the rising edge of the signal that terminates the write.
- 21. If  $\overline{OE}$  is LOW during a  $\overline{R/W}$  controlled write cycle, the write pulse width must be the larger of  $t_{PWE}$  or  $(t_{HZWE} + t_{SD})$  to allow the I/O drivers to turn off and data to be placed on the bus for the required  $t_{SD}$ . If  $\overline{OE}$  is HIGH during a  $\overline{R/W}$  controlled write cycle (as in this example), this requirement does not apply and the write pulse can be as short as the specified  $t_{PWE}$ .
- 22.  $\overline{R/W}$  must be HIGH during all address transitions.
- 23. Data I/O pins enter high impedance when  $\overline{OE}$  is held LOW during write.

**Switching Waveforms (continued)**
**Figure 9. Semaphore Read After Write Timing, Either Side [24]**

**Figure 10. Semaphore Contention [25, 26, 27]**

**Notes**

24.  $\overline{CE} = \text{HIGH}$  for the duration of the above timing (both write and read cycle).

25.  $I/O_{0R} = I/O_{0L} = \text{LOW}$  (request semaphore);  $\overline{CE}_R = \overline{CE}_L = \text{HIGH}$

26. Semaphores are reset (available to both ports) at cycle start.

27. If  $t_{SPS}$  is violated, the semaphore will definitely be obtained by one side or the other, but there is no guarantee which side will control the semaphore.

Switching Waveforms (continued)

Figure 11. Read with  $\overline{\text{BUSY}}$  (M/S = HIGH) [28]

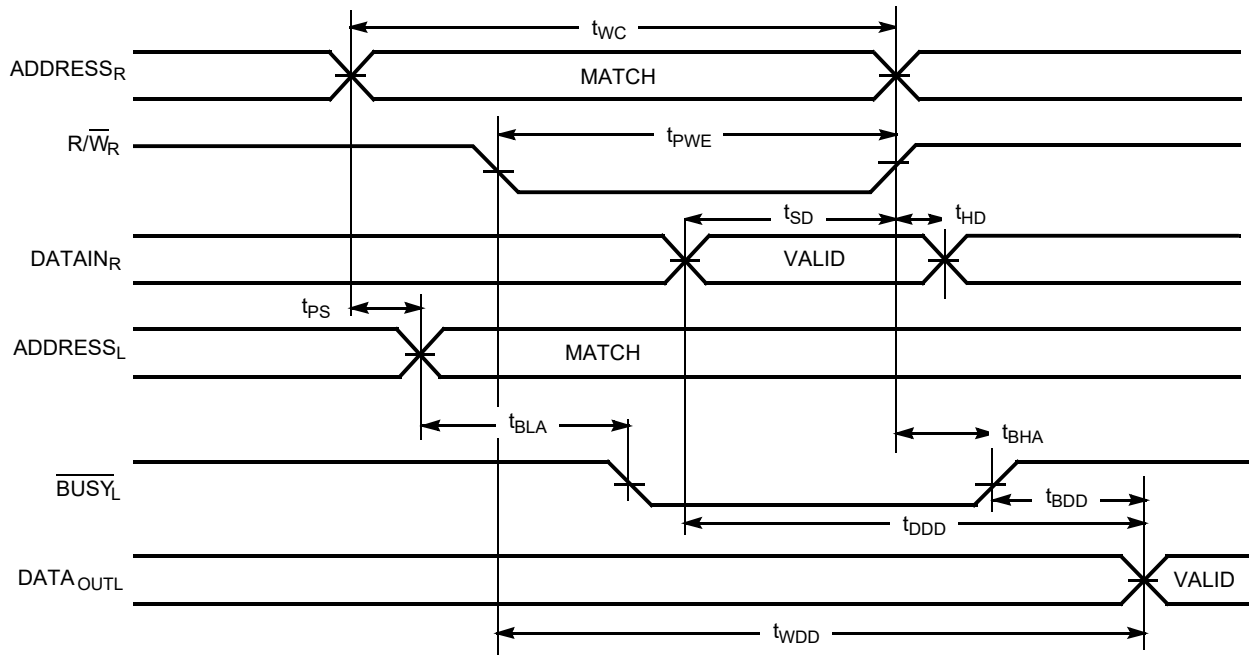
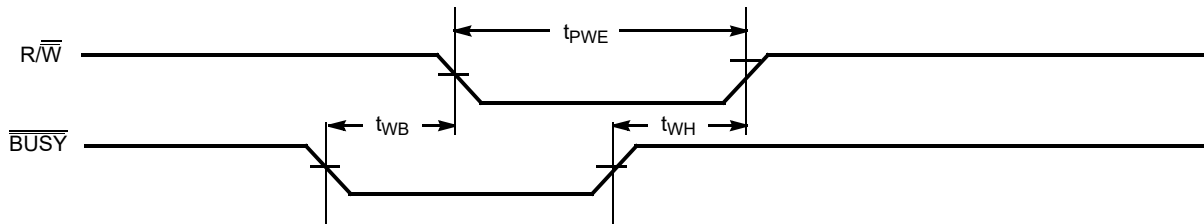

Figure 12. Write Timing with Busy Input ( $M/\overline{S} = \text{LOW}$ )



**Note**  
28.  $\overline{\text{CE}}_L = \overline{\text{CE}}_R = \text{LOW}$ .

Switching Waveforms (continued)

Figure 13. Busy Timing Diagram No. 1 ( $\overline{CE}$  Arbitration) [29]

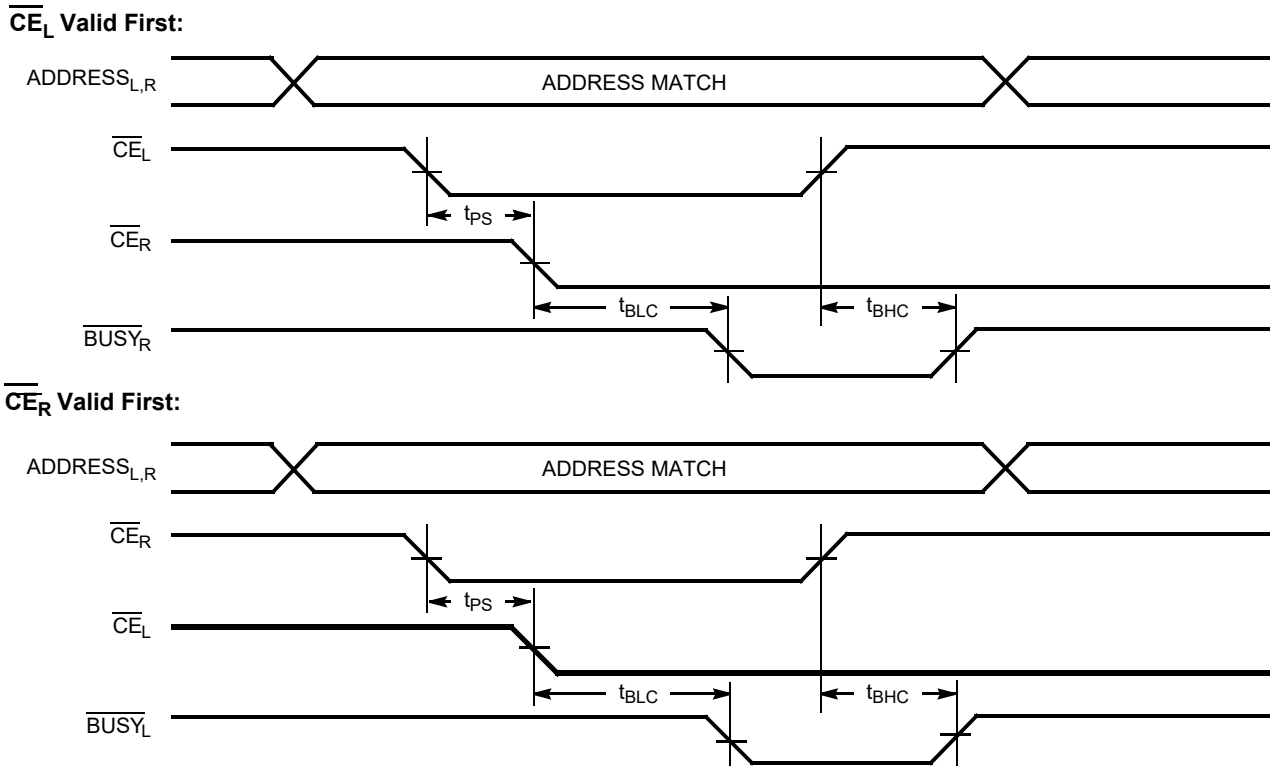
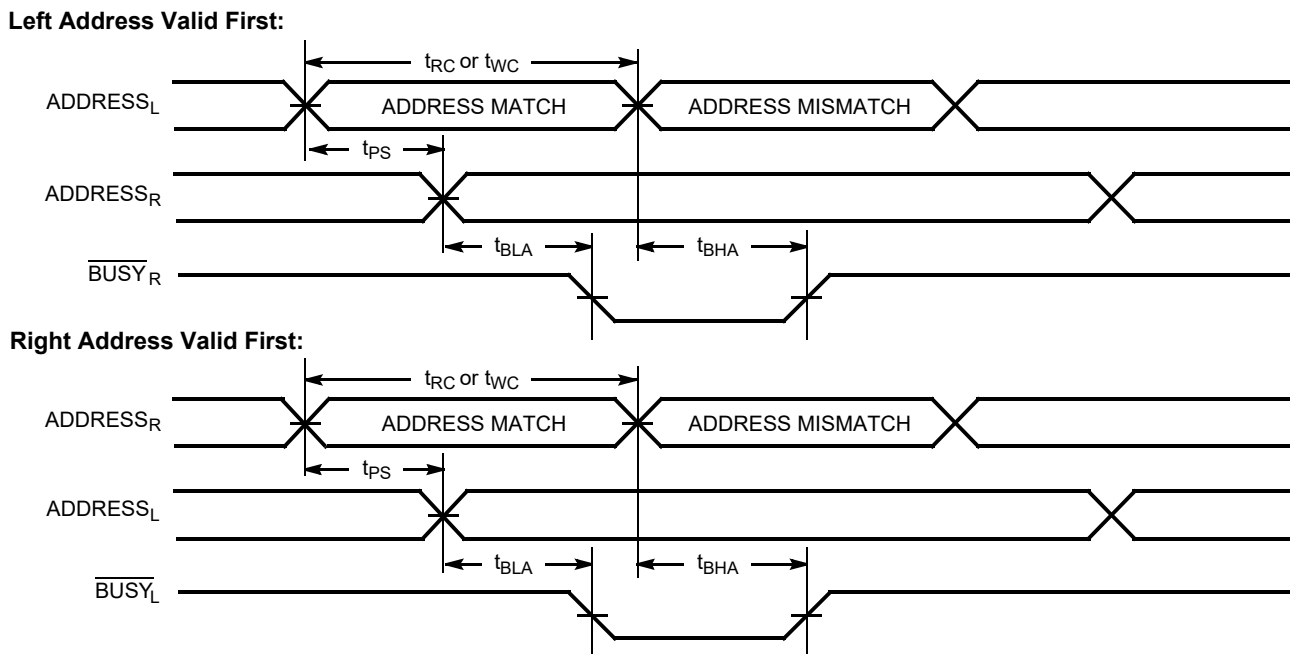

Figure 14. Busy Timing Diagram No. 2 (Address Arbitration) [29]



Note

29. If  $t_{PS}$  is violated, the busy signal will be asserted on one side or the other, but there is no guarantee on which side  $\overline{BUSY}$  will be asserted.

Switching Waveforms (continued)

Figure 15. Interrupt Timing Diagrams

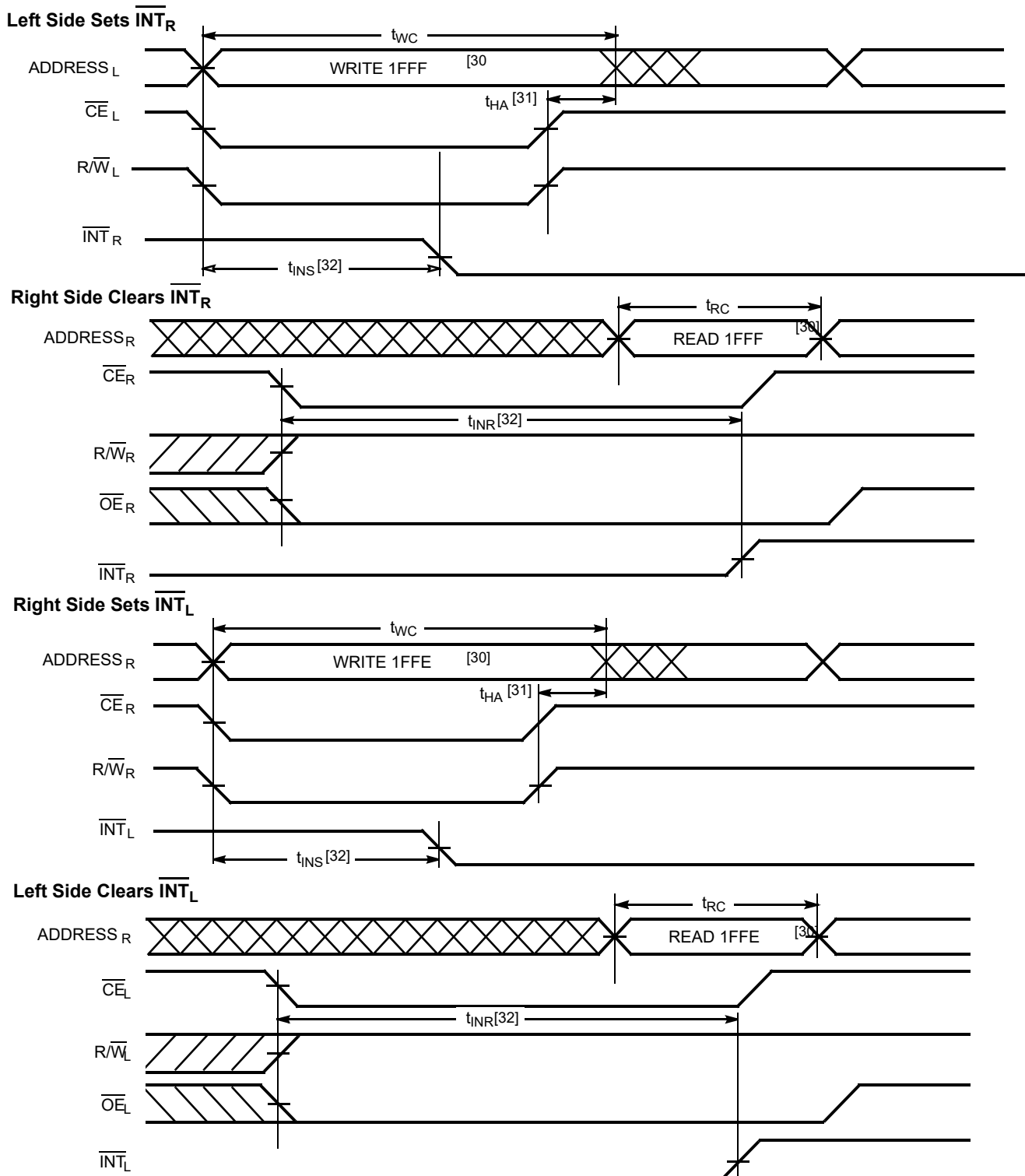

- Notes**
- 30. 8K × 8 (CY7C144E): 1FFE(left port) and 1FFF(right port).
  - 31.  $t_{HA}$  depends on which enable pin ( $\overline{CE}_L$  or  $R/\overline{W}_L$ ) is deasserted first.
  - 32.  $t_{INS}$  or  $t_{INR}$  depends on which enable pin ( $\overline{CE}_L$  or  $R/\overline{W}_L$ ) is asserted last.



Typical DC and AC Characteristics

Figure 16. Typical DC and AC Characteristics

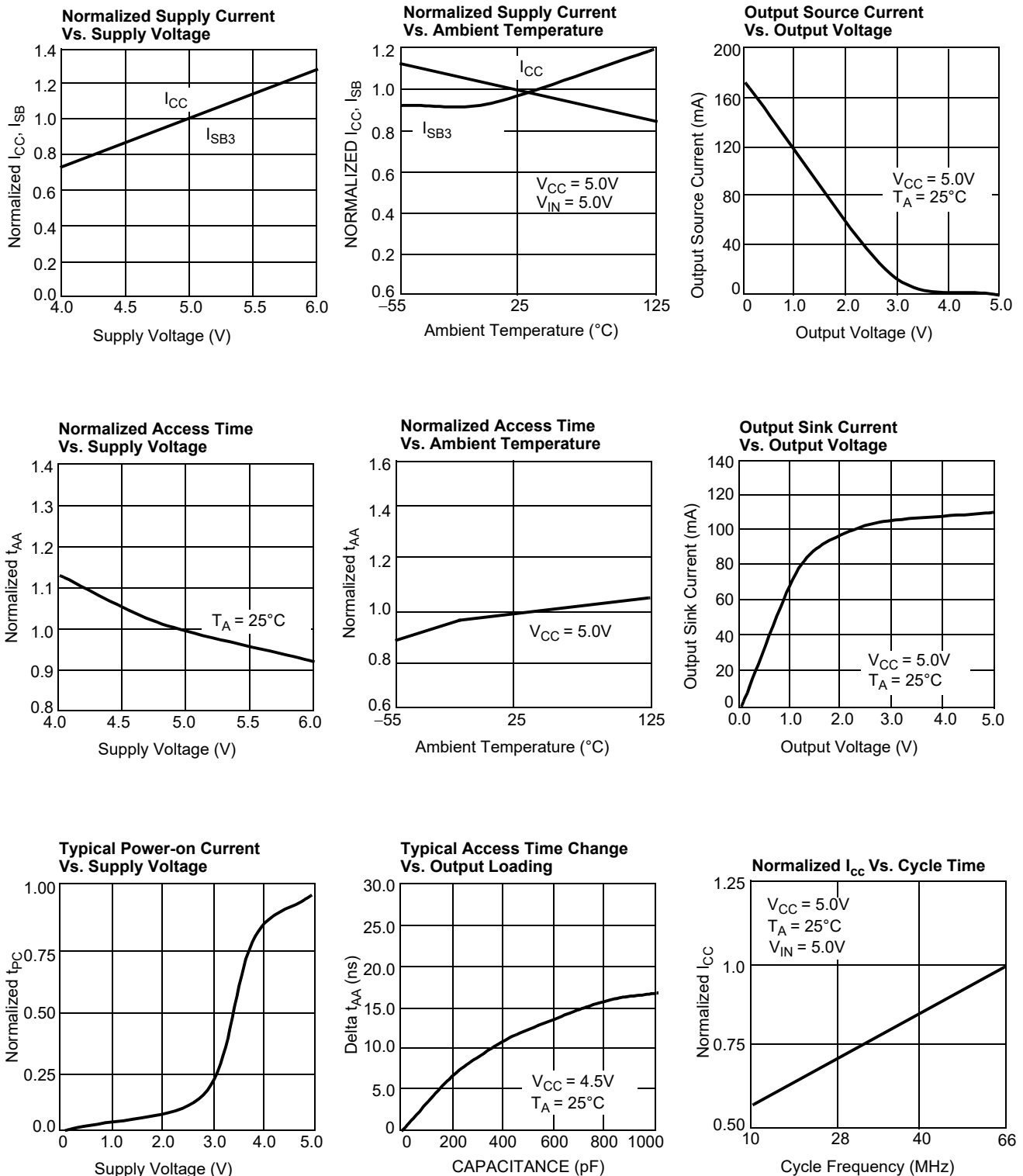

### Ordering Information

| Speed (ns) | Ordering Code  | Package Diagram | Package Type          | Operating Range |
|------------|----------------|-----------------|-----------------------|-----------------|
| 15         | CY7C144E-15AXC | 51-85046        | 64-pin TQFP (Pb-free) | Commercial      |
|            | CY7C144E-15AXI | 51-85046        | 64-pin TQFP (Pb-free) | Industrial      |
| 25         | CY7C144E-25AXC | 51-85046        | 64-pin TQFP (Pb-free) | Commercial      |
| 55         | CY7C144E-55AXC | 51-85046        | 64-pin TQFP (Pb-free) | Commercial      |
|            | CY7C144E-55JXC | 51-85005        | 68-pin PLCC (Pb-free) | Commercial      |

### Ordering Code Definitions

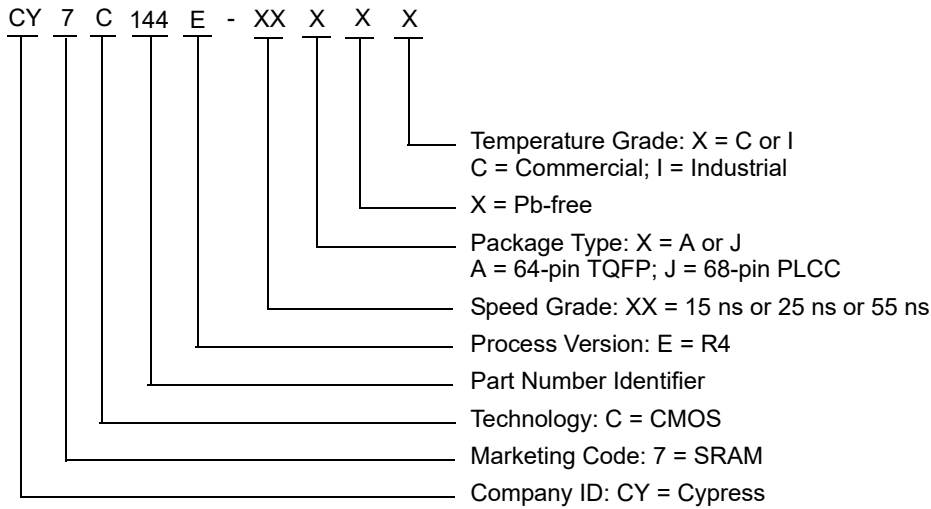

Package Diagrams

Figure 17. 64-pin TQFP (14.0 × 14.0 × 1.4 mm) Package Outline, 51-85046

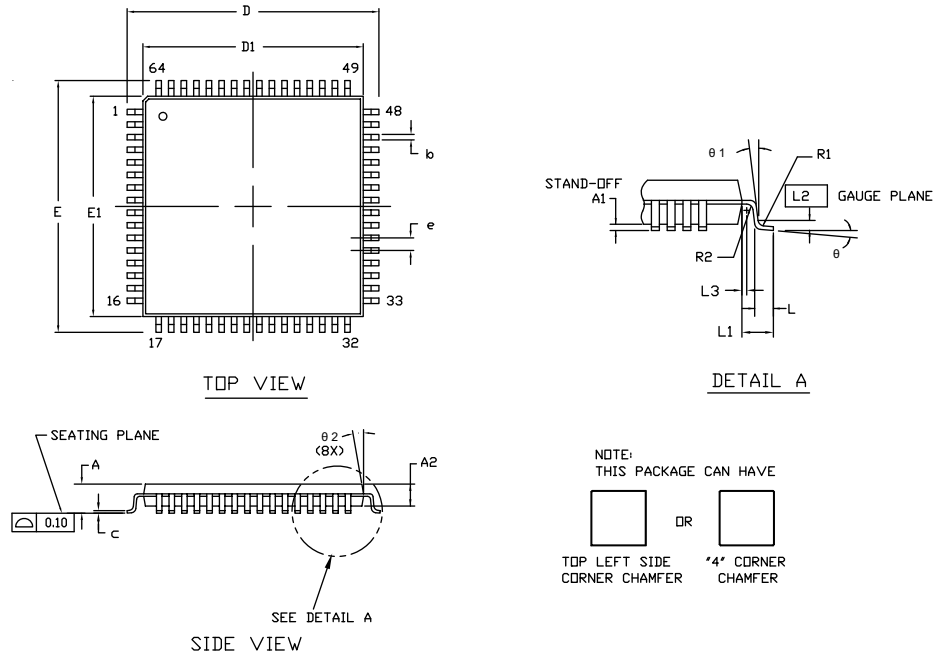

| SYMBOL | DIMENSIONS |       |       |
|--------|------------|-------|-------|
|        | MIN.       | NOM.  | MAX.  |
| A      | —          | —     | 1.60  |
| A1     | 0.05       | —     | 0.15  |
| A2     | 1.35       | 1.40  | 1.45  |
| D      | 15.75      | 16.00 | 16.25 |
| D1     | 13.95      | 14.00 | 14.05 |
| E      | 15.75      | 16.00 | 16.25 |
| E1     | 13.95      | 14.00 | 14.05 |
| R1     | 0.08       | —     | 0.20  |
| R2     | 0.08       | —     | 0.20  |
| θ      | 0°         | —     | 7°    |
| θ1     | 0°         | —     | —     |
| θ2     | 11°        | 12°   | 13°   |
| c      | —          | —     | 0.20  |
| b      | 0.30       | 0.35  | 0.40  |
| L      | 0.45       | 0.60  | 0.75  |
| L1     | 1.00 REF   |       |       |
| L2     | 0.25 BSC   |       |       |
| L3     | 0.20       | —     | —     |
| e      | 0.80 TYP   |       |       |

NOTE:

- JEDEC STD REF MS-026
- BODY LENGTH DIMENSION DOES NOT INCLUDE MOLD PROTRUSION/END FLASH. MOLD PROTRUSION/END FLASH SHALL NOT EXCEED 0.0098 in (0.25 mm) PER SIDE. BODY LENGTH DIMENSIONS ARE MAX PLASTIC BODY SIZE INCLUDING MOLD MISMATCH.
- DIMENSIONS IN MILLIMETERS

51-85046 \*H

Package Diagrams (continued)

Figure 18. 68-pin PLCC (0.958 × 0.958 Inches) Package Outline, 51-85005

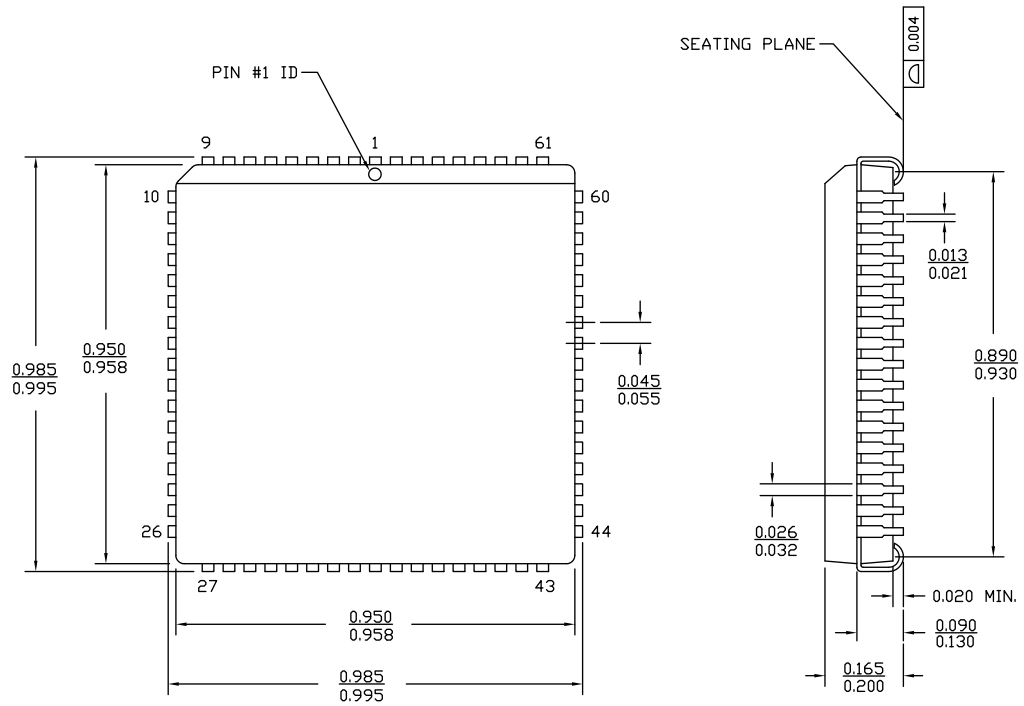

DIMENSIONS IN INCHES MIN.  
MAX.

51-85005 \*D

## Acronyms

Table 4. Acronyms

| Acronym                | Description                             |
|------------------------|---|
| CMOS                   | complementary metal oxide semiconductor |
| $\overline{\text{CE}}$ | chip enable                             |
| I/O                    | input/output                            |
| $\overline{\text{OE}}$ | output enable                           |
| SRAM                   | static random access memory             |
| TSOP                   | thin small outline package              |
| $\overline{\text{WE}}$ | write enable                            |

## Document Conventions

### Units of Measure

Table 5. Units of Measure

| Symbol        | Unit of Measure |
|---------------|-----------------|
| °C            | degree Celsius  |
| $\mu\text{A}$ | microampere     |
| mA            | milliampere     |
| ns            | nanosecond      |
| pF            | picofarad       |
| V             | volt            |
| W             | watt            |

## Document History Page

| Document Title: CY7C144E, 8K × 8 Dual-Port Static RAM with SEM, INT, BUSY<br>Document Number: 001-63982 |         |                 |                 |   |
|---|---------|-----------------|-----------------|---|
| Revision  | ECN     | Orig. of Change | Submission Date | Description of Change   |
| **  | 3038037 | ADMU            | 09/24/2010      | New data sheet.   |
| *A  | 3395887 | ADMU            | 10/05/2011      | Updated Document Title to read as "CY7C144E, 8K × 8 Dual-Port Static RAM with SEM, INT, BUSY".<br>Changed status from Preliminary to Final.<br>Removed CY7C138E and related information in all instances across the document.<br>Updated <a href="#">Ordering Information</a> :<br>Updated part numbers.<br>Completing Sunset Review. |
| *B  | 3403147 | ADMU            | 10/12/2011      | No technical updates.<br>Post to external web.  |
| *C  | 4559526 | ADMU            | 11/07/2014      | Updated <a href="#">Functional Description</a> :<br>Added "For a complete list of related documentation, click <a href="#">here</a> ." at the end.<br>Updated <a href="#">Package Diagrams</a> :<br>spec 51-85046 – Changed revision from *E to *F.   |
| *D  | 5633658 | NILE            | 02/16/2017      | Updated <a href="#">Package Diagrams</a> :<br>spec 51-85046 – Changed revision from *F to *H.<br>spec 51-85005 – Changed revision from *C to *D.<br>Removed Reference Documents.<br>Updated to new template.  |
| *E  | 6015141 | VINI            | 01/05/2018      | Updated <a href="#">Ordering Information</a> :<br>Updated part numbers.<br>Updated to new template.   |

## Sales, Solutions, and Legal Information

### Worldwide Sales and Design Support

Cypress maintains a worldwide network of offices, solution centers, manufacturer's representatives, and distributors. To find the office closest to you, visit us at [Cypress Locations](#).

#### Products

|                               |  |
|-------------------------------|--|
| Arm® Cortex® Microcontrollers | <a href="http://cypress.com/arm">cypress.com/arm</a>               |
| Automotive                    | <a href="http://cypress.com/automotive">cypress.com/automotive</a> |
| Clocks & Buffers              | <a href="http://cypress.com/clocks">cypress.com/clocks</a>         |
| Interface                     | <a href="http://cypress.com/interface">cypress.com/interface</a>   |
| Internet of Things            | <a href="http://cypress.com/iot">cypress.com/iot</a>               |
| Memory                        | <a href="http://cypress.com/memory">cypress.com/memory</a>         |
| Microcontrollers              | <a href="http://cypress.com/mcu">cypress.com/mcu</a>               |
| PSoC                          | <a href="http://cypress.com/psoc">cypress.com/psoc</a>             |
| Power Management ICs          | <a href="http://cypress.com/pmic">cypress.com/pmic</a>             |
| Touch Sensing                 | <a href="http://cypress.com/touch">cypress.com/touch</a>           |
| USB Controllers               | <a href="http://cypress.com/usb">cypress.com/usb</a>               |
| Wireless Connectivity         | <a href="http://cypress.com/wireless">cypress.com/wireless</a>     |

#### PSoC® Solutions

[PSoC 1](#) | [PSoC 3](#) | [PSoC 4](#) | [PSoC 5LP](#) | [PSoC 6 MCU](#)

#### Cypress Developer Community

[Community](#) | [Projects](#) | [Video](#) | [Blogs](#) | [Training](#) | [Components](#)

#### Technical Support

[cypress.com/support](http://cypress.com/support)

© Cypress Semiconductor Corporation, 2010–2018. This document is the property of Cypress Semiconductor Corporation and its subsidiaries, including Spansion LLC ("Cypress"). This document, including any software or firmware included or referenced in this document ("Software"), is owned by Cypress under the intellectual property laws and treaties of the United States and other countries worldwide. Cypress reserves all rights under such laws and treaties and does not, except as specifically stated in this paragraph, grant any license under its patents, copyrights, trademarks, or other intellectual property rights. If the Software is not accompanied by a license agreement and you do not otherwise have a written agreement with Cypress governing the use of the Software, then Cypress hereby grants you a personal, non-exclusive, nontransferable license (without the right to sublicense) (1) under its copyright rights in the Software (a) for Software provided in source code form, to modify and reproduce the Software solely for use with Cypress hardware products, only internally within your organization, and (b) to distribute the Software in binary code form externally to end users (either directly or indirectly through resellers and distributors), solely for use on Cypress hardware product units, and (2) under those claims of Cypress's patents that are infringed by the Software (as provided by Cypress, unmodified) to make, use, distribute, and import the Software solely for use with Cypress hardware products. Any other use, reproduction, modification, translation, or compilation of the Software is prohibited.

TO THE EXTENT PERMITTED BY APPLICABLE LAW, CYPRESS MAKES NO WARRANTY OF ANY KIND, EXPRESS OR IMPLIED, WITH REGARD TO THIS DOCUMENT OR ANY SOFTWARE OR ACCOMPANYING HARDWARE, INCLUDING, BUT NOT LIMITED TO, THE IMPLIED WARRANTIES OF MERCHANTABILITY AND FITNESS FOR A PARTICULAR PURPOSE. To the extent permitted by applicable law, Cypress reserves the right to make changes to this document without further notice. Cypress does not assume any liability arising out of the application or use of any product or circuit described in this document. Any information provided in this document, including any sample design information or programming code, is provided only for reference purposes. It is the responsibility of the user of this document to properly design, program, and test the functionality and safety of any application made of this information and any resulting product. Cypress products are not designed, intended, or authorized for use as critical components in systems designed or intended for the operation of weapons, weapons systems, nuclear installations, life-support devices or systems, other medical devices or systems (including resuscitation equipment and surgical implants), pollution control or hazardous substances management, or other uses where the failure of the device or system could cause personal injury, death, or property damage ("Unintended Uses"). A critical component is any component of a device or system whose failure to perform can be reasonably expected to cause the failure of the device or system, or to affect its safety or effectiveness. Cypress is not liable, in whole or in part, and you shall and hereby do release Cypress from any claim, damage, or other liability arising from or related to all Unintended Uses of Cypress products. You shall indemnify and hold Cypress harmless from and against all claims, costs, damages, and other liabilities, including claims for personal injury or death, arising from or related to any Unintended Uses of Cypress products.

Cypress, the Cypress logo, Spansion, the Spansion logo, and combinations thereof, WICED, PSoC, CapSense, EZ-USB, F-RAM, and Traveo are trademarks or registered trademarks of Cypress in the United States and other countries. For a more complete list of Cypress trademarks, visit [cypress.com](http://cypress.com). Other names and brands may be claimed as property of their respective owners.