

National Semiconductor is now part of
Texas Instruments.

Search <http://www.ti.com/> for the latest technical
information and details on our current products and services.

LPC660

Low Power CMOS Quad Operational Amplifier

General Description

The LPC660 CMOS Quad operational amplifier is ideal for operation from a single supply. It features a wide range of operating voltages from +5V to +15V and features rail-to-rail output swing in addition to an input common-mode range that includes ground. Performance limitations that have plagued CMOS amplifiers in the past are not a problem with this design. Input V_{OS} , drift, and broadband noise as well as voltage gain (into 100 k Ω and 5 k Ω) are all equal to or better than widely accepted bipolar equivalents, while the power supply requirement is typically less than 1 mW.

This chip is built with National's advanced Double-Poly Silicon-Gate CMOS process.

See the LPC662 datasheet for a Dual CMOS operational amplifier and LPC661 datasheet for a single CMOS operational amplifier with these same features.

Applications

- High-impedance buffer
- Precision current-to-voltage converter

- Long-term integrator
- High-impedance preamplifier
- Active filter
- Sample-and-Hold circuit
- Peak detector

Features

- Rail-to-rail output swing
- Micropower operation: (1 mW)
- Specified for 100 k Ω and 5 k Ω loads
- High voltage gain: 120 dB
- Low input offset voltage: 3 mV
- Low offset voltage drift: 1.3 $\mu\text{V}/^\circ\text{C}$
- Ultra low input bias current: 2 fA
- Input common-mode includes V^-
- Operation range from +5V to +15V
- Low distortion: 0.01% at 1 kHz
- Slew rate: 0.11 V/ μs
- Full military temp. range available

Application Circuit

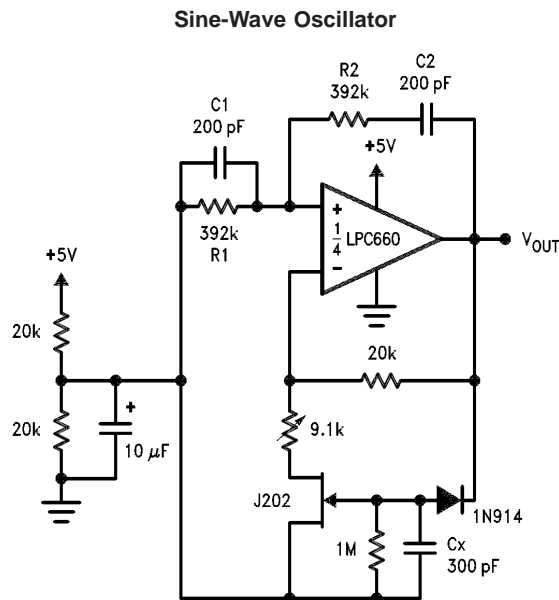

DS010547-10

Oscillator frequency is determined by R1, R2, C1, and C2:

$$f_{\text{OSC}} = 1/2\pi RC$$

where $R = R1 = R2$ and $C = C1 = C2$.

Absolute Maximum Ratings (Note 3)

If Military/Aerospace specified devices are required, please contact the National Semiconductor Sales Office/Distributors for availability and specifications.

Differential Input Voltage	±Supply Voltage
Supply Voltage ($V^+ - V^-$)	16V
Output Short Circuit to V^+	(Note 11)
Output Short Circuit to V^-	(Note 1)
Lead Temperature (Soldering, 10 sec.)	260°C
Storage Temp. Range	-65°C to +150°C
Junction Temperature (Note 2)	150°C
ESD Rating (C = 100 pF, R = 1.5 kΩ)	1000V
Power Dissipation	(Note 2)
Current at Input Pin	±5 mA
Current at Output Pin	±18 mA

Voltage at Input/Output Pin	(V^+) + 0.3V, (V^-) - 0.3V
Current at Power Supply Pin	35 mA

Operating Ratings (Note 3)

Temperature Range	
LPC660AM	-55°C ≤ T_J ≤ +125°C
LPC660AI	-40°C ≤ T_J ≤ +85°C
LPC660I	-40°C ≤ T_J ≤ +85°C
Supply Range	4.75V to 15.5V
Power Dissipation	(Note 9)
Thermal Resistance (θ_{JA}), (Note 10)	
14-Pin Ceramic DIP	90°C/W
14-Pin Molded DIP	85°C/W
14-Pin SO	115°C/W
14-Pin Side Brazed Ceramic DIP	90°C/W

DC Electrical Characteristics

Unless otherwise specified, all limits guaranteed for $T_J = 25^\circ\text{C}$. **Boldface** limits apply at the temperature extremes. $V^+ = 5\text{V}$, $V^- = 0\text{V}$, $V_{CM} = 1.5\text{V}$, $V_O = 2.5\text{V}$, and $R_L > 1\text{M}$ unless otherwise specified.

Parameter	Conditions	Typ	LPC660AM	LPC660AI	LPC660I	Units
			LPC660AMJ/883	Limit	Limit	
			Limit (Notes 4, 8)	Limit (Note 4)	Limit (Note 4)	
Input Offset Voltage		1	3	3	6	mV
			3.5	3.3	6.3	max
Input Offset Voltage Average Drift		1.3				$\mu\text{V}/^\circ\text{C}$
Input Bias Current		0.002	20			pA
			100	4	4	max
Input Offset Current		0.001	20			pA
			100	2	2	max
Input Resistance		>1				Tera Ω
Common Mode Rejection Ratio	$0\text{V} \leq V_{CM} \leq 12.0\text{V}$ $V^+ = 15\text{V}$	83	70	70	63	dB
			68	68	61	min
Positive Power Supply Rejection Ratio	$5\text{V} \leq V^+ \leq 15\text{V}$	83	70	70	63	dB
			68	68	61	min
Negative Power Supply Rejection Ratio	$0\text{V} \leq V^- \leq -10\text{V}$	94	84	84	74	dB
			82	83	73	min
Input Common Mode Voltage Range	$V^+ = 5\text{V} \text{ \& } 15\text{V}$ For CMRR > 50 dB	-0.4	-0.1	-0.1	-0.1	V
			0	0	0	max
		$V^+ - 1.9$	$V^+ - 2.3$	$V^+ - 2.3$	$V^+ - 2.3$	V
			$V^+ - 2.6$	$V^+ - 2.5$	$V^+ - 2.5$	min
Large Signal Voltage Gain	$R_L = 100\text{ k}\Omega$ (Note 5) Sourcing	1000	400	400	300	V/mV
			250	300	200	min
	$R_L = 100\text{ k}\Omega$ (Note 5) Sinking	500	180	180	90	V/mV
			70	120	70	min
$R_L = 5\text{ k}\Omega$ (Note 5) Sourcing	1000	200	200	100	V/mV	
		150	160	80	min	
$R_L = 5\text{ k}\Omega$ (Note 5) Sinking	250	100	100	50	V/mV	
		35	60	40	min	

DC Electrical Characteristics (Continued)

Unless otherwise specified, all limits guaranteed for $T_J = 25^\circ\text{C}$. **Boldface** limits apply at the temperature extremes. $V^+ = 5\text{V}$, $V^- = 0\text{V}$, $V_{\text{CM}} = 1.5\text{V}$, $V_{\text{O}} = 2.5\text{V}$, and $R_L > 1\text{M}$ unless otherwise specified.

Parameter	Conditions	Typ	LPC660AM	LPC660AI	LPC660I	Units	
			LPC660AMJ/883	Limit	Limit		Limit
			(Notes 4, 8)	(Note 4)	(Note 4)		
Output Swing	$V^+ = 5\text{V}$ $R_L = 100\text{ k}\Omega$ to $V^+/2$	4.987	4.970	4.970	4.940	V	
			4.950	4.950	4.910	min	
		0.004	0.030	0.030	0.060	V	
			0.050	0.050	0.090	max	
		$V^+ = 5\text{V}$ $R_L = 5\text{ k}\Omega$ to $V^+/2$	4.940	4.850	4.850	4.750	V
				4.750	4.750	4.650	min
	0.040	0.150	0.150	0.250	V		
		0.250	0.250	0.350	max		
	$V^+ = 15\text{V}$ $R_L = 100\text{ k}\Omega$ to $V^+/2$	14.970	14.920	14.920	14.880	V	
			14.880	14.880	14.820	min	
		0.007	0.030	0.030	0.060	V	
			0.050	0.050	0.090	max	
$V^+ = 15\text{V}$ $R_L = 5\text{ k}\Omega$ to $V^+/2$	14.840	14.680	14.680	14.580	V		
		14.600	14.600	14.480	min		
	0.110	0.220	0.220	0.320	V		
			0.300	0.300	0.400	max	
Output Current $V^+ = 5\text{V}$	Sourcing, $V_{\text{O}} = 0\text{V}$	22	16	16	13	mA	
			12	14	11	min	
	Sinking, $V_{\text{O}} = 5\text{V}$	21	16	16	13	mA	
			12	14	11	min	
Output Current $V^+ = 15\text{V}$	Sourcing, $V_{\text{O}} = 0\text{V}$	40	19	28	23	mA	
			19	25	20	min	
	Sinking, $V_{\text{O}} = 13\text{V}$ (Note 11)	39	19	28	23	mA	
			19	24	19	min	
Supply Current	All Four Amplifiers $V_{\text{O}} = 1.5\text{V}$	160	200	200	240	μA	
			250	230	270	max	

AC Electrical Characteristics

Unless otherwise specified, all limits guaranteed for $T_J = 25^\circ\text{C}$. **Boldface** limits apply at the temperature extremes. $V^+ = 5\text{V}$, $V^- = 0\text{V}$, $V_{\text{CM}} = 1.5\text{V}$, $V_O = 2.5$, and $R_L > 1\text{M}$ unless otherwise specified.

Parameter	Conditions	Typ	LPC660AM	LPC660AI	LPC660I	Units
			LPC660AMJ/883	Limit	Limit	
			Limit (Notes 4, 8)	Limit (Note 4)	Limit (Note 4)	
Slew Rate	(Note 6)	0.11	0.07	0.07	0.05	V/ μs min
			0.04	0.05	0.03	
Gain-Bandwidth Product		0.35				MHz
Phase Margin		50				Deg
Gain Margin		17				dB
Amp-to-Amp Isolation	(Note 7)	130				dB
Input Referred Voltage Noise	F = 1 kHz	42				nV/ $\sqrt{\text{Hz}}$
Input Referred Current Noise	F = 1 kHz	0.0002				pA/ $\sqrt{\text{Hz}}$
Total Harmonic Distortion	F = 1 kHz, $A_V = -10$ $R_L = 100\text{ k}\Omega$, $V_O = 8\text{ V}_{\text{PP}}$	0.01				%

Note 1: Applies to both single supply and split supply operation. Continuous short circuit operation at elevated ambient temperature and/or multiple Op Amp shorts can result in exceeding the maximum allowed junction temperature of 150°C . Output currents in excess of $\pm 30\text{ mA}$ over long term may adversely affect reliability.

Note 2: The maximum power dissipation is a function of $T_{\text{J(max)}}$, θ_{JA} and T_A . The maximum allowable power dissipation at any ambient temperature is $P_D = (T_{\text{J(max)}} - T_A) / \theta_{\text{JA}}$.

Note 3: Absolute Maximum Ratings indicate limits beyond which damage to the device may occur. Operating Ratings indicate conditions for which the device is intended to be functional, but do not guarantee specific performance limits. For guaranteed specifications and test conditions, see the Electrical Characteristics. The guaranteed specifications apply only for the test conditions listed.

Note 4: Limits are guaranteed by testing or correlation.

Note 5: $V^+ = 15\text{V}$, $V_{\text{CM}} = 7.5\text{V}$ and R_L connected to 7.5V . For Sourcing tests, $7.5\text{V} \leq V_O \leq 11.5\text{V}$. For Sinking tests, $2.5\text{V} \leq V_O \leq 7.5\text{V}$.

Note 6: $V^+ = 15\text{V}$. Connected as Voltage Follower with 10V step input. Number specified is the slower of the positive and negative slew rates.

Note 7: Input referred. $V^+ = 15\text{V}$ and $R_L = 100\text{ k}\Omega$ connected to $V^+/2$. Each amp excited in turn with 1 kHz to produce $V_O = 13\text{ V}_{\text{PP}}$.

Note 8: A military RETS electrical test specification is available on request. At the time of printing, the LPC660AMJ/883 RETS specification complied fully with the **boldface** limits in this column. The LPC660AMJ/883 may also be procured to a Standard Military Drawing specification.

Note 9: For operating at elevated temperatures, the device must be derated based on the thermal resistance θ_{JA} with $P_D = (T_J - T_A) / \theta_{\text{JA}}$.

Note 10: All numbers apply for packages soldered directly into a PC board.

Note 11: Do not connect output to V^+ when V^+ is greater than 13V or reliability may be adversely affected.

Typical Performance Characteristics $V_S = \pm 7.5\text{V}$, $T_A = 25^\circ\text{C}$ unless otherwise specified

Supply Current vs Supply Voltage

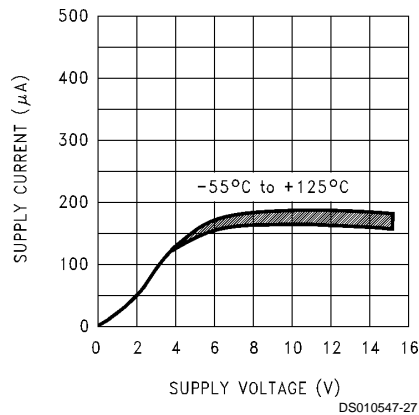

Input Bias Current vs Temperature

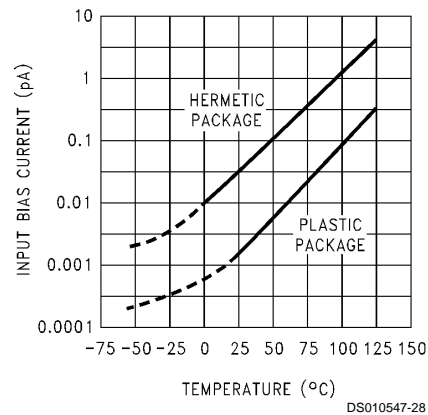

Typical Performance Characteristics $V_S = \pm 7.5V$, $T_A = 25^\circ C$ unless otherwise specified (Continued)

Common-Mode Voltage Range vs Temperature

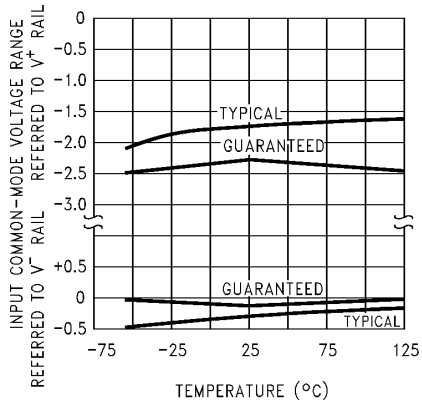

Output Characteristics Current Sinking

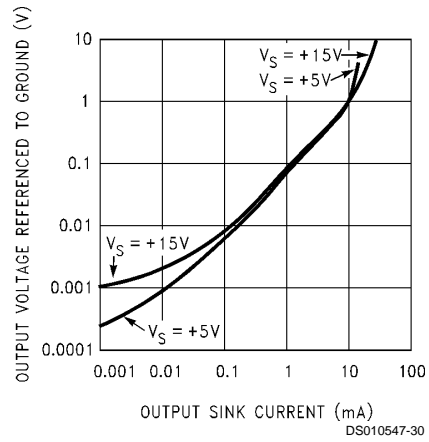

Output Characteristics Current Sourcing

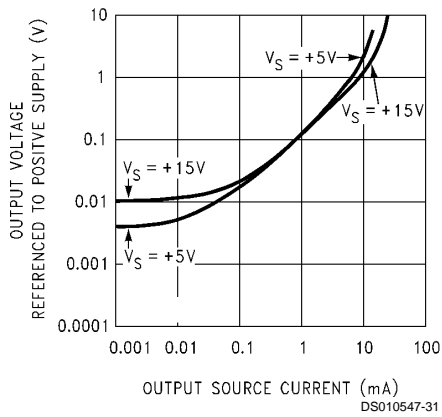

Input Voltage Noise vs Frequency

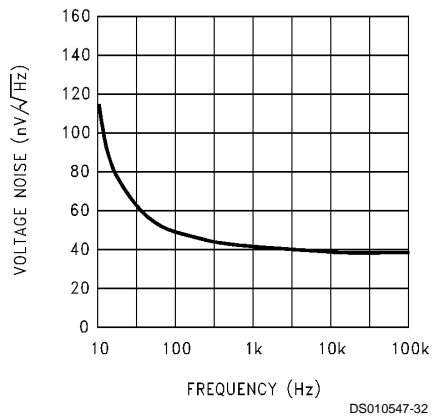

Crosstalk Rejection vs Frequency

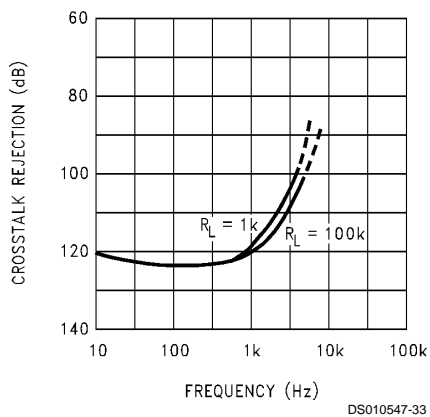

CMRR vs Frequency

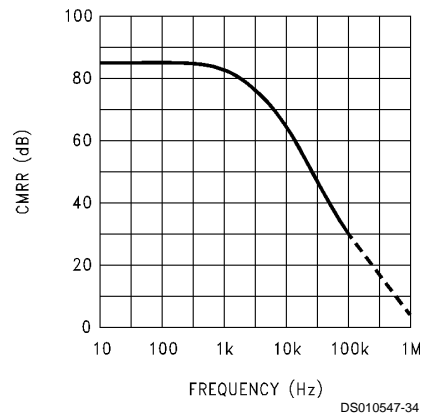

Typical Performance Characteristics $V_S = \pm 7.5V, T_A = 25^\circ C$ unless otherwise specified (Continued)

CMRR vs Temperature

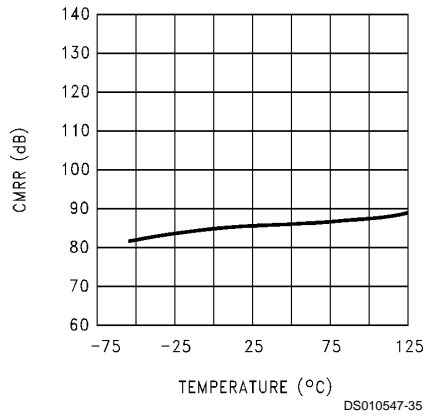

Power Supply Rejection Ratio vs Frequency

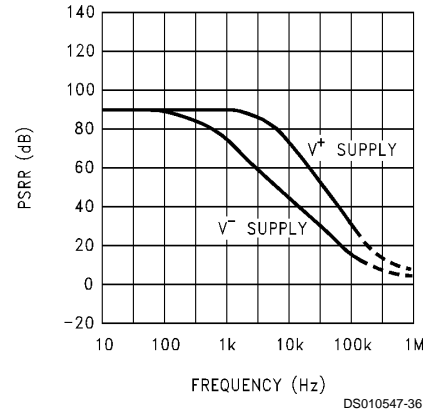

Open-Loop Voltage Gain vs Temperature

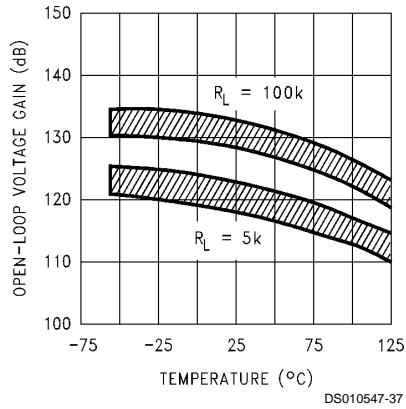

Open-Loop Frequency Response

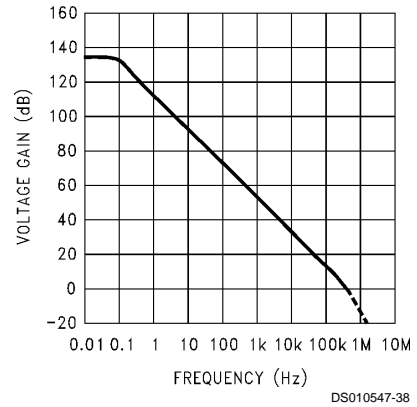

Gain and Phase Responses vs Load Capacitance

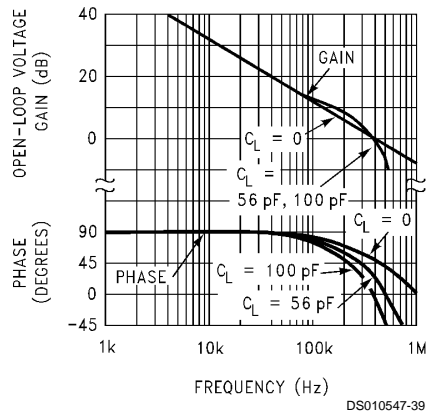

Gain and Phase Responses vs Temperature

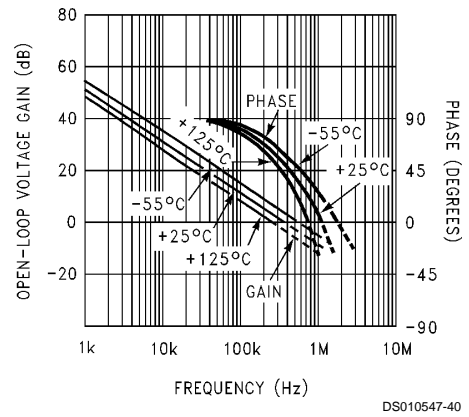

Typical Performance Characteristics $V_S = \pm 7.5V$, $T_A = 25^\circ C$ unless otherwise specified (Continued)

Gain Error
(V_{OS} vs V_{OUT})

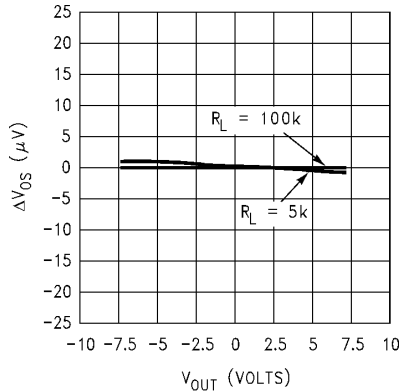

Non-Inverting Slew Rate
vs Temperature

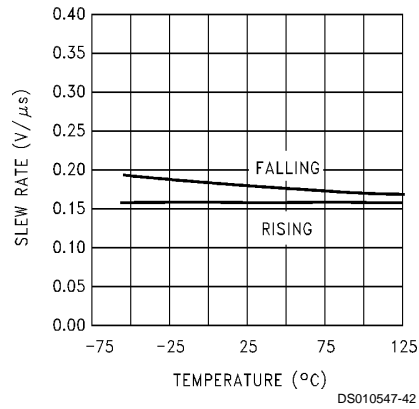

Inverting Slew Rate
vs Temperature

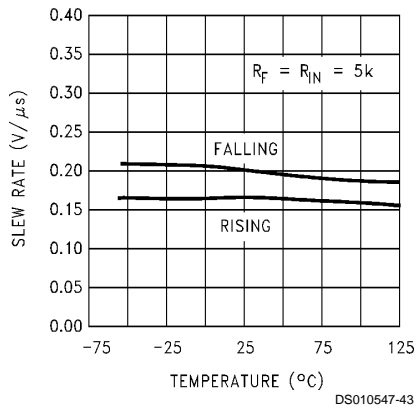

Large-Signal Pulse
Non-Inverting Response
($A_V = +1$)

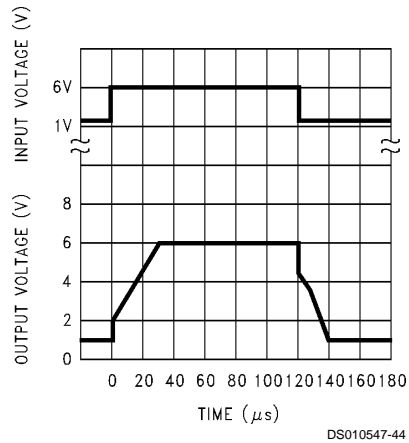

Non-Inverting Small
Signal Pulse Response
($A_V = +1$)

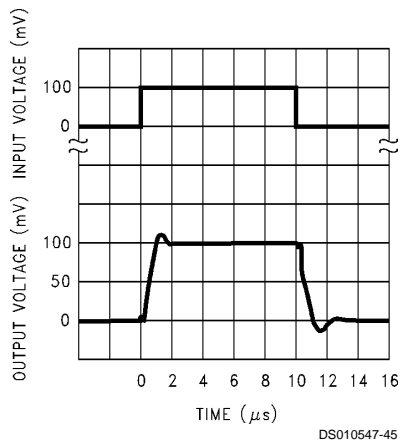

Typical Performance Characteristics $V_S = \pm 7.5V$, $T_A = 25^\circ C$ unless otherwise specified (Continued)

Inverting Large-Signal Pulse Response

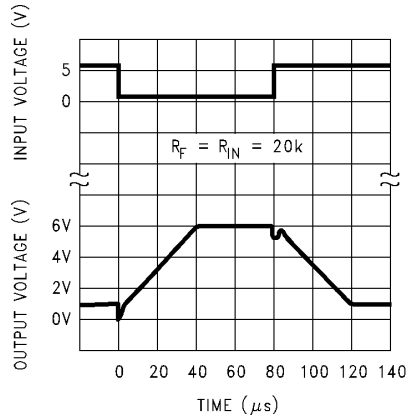

Inverting Small-Signal Pulse Response

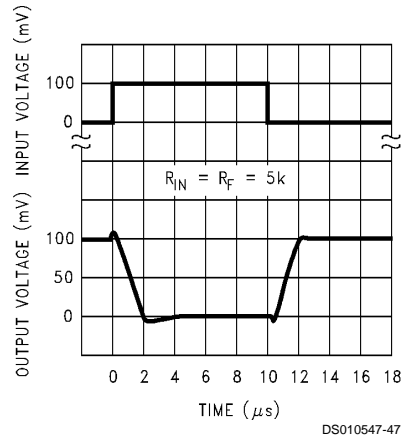

Stability vs Capacitive Load

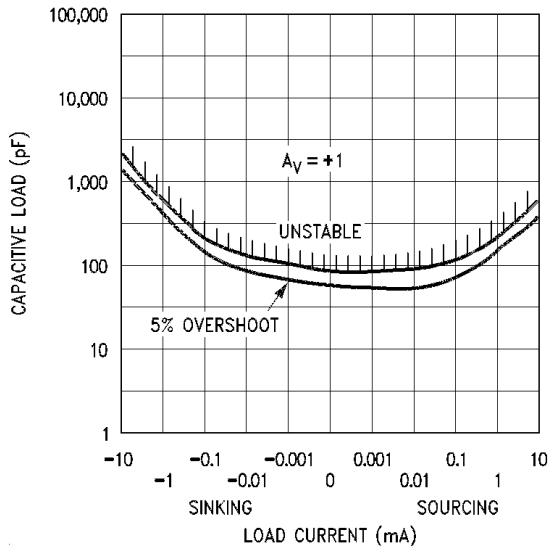

Stability vs Capacitive Load

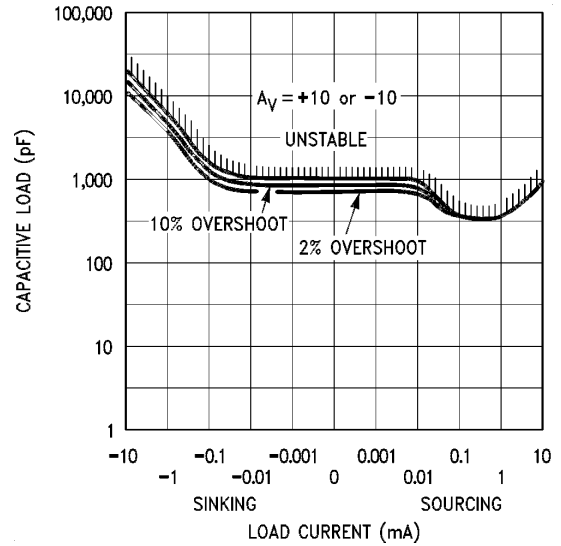

Note: Avoid resistive loads of less than 500Ω , as they may cause instability.

Application Hints

AMPLIFIER TOPOLOGY

The topology chosen for the LPC660 is unconventional (compared to general-purpose op amps) in that the traditional unity-gain buffer output stage is not used; instead, the output is taken directly from the output of the integrator, to allow rail-to-rail output swing. Since the buffer traditionally delivers the power to the load, while maintaining high op amp gain and stability, and must withstand shorts to either rail, these tasks now fall to the integrator.

As a result of these demands, the integrator is a compound affair with an embedded gain stage that is doubly fed forward (via C_f and C_{ff}) by a dedicated unity-gain compensation driver. In addition, the output portion of the integrator is a push-pull configuration for delivering heavy loads. While sinking current the whole amplifier path consists of three gain stages with one stage fed forward, whereas while sourcing the path contains four gain stages with two fed forward.

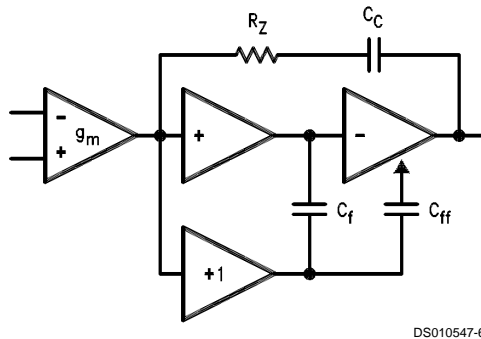

FIGURE 1. LPC660 Circuit Topology (Each Amplifier)

The large signal voltage gain while sourcing is comparable to traditional bipolar op amps, for load resistance of at least 5 k Ω . The gain while sinking is higher than most CMOS op amps, due to the additional gain stage; however, when driving load resistance of 5 k Ω or less, the gain will be reduced as indicated in the Electrical Characteristics. The op amp can drive load resistance as low as 500 Ω without instability.

COMPENSATING INPUT CAPACITANCE

Refer to the LMC660 or LMC662 datasheets to determine whether or not a feedback capacitor will be necessary for compensation and what the value of that capacitor would be.

CAPACITIVE LOAD TOLERANCE

Like many other op amps, the LPC660 may oscillate when its applied load appears capacitive. The threshold of oscillation varies both with load and circuit gain. The configuration most sensitive to oscillation is a unity-gain follower. See the Typical Performance Characteristics.

The load capacitance interacts with the op amp's output resistance to create an additional pole. If this pole frequency is sufficiently low, it will degrade the op amp's phase margin so that the amplifier is no longer stable at low gains. The addition of a small resistor (50 Ω to 100 Ω) in series with the op amp's output, and a capacitor (5 pF to 10 pF) from inverting input to output pins, returns the phase margin to a safe value without interfering with lower-frequency circuit operation. Thus, larger values of capacitance can be

tolerated without oscillation. Note that in all cases, the output will ring heavily when the load capacitance is near the threshold for oscillation.

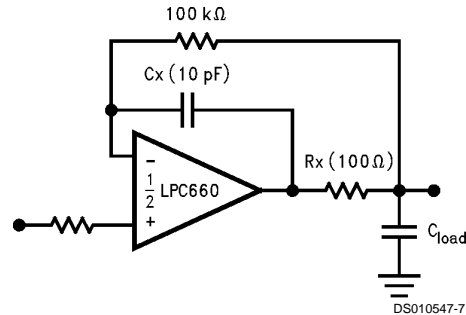

FIGURE 2. Rx, Cx Improve Capacitive Load Tolerance

Capacitive load driving capability is enhanced by using a pull up resistor to V^+ (Figure 3). Typically a pull up resistor conducting 50 μ A or more will significantly improve capacitive load responses. The value of the pull up resistor must be determined based on the current sinking capability of the amplifier with respect to the desired output swing. Open loop gain of the amplifier can also be affected by the pull up resistor (see Electrical Characteristics).

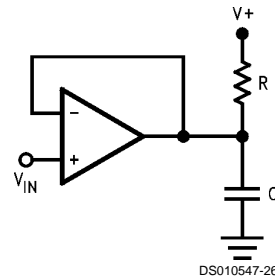

FIGURE 3. Compensating for Large Capacitive Loads with A Pull Up Resistor

PRINTED-CIRCUIT-BOARD LAYOUT FOR HIGH-IMPEDANCE WORK

It is generally recognized that any circuit which must operate with less than 1000 pA of leakage current requires special layout of the PC board. When one wishes to take advantage of the ultra-low bias current of the LPC660, typically less than 0.04 pA, it is essential to have an excellent layout. Fortunately, the techniques for obtaining low leakages are quite simple. First, the user must not ignore the surface leakage of the PC board, even though it may sometimes appear acceptably low, because under conditions of high humidity or dust or contamination, the surface leakage will be appreciable.

To minimize the effect of any surface leakage, lay out a ring of foil completely surrounding the LPC660's inputs and the terminals of capacitors, diodes, conductors, resistors, relay terminals, etc. connected to the op-amp's inputs. See Figure 4. To have a significant effect, guard rings should be placed on both the top and bottom of the PC board. This PC foil must then be connected to a voltage which is at the same voltage as the amplifier inputs, since no leakage current can flow between two points at the same potential. For example, a PC board trace-to-pad resistance of 10^{12} ohms, which is normally considered a very large resistance, could leak 5 pA if the trace were a 5V bus adjacent to the pad of an input.

Application Hints (Continued)

This would cause a 100 times degradation from the LPC660's actual performance. However, if a guard ring is held within 5 mV of the inputs, then even a resistance of 10^{11} ohms would cause only 0.05 pA of leakage current, or perhaps a minor (2:1) degradation of the amplifier's

performance. See *Figure 5a*, *Figure 5b*, *Figure 5c* for typical connections of guard rings for standard op-amp configurations. If both inputs are active and at high impedance, the guard can be tied to ground and still provide some protection; see *Figure 5d*.

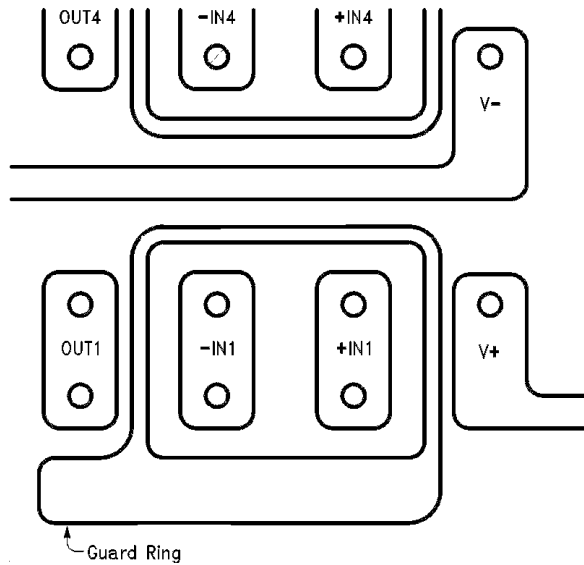

DS010547-19

FIGURE 4. Example of Guard Ring in P.C. Board Layout using the LPC660

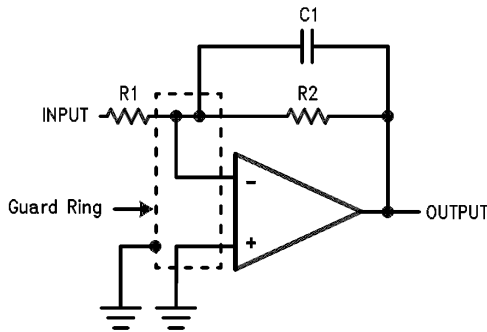

DS010547-20

(a) Inverting Amplifier

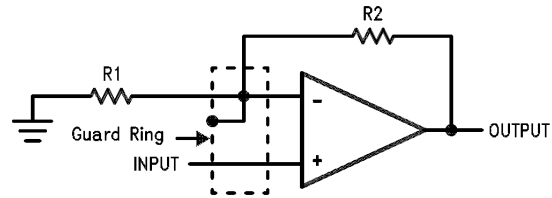

DS010547-21

(b) Non-Inverting Amplifier

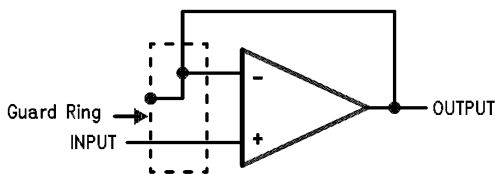

DS010547-22

(c) Follower

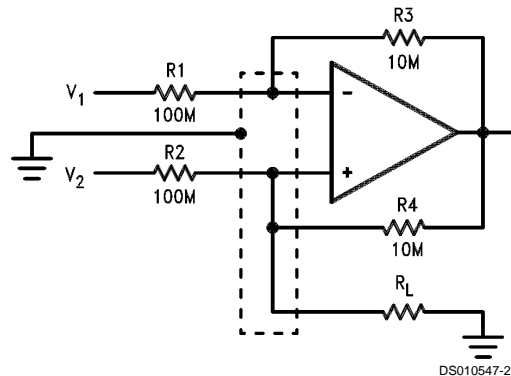

DS010547-23

(d) Howland Current Pump

FIGURE 5. Guard Ring Connections

The designer should be aware that when it is inappropriate to lay out a PC board for the sake of just a few circuits, there

is another technique which is even better than a guard ring on a PC board: Don't insert the amplifier's input pin into the

Application Hints (Continued)

board at all, but bend it up in the air and use only air as an insulator. Air is an excellent insulator. In this case you may have to forego some of the advantages of PC board construction, but the advantages are sometimes well worth the effort of using point-to-point up-in-the-air wiring. See *Figure 6*.

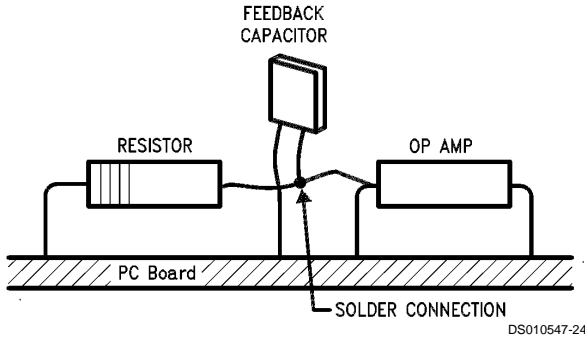

(Input pins are lifted out of PC board and soldered directly to components. All other pins connected to PC board.)

FIGURE 6. Air Wiring

BIAS CURRENT TESTING

The test method of *Figure 7* is appropriate for bench-testing bias current with reasonable accuracy. To understand its operation, first close switch S2 momentarily. When S2 is opened, then

$$I^- = \frac{dV_{OUT}}{dt} \times C2.$$

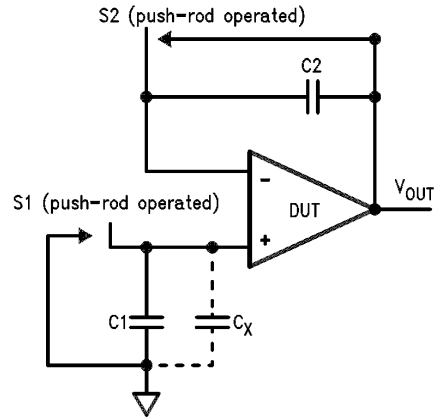

FIGURE 7. Simple Input Bias Current Test Circuit

A suitable capacitor for C2 would be a 5 pF or 10 pF silver mica, NPO ceramic, or air-dielectric. When determining the magnitude of I^- , the leakage of the capacitor and socket must be taken into account. Switch S2 should be left shorted most of the time, or else the dielectric absorption of the capacitor C2 could cause errors.

Similarly, if S1 is shorted momentarily (while leaving S2 shorted)

$$I^+ = \frac{dV_{OUT}}{dt} \times (C1 + C_x)$$

where C_x is the stray capacitance at the + input.

Typical Single-Supply Applications ($V^+ = 5.0 V_{DC}$)

Photodiode Current-to-Voltage Converter

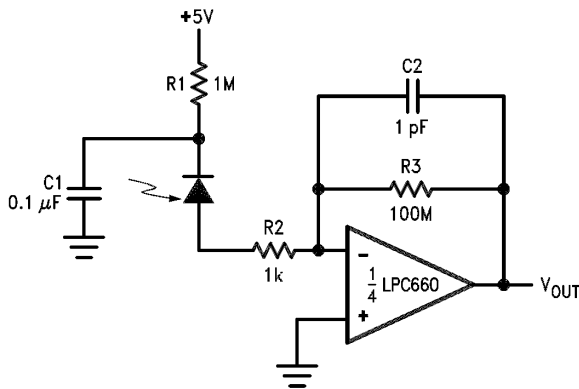

Note: A 5V bias on the photodiode can cut its capacitance by a factor of 2 or 3, leading to improved response and lower noise. However, this bias on the photodiode will cause photodiode leakage (also known as its dark current).

Micropower Current Source

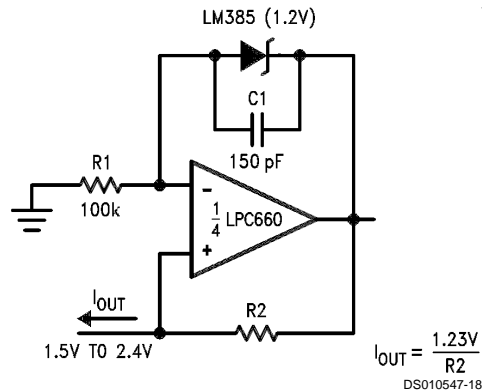

Note: (Upper limit of output range dictated by input common-mode range; lower limit dictated by minimum current requirement of LM385.)

Typical Single-Supply Applications $(V^+ = 5.0 V_{DC})$ (Continued)

Low-Leakage Sample-and-Hold

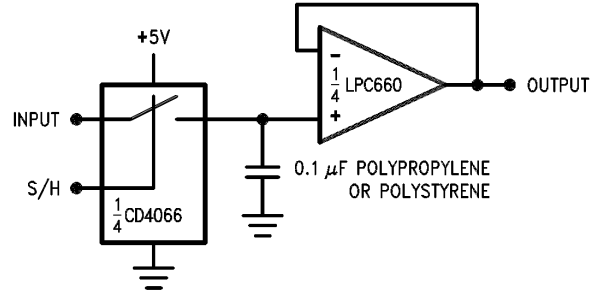

DS010547-8

Instrumentation Amplifier

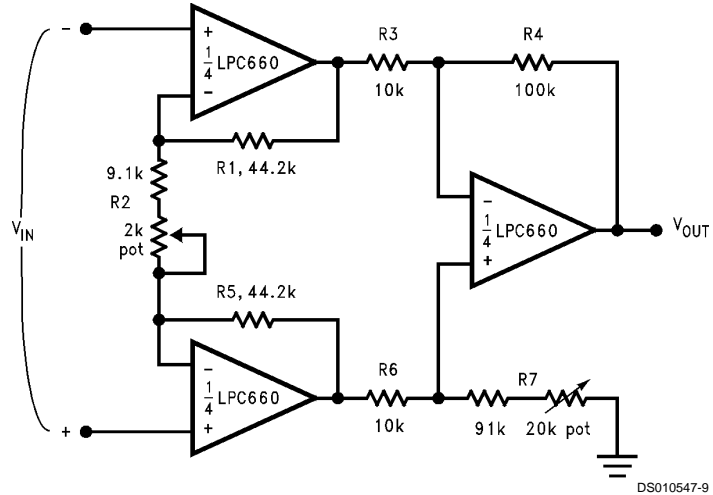

DS010547-9

If $R1 = R5$, $R3 = R6$, and $R4 = R7$;

$$\text{then } \frac{V_{OUT}}{V_{IN}} = \frac{R2 + 2R1}{R1} \times \frac{R4}{R3}$$

$\therefore A_V \approx 100$ for circuits shown.

For good CMRR over temperature, low drift resistors should be used. Matching of $R3$ to $R6$ and $R4$ to $R7$ affects CMRR. Gain may be adjusted through $R2$. CMRR may be adjusted through $R7$.

Typical Single-Supply Applications ($V^+ = 5.0 V_{DC}$) (Continued)

Sine-Wave Oscillator

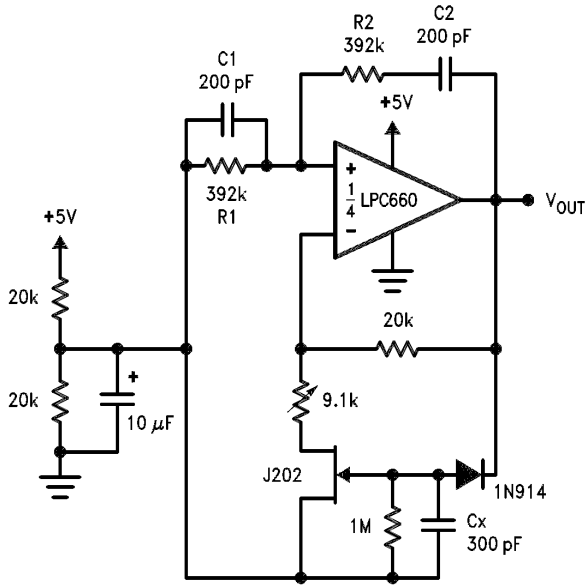

DS010547-10

Oscillator frequency is determined by R1, R2, C1, and C2:

$$f_{OSC} = 1/2\pi RC$$

where $R = R1 = R2$ and $C = C1 = C2$.

This circuit, as shown, oscillates at 2.0 kHz with a peak-to-peak output swing of 4.5V

1 Hz Square-Wave Oscillator

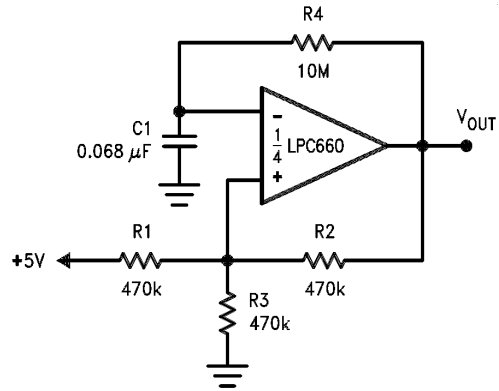

DS010547-11

Power Amplifier

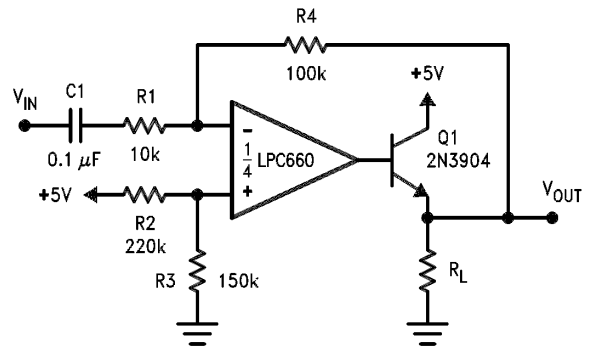

DS010547-12

Typical Single-Supply Applications $(V^+ = 5.0 V_{DC})$ (Continued)

10 Hz Bandpass Filter

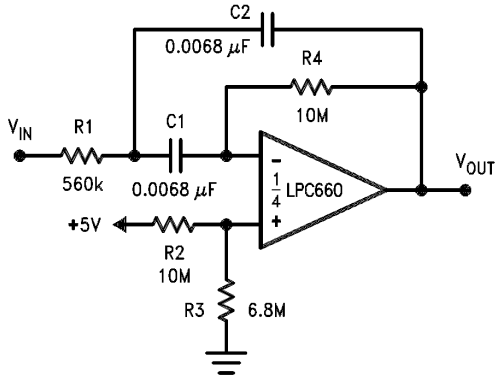

DS010547-13

$f_0 = 10 \text{ Hz}$
 $Q = 2.1$
 Gain = -8.8

10 Hz High-Pass Filter (2 dB Dip)

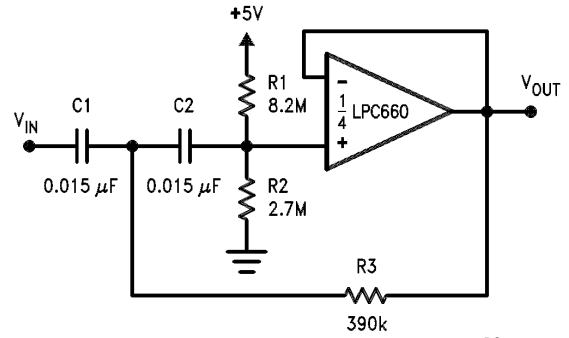

DS010547-14

$f_c = 10 \text{ Hz}$
 $d = 0.895$
 Gain = 1

1 Hz Low-Pass Filter
 (Maximally Flat, Dual Supply Only)

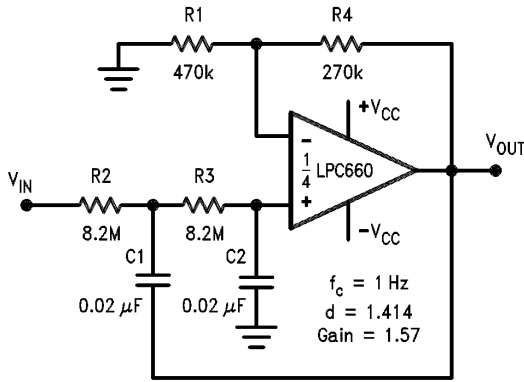

DS010547-15

$f_c = 1 \text{ Hz}$
 $d = 1.414$
 Gain = 1.57

High Gain Amplifier with Offset Voltage Reduction

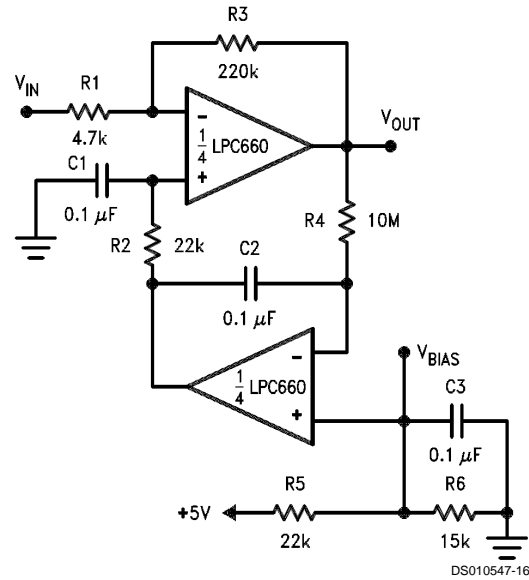

DS010547-16

Gain = -46.8
 Output offset voltage reduced to the level of the input offset voltage of the bottom amplifier (typically 1 mV), referred to V_{BIAS} .

Connection Diagram

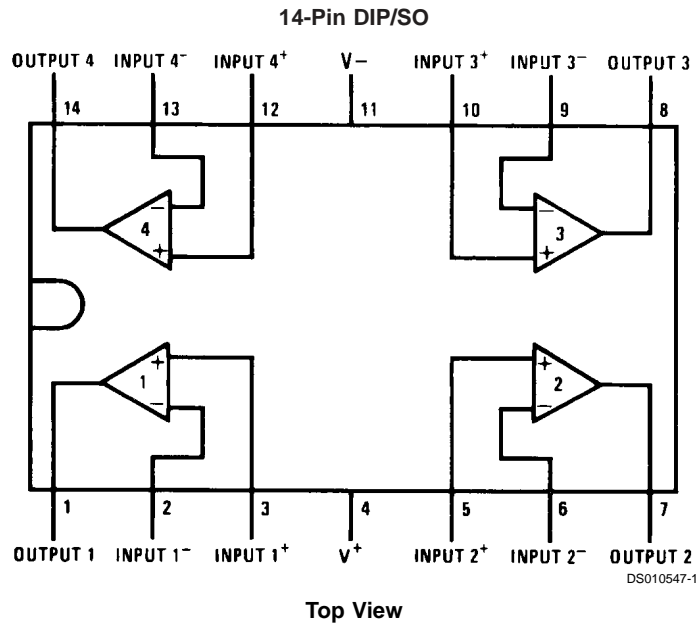

Ordering Information

Package	Temperature Range		NSC Drawing	Transport Media
	Military	Industrial		
14-Pin Side Brazed Ceramic DIP	LPC660AMD		D14E	Rail
14-Pin Small Outline		LPC660AIM or LPC660IM	M14A	Rail Tape and Reel
14-Pin Molded DIP		LPC660AIN or LPC660IN	N14A	Rail
14-Pin Ceramic DIP	LPC660AMJ/883		J14A	Rail

Physical Dimensions inches (millimeters) unless otherwise noted

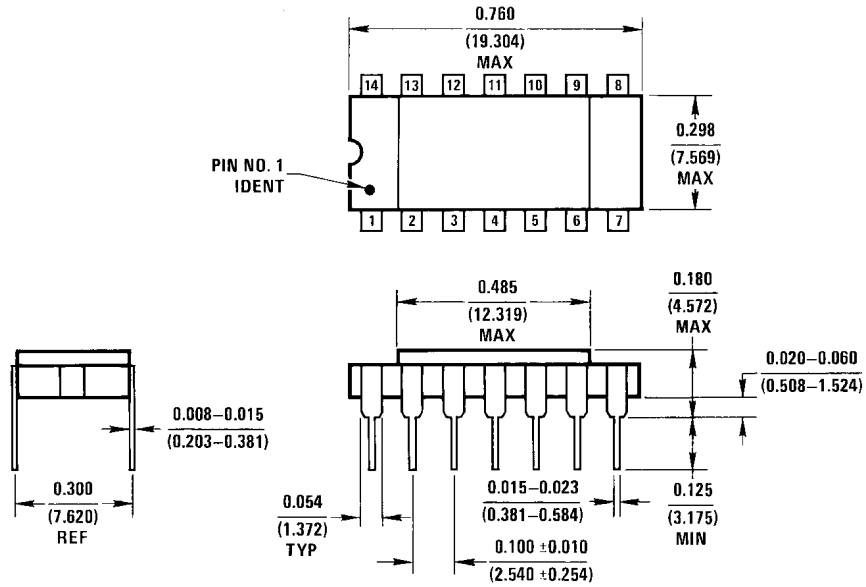

D14E (REV E)

14-Pin Cavity Dual-In-Line Package (D)
Order Number LPC660AMD
NS Package Number D14E

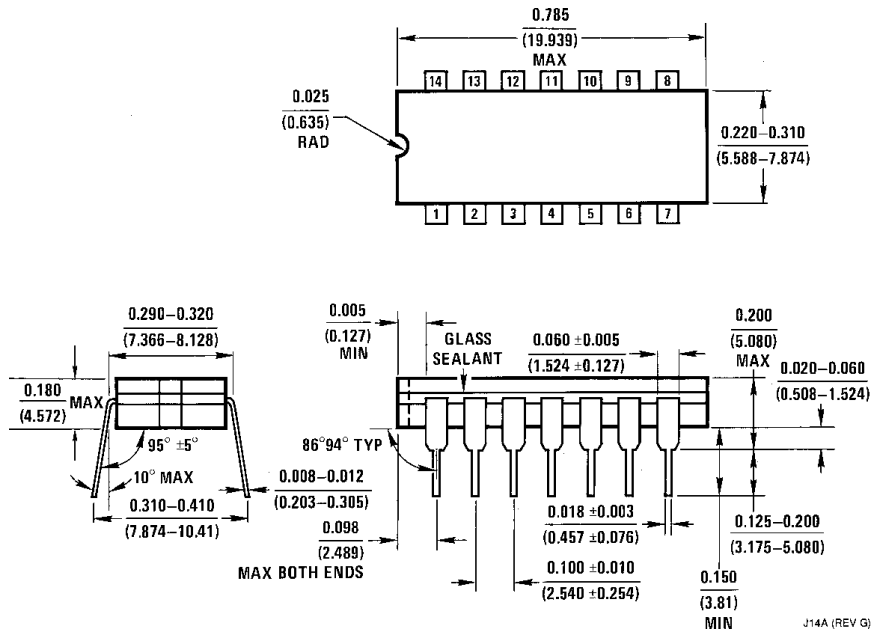

J14A (REV G)

14-Lead Ceramic Dual-In-Line Package (J)
Order Number LPC660AMJ/883
NS Package Number J14A

Physical Dimensions inches (millimeters) unless otherwise noted (Continued)

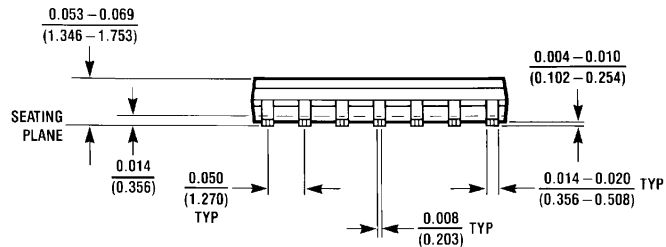
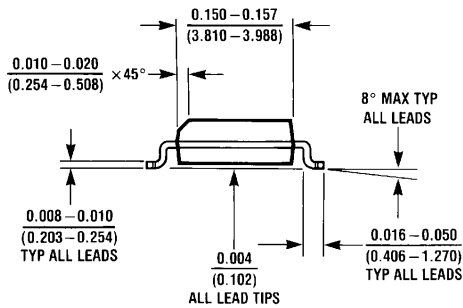
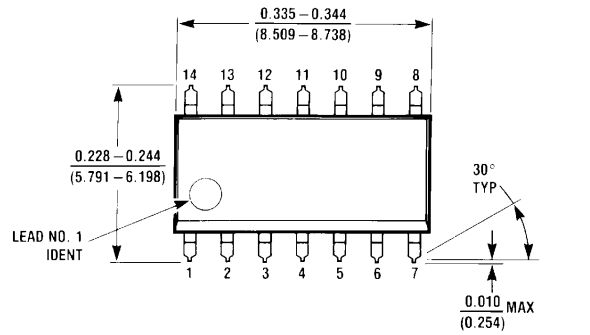

M14A (REV H)

14-Pin Small Outline Molded Package (M)
Order Number LPC660AIM or LPC660IM
NS Package Number M14A

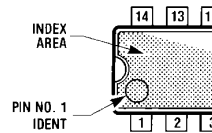
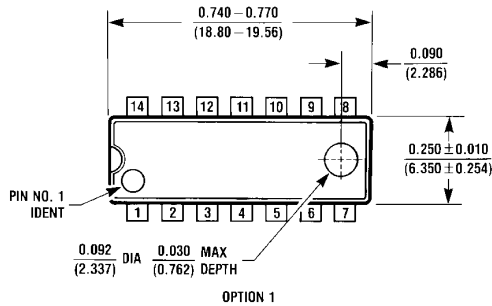

OPTION 1

OPTION 02

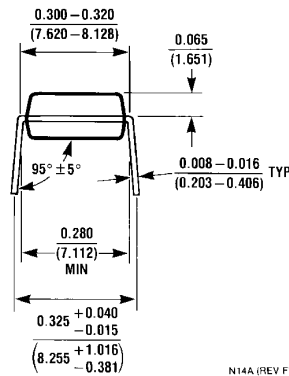
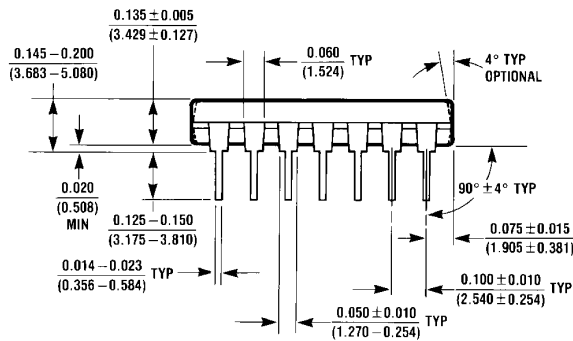

N14A (REV F)

14-Pin Molded Dual-In-Line Package (N)
Order Number LPC660AIN or LPC660IN
NS Package Number N14A

Notes

LIFE SUPPORT POLICY

NATIONAL'S PRODUCTS ARE NOT AUTHORIZED FOR USE AS CRITICAL COMPONENTS IN LIFE SUPPORT DEVICES OR SYSTEMS WITHOUT THE EXPRESS WRITTEN APPROVAL OF THE PRESIDENT AND GENERAL COUNSEL OF NATIONAL SEMICONDUCTOR CORPORATION. As used herein:

1. Life support devices or systems are devices or systems which, (a) are intended for surgical implant into the body, or (b) support or sustain life, and whose failure to perform when properly used in accordance with instructions for use provided in the labeling, can be reasonably expected to result in a significant injury to the user.
2. A critical component is any component of a life support device or system whose failure to perform can be reasonably expected to cause the failure of the life support device or system, or to affect its safety or effectiveness.



National Semiconductor Corporation
Americas
Tel: 1-800-272-9959
Fax: 1-800-737-7018
Email: support@nsc.com
www.national.com

National Semiconductor Europe
Fax: +49 (0) 180-530 85 86
Email: europe.support@nsc.com
Deutsch Tel: +49 (0) 69 9508 6208
English Tel: +44 (0) 870 24 0 2171
Français Tel: +33 (0) 1 41 91 8790

National Semiconductor Asia Pacific Customer Response Group
Tel: 65-2544466
Fax: 65-2504466
Email: ap.support@nsc.com

National Semiconductor Japan Ltd.
Tel: 81-3-5639-7560
Fax: 81-3-5639-7507

See A/D Converters Products

[Products](#) > [Analog - Amplifiers](#) > [Operational Amplifiers](#) > [Low Power](#) > LPC660

LPC660 Product Folder

Low Power CMOS Quad Operational Amplifier

[General Description](#)

[Features](#)

[Datasheet](#)

[Package & Models](#)

[Samples & Pricing](#)

[Design Tools](#)

[Application Notes](#)

Parametric Table

Channels (Channels)	4
Input Output Type	Vcm to V-, R-R Out
Bandwidth, typ (MHz)	.35
Slew Rate, typ (Volts/usec)	.11
Supply Current per Channel, typ (mA)	.04
Minimum Supply Voltage (Volt)	5

Parametric Table

Maximum Supply Voltage (Volt)	15
Offset Voltage, Max (mV)	3, 6
Input Bias Current, Temp Max (nA)	.0040
Output Current, typ (mA)	21
Voltage Noise, typ (nV/Hz)	42
Shut down	No
Special Features	-

Datasheet

Title	Size in Kbytes	Date	<input type="checkbox"/> View Online	<input type="checkbox"/> Download	<input type="checkbox"/> Receive via Email
LPC660 Low Power CMOS Quad Operational Amplifier	625 Kbytes	7-Mar-01	View Online	Download	Receive via Email
LPC660 Low Power CMOS Quad Operational Amplifier (JAPANESE)	475 Kbytes		<input type="checkbox"/> View Online	<input type="checkbox"/> Download	<input type="checkbox"/> Receive via

If you have trouble printing or viewing PDF file(s), see [Printing Problems](#).

Package Availability, Models, Samples & Pricing

Part Number	Package			Status	Models		Samples & Electronic Orders	Budgetary Pricing		Std Pack Size	Package Marking
	Type	Pins	MSL		SPICE	IBIS		Qty	\$US each		
LPC660AIM	SOIC NARROW	14	MSL	Full production	LPC660A.MOD	N/A	<input type="checkbox"/> Samples <input type="checkbox"/> Buy Now	1K+	\$1.5000	rail of 55	[logo]UçZç2çT LPC660AIM

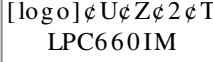
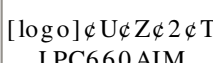
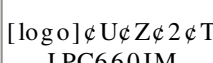
LPC660IM	SOIC NARROW	14	MSL	Full production	N/A	N/A	24 Hour Buy Now	1K+	\$1.2000	rail of 55	 [logo] UçZç2çT LPC660IM
LPC660AIMX	SOIC NARROW	14	MSL	Full production	LPC660A.MOD	N/A	Buy Now	1K+	\$1.5000	reel of 2500	 [logo] UçZç2çT LPC660AIM
LPC660IMX	SOIC NARROW	14	MSL	Full production	N/A	N/A	Buy Now	1K+	\$1.2000	reel of 2500	 [logo] UçZç2çT LPC660IM
LPC660 MDC	Die			Full production	N/A	N/A	Samples			tray of N/A	-

General Description

The LPC660 CMOS Quad operational amplifier is ideal for operation from a single supply. It features a wide range of operating voltages from +5V to +15V and features rail-to-rail output swing in addition to an input common-mode range that includes ground. Performance limitations that have plagued CMOS amplifiers in the past are not a problem with this design. Input V_{OS} , drift, and broadband noise as well as voltage gain (into 100 k Ω and 5 k Ω) are all equal to or better than widely accepted bipolar equivalents, while the power supply requirement is typically less than 1 mW.

This chip is built with National's advanced Double-Poly Silicon-Gate CMOS process.

See the LPC662 datasheet for a Dual CMOS operational amplifier and LPC661 datasheet for a single CMOS operational amplifier with these same features.

Features

Rail-to-rail output swing	
Micropower operation:	(1 mW)
Specified for 100 k Ω and 5 k Ω loads	
High voltage gain:	120 dB
Low input offset voltage:	3 mV
Low offset voltage drift:	1.3 μ V/ $^{\circ}$ C
Ultra low input bias current:	2 fA
Input common-mode includes V^{-}	
Operation range from +5V to +15V	
Low distortion:	0.01% at 1 kHz
Slew rate:	0.11 V/ μ s
Full military temp. range available	

Applications

- High-impedance buffer
- Precision current-to-voltage converter
- Long-term integrator
- High-impedance preamplifier
- Active filter
- Sample-and-Hold circuit
- Peak detector

Design Tools

Title	Size in Kbytes	Date	<input type="checkbox"/> View Online	<input type="checkbox"/> Download	<input type="checkbox"/> Receive via Email
Amplifiers Selection Guide software for Windows	7 Kbytes	12-Jun-2002	View		

If you have trouble printing or viewing PDF file(s), see [Printing Problems](#).

Application Notes

Title	Size in Kbytes	Date	<input type="checkbox"/> View Online	<input type="checkbox"/> Download	<input type="checkbox"/> Receive via Email
AN-856: A SPICE Compatible Macromodel for CMOS Operational Amplifiers	105 Kbytes	5-Aug-95	View Online	Download	Receive via Email

If you have trouble printing or viewing PDF file(s), see [Printing Problems](#).

[Information as of 5-Aug-2002]

Search

[Design](#)
 [Purchasing](#)
 [Quality](#)
 [Company](#)
 [Home](#)

[About Languages](#) .
 [Website Guide](#) .
 [About "Cookies"](#) .
 National is [QS 9000 Certified](#) .
 [Privacy/Security Statement](#) .
 [Contact Us](#) .
 [Site Terms & Conditions of Use](#) .
 Copyright 2002 © National Semiconductor Corporation .
 [My Preferences](#) .
 [Feedback](#)