

APPROVED: _____
 DATE: _____ TITLE: _____

Rev	AWO #	Description	Date	Appr
-		RELEASED	11/5/20	
A		UPDATE DRAWING.	5/11/21	JJ/RC
B		ADDED DRAWING.	8/9/21	WX/RC

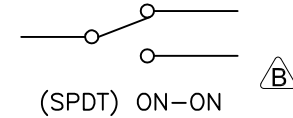
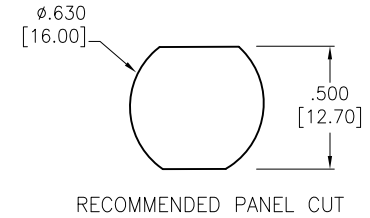
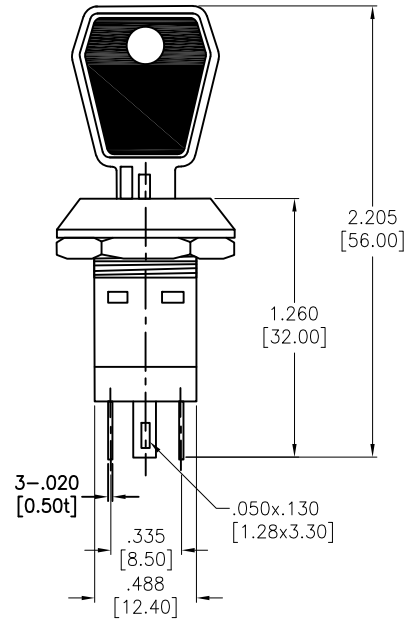
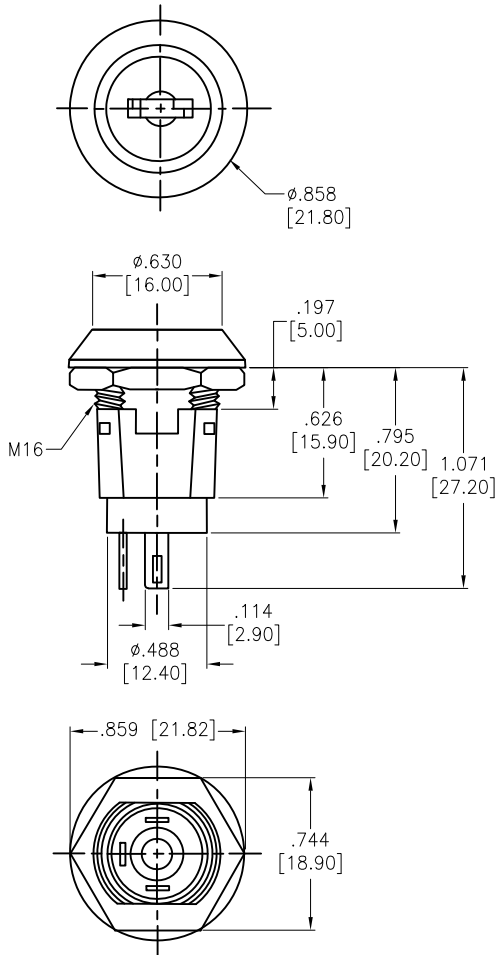

SPECIFICATIONS:

Material:
 Body: Steel, Polished Chrome
 Electrical:
 The rated load: 125 VAC, 2A
 250 VAC, 1A
 28 VDC, 2A
 Contact resistance: 20 m Ω max
 Insulation resistance: 100 M Ω min (500VDC)
 Dielectric withstanding voltage: 1000 VAC for 1 minute
 Mechanical life: \geq 10000 Cycles
 Temperature Rating:
 -20°C to +85°C
 Environmental:
 Lead free, RoHS compliant



ADAM-P/N	SPEC.
SW-R-K8-A	Key pulled on both positions. Note: this would be our standard
SW-R-K8-B	Key pulled on 1 position

UNLESS OTHERWISE SPECIFIED ALL DIMENSIONS ARE INCHES [MM]. TOLERANCES: EXCEPT AS NOTED

INCHES		HOLES	
.x	$\pm .10$	ϕ .x	$\pm .10$
.xx	$\pm .020$	ϕ .xx	$\pm .015$
.xxx	$\pm .015$	ϕ .xxx	$\pm .010$



909 Rahway Avenue,
 Union, NJ 07083
 Phone: 908-687-5000
 Fax: 908-687-5710

DRAWN	OW	11/5/20
CHECKED	AC	11/5/20
APPROVED		

TITLE: SWITCH, KEY LOCK, 16MM, SPDT, ON-ON
 PANEL MOUNT, SOLDER TERMINAL

THIS DRAWING CONTAINS INFORMATION THAT IS PROPRIETARY AND SHOULD NOT BE USED WITHOUT PRIOR WRITTEN PERMISSION FROM ADAM TECH

SIZE X	PART NO. SW-R-K8-X	REV. B
REF: S00206C	SCALE: NTS	SHEET 1 OF 1