

Modulated VLD Laser Pointer

Operator's Manual



Model Number:
ML 268

INDUSTRIAL FIBER OPTICS

*

Copyright © 2014
Previous Printing 2009
by Industrial Fiber Optics, Inc.
Revision - E

Printed in the United States of America

* * *

All rights reserved. No part of this publication may be reproduced,
stored in a retrieval system, or transmitted in any form or by any means
(electronic, mechanical, photocopying, recording, or otherwise)
without prior written permission from Industrial Fiber Optics.

* * * * *

INTRODUCTION

This manual provides information about the ML 268 Video Diode Laser that was formerly manufactured by Metrologic, Inc. It contains all the information needed to set up and operate these lasers safely and knowledgeably, even if you are a novice to laser technology. Please read the manual carefully before operating the laser.

*As soon as you receive this laser, inspect it and the shipping container for damage. If any damage is found, immediately refer to the section of this manual entitled *Shipment Damage Claims*.*

Industrial Fiber Optics makes every effort to incorporate state-of-the-art technology, highest quality and dependability in its products. We constantly explore new ideas and products to best serve the rapidly expanding needs of industry and education. We encourage comments that you may have about our products, and we welcome the opportunity to discuss new ideas that may better serve your needs. For more information about our company and products refer to <http://www.i-fiberoptics.com> on the Worldwide Web.

Thank you for selecting this Industrial Fiber Optics product. We hope it meets your expectations and provides many hours of productive activity.

Sincerely,

The Industrial Fiber Optics Team

TABLE OF CONTENTS

| | |
|---|-----------|
| Introduction..... | i |
| LASER CLASSIFICATIONS..... | iv |
| OPERATING SAFETY..... | 1 |
| LABELS..... | 1 |
| MODULATED LASER POINTER PARTS..... | 2 |
| RECHARGING THE BATTERIES..... | 3 |
| ML268 MICROPHONE AMPLIFIER..... | 4 |
| OPERATING THE LASER POINTER..... | 5 |
| SPECIFICATIONS..... | 6 |
| BENEFITS OF THE ML268..... | 6 |
| SERVICE AND MAINTENANCE..... | 7 |
| WARRANTY..... | 8 |
| SHIPMENT DAMAGE CLAIMS..... | 9 |

LASER CLASSIFICATIONS

All manufacturers of lasers used in the United States must conform to regulations administered by the Center for Devices and Radiological Health (CDRH), a branch of the U.S. Department of Health and Human Services. CDRH categorizes lasers as follows:

| Class | Description |
|-------|--|
| I | A laser or laser system, which does not present a hazard to skin or eyes for any wavelength or exposure time. Exposure varies with wavelength. For ultraviolet, 2 to 4 μm exposures is less than from 8 nW to 8 μW . Visible light exposure varies from 4 μW to 200 μW , and for near-IR, the exposure is < 200 μW . Consult CDRH regulations for specific information. |
| II | Any visible laser with an output less than 1 mW of power. Warning label requirements – yellow caution label stating maximum output of 1 mW. Generally used as classroom lab lasers, supermarket scanners and laser pointers |
| IIIa | Any visible laser with an output over 1 mW of power with a maximum output of 5 mW of power. Warning label requirements – red danger label stating maximum output of 5 mW. Also used as classroom lab lasers, in holography, laser pointers, leveling instruments, measuring devices and alignment equipment. |
| IIIb | Any laser with an output over 5 mW of power with a maximum output of 500 mW of power and all invisible lasers with an output up to 400 mW. Warning label requirements – red danger label stating maximum output. These lasers also require a key switch for operation and a 3.5-second delay when the laser is turned on. Used in many of the same applications as the Class IIIa when more power is required. |
| IV | Any laser with an output over 500 mW of power. Warning label requirements – red danger label stating maximum output. These lasers are primarily used in industrial applications such as tooling, machining, cutting and welding. Most medical laser applications also require these high-powered lasers. |

OPERATING SAFETY

The laser pointer is a low powered laser. Like all Industrial Fiber Optics laser pointers, invisible, exotic, or otherwise harmful radiation is not emitted. Though the power of the laser pointer is low, the beam should be treated with caution and common sense because it is intense and concentrated. The greatest potential for harm with the laser pointer is to the eyes. Just as no one should stare at the sun or arc lamps, no one should look directly into the laser beam or stare at its bright reflections. See “Rules for Laser Safety” on the back cover.

The following is a list of other items to consider when using the laser pointer:

- Keep the aperture clean of dust.
- Never poke sharp instruments into the aperture.
- Be careful not to drop the laser or apply excessive pressure to the case.
- Avoid extremes of temperatures.
- Do not immerse the laser pointer in water or other liquids.

Caution:

Using controls, making adjustments, or performing procedures other than those specified herein may result in hazardous radiation exposure.

LABELS

Located on the bottom of the ML 268 laser pointer are the following labels:

Manufactured by Industrial Fiber Optics, Tempe, AZ 85281 **Model No: ML268**
Serial No: xx-xxxx Date Manufactured: Month Year
Voltage 9 Volts DC CAUTION: There are no user serviceable components within the laser housing. Opening of the laser housing voids Industrial Fiber Optics warranty. Conforms to US DHHS Laser Performance Standards and 21 CFR 1040.10 and 1040.11 on the date of manufacture. Made in U.S.A.

1756



MODULATED LASER POINTER PARTS

1. Push - Button Switch

Pressing this switch will activate the laser when the ON/OFF Switch is in the PUSH ON position.

2. Laser Aperture

The laser beam is emitted from this aperture. Never look directly into this hole when the laser beam is on.

3. Shutter

The shutter can block the passage of the laser beam or allow the laser beam to pass through the aperture. To open the shutter, push it in the direction of the white OPEN arrow. Figure 1 shows the shutter in the open position. To close, push the shutter in the opposite direction.

4. DC Input Jack

For operation from an AC power source and for battery charging, an AC adapter/battery charger must be plugged into this jack.

5. ON/OFF Switch

This is a three-position power switch for steady or intermittent use: ON, OFF, PUSH ON. In the ON position, the laser will operate continuously. In the OFF position, the laser will not operate. In the PUSH ON position, the laser will operate only when the push-button switch on the front of the ML268 laser is pressed. The ON/OFF switch does not affect battery charging.

6. Laser Light Emission Indicator

When the ON/OFF switch is in the ON position, as illustrated in Figure 1, a red band is revealed between the OFF and PUSH ON position to indicate that the laser is active.

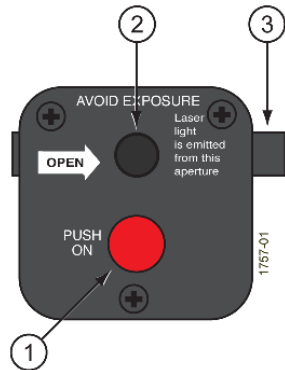

Figure 1. Front view of ML268 laser.

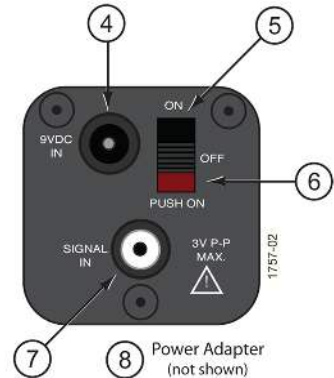

Figure 2. Rear view of ML268 laser.

7. Signal Input Jack

This is a standard RCA-type phono jack. It can accept audio signals from radios as well as CD and MP3 players. It will also accept composite video signals from video cameras, camcorders or video recorders. The modulation bandwidth is sufficient for transmitting color (composite video) signals. The input has an impedance of 75 Ohms and can accept signals up to 3 Volts peak-to-peak.

8. Power Adapter (not shown)

All Industrial Fiber Optics lasers sold in the United States come complete with a power adapter suitable for 60 Hz 110 VAC-to-VDC conversion. When shipped to international regions that are on a 50 Hz 220 VAC power grid, Industrial Fiber Optics will supply 220 VAC to 110 VAC step down transformers to be used in conjunction with the 110 VAC power adapters. It is strongly recommended that the power adapter furnished with the laser be the only supply used.

If you must use another power supply, it must be one with voltage output between 9 to 15 volts DC and minimum current capability of 150 milliamperes. Do not use a power supply which may generate spikes exceeding 36 volts.

RECHARGING THE BATTERIES

Located inside your ML268 laser pointer are four rechargeable nickel-cadmium batteries. The batteries are shipped in a discharged condition. Before operating your laser for the first time, charge the batteries for 14-16 hours with the AC adapter/battery charger included with your purchase of the ML268 laser pointer. When recharging, the ON/OFF switch has no effect. However, if the ON/OFF switch is in the ON position during recharging, the laser beam will be emitted.

1. Plug the AC adapter/battery charger into the DC input jack and a 115 AC outlet.
2. Keep the unit plugged in for 14-16 hours.

NOTE 1: If the unit is operating with the AC adapter/battery charger plugged in, the batteries inside the unit will be continuously charging. Overcharging will result if the laser pointer is left connected to the AC adapter/battery charger and plugged into an AC outlet. Overcharging causes shortened battery life. Therefore, the AC adapter/battery charger should be disconnected from the ML268 laser pointer when the unit is not in use.

NOTE 2: The batteries will hold a charge better after about two charge and discharge cycles.

ML268 MICROPHONE AMPLIFIER

To use a microphone as a source for modulation of the laser, an amplifier with the appropriate connectors is needed. A suitable circuit is shown in Figure 2.

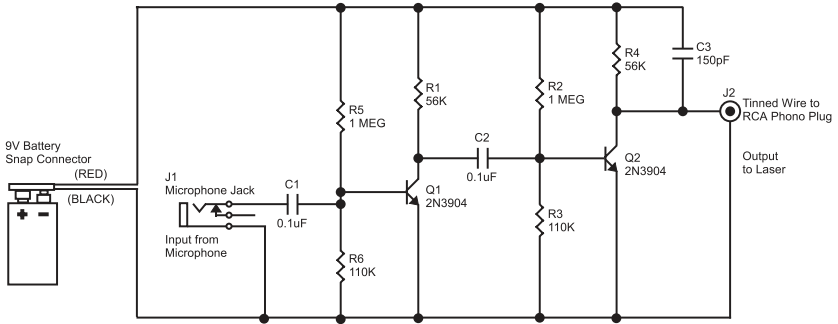

1758

Figure 3. ML268 schematic.

NOTES:

1. Gain may be adjusted by varying the R1 from 10k to 100k.
2. Bandwidth is 20 to 20,000 Hz.
3. Parts list shown in Table 1, or a complete kit of parts is available from INDUSTRIAL FIBER OPTICS, Part Number 45-245.

Table 1. Parts List

| Figure Label | Description | Radio Shack | Mouser Electronics |
|--------------|-------------------|-------------|--------------------|
| | Project Box | 270-283 | N/A |
| BT1 | Battery Clip | 270-326 | 121-0626/I-GR |
| C1, C2 | .1 µF Capacitor | 272-135 | 581-SR215E104 |
| C3 | 150 pF Capacitor | N/A | 80-C410C151J1G |
| J1 | 3.5 mm Mono Jack | N/A | 16PJ012 |
| J2 | RCA Plug | N/A | 172-RPA1201 |
| R1, R4 | 56 kΩ Resistor | N/A | 660-MF1/4DC5602F |
| R2, R5 | 1 MΩ Resistor | N/A | 660-MF1/4DC1004F |
| R3, R6 | 110 kΩ Resistor | N/A | 660-MF1/4DC1103F |
| Q1, Q2 | 2N3904 Transistor | 276-2016 | 625-2N3904 |

OPERATING THE LASER POINTER

Before operating the ML268 laser pointer for the first time, charge the batteries completely. Once the batteries are charged, the ML268 can be operated with or without the AC adapter/battery charger.

When operating the laser pointer, never point the laser beam toward anyone's eyes. This warning includes animals. See "Rules for Laser Safety" on the back cover.

1. Aim the aperture of the laser pointer toward the intended target.
2. To activate the laser beam, choose one of the following:
 - To keep the laser beam continuously on during use, position the ON/OFF switch to the ON position.
 - To turn the laser beam on intermittently, position the ON/OFF switch to the PUSH ON position. Press the red push-button switch to activate the laser beam and release the push-button to turn the laser off.
3. When finished using the ML268 laser pointer, position the ON/OFF switch to the OFF position. If the AC adapter/battery charger is plugged into an outlet, unplug it unless the batteries need to be charged.

NOTE: When the three-position slide switch on the back of the ML268 laser pointer is put into the "ON" position, a red band on the slider is displayed to give a visual indication of emission. And, when the three-position slide switch is in the "PUSH ON" position, emission is indicated by the clear, tactile feedback supplied by the "PUSH ON" normally off, momentary on push-button switch on the front of the unit. The laser will not turn on when trying to operate the ML268 with the AC adapter/battery charger plugged into the DC input jack but not plugged into an AC outlet.

SPECIFICATIONS

Table 2. Laser specifications.

| Parameter | Value |
|----------------------|---|
| Operating | |
| Input signal | Must not be great than 3 V peak-to-peak |
| Optical | |
| Polarization | Linear |
| Wavelength | 650.0 nm |
| Output power | 0.9 mW |
| Beam diameter | 3.0 mm |
| Beam divergence | 1.1 milliradians |
| Power | |
| Batteries | 3 rechargeable nickel-cadmium |
| Battery life | Up to 4 hours of continuous use |
| AC adapter/recharger | 115 V |
| Storage | |
| Dimensions | 140 x 32 x 32 mm |
| Weight | 1.93 kilograms |
| Temperature | -20° to 50° C |

BENEFITS OF THE ML268

- Laser pointer for lectures and audio visual shows
- Transmits voice, music or data over the laser beam
- Transmits video pictures (B&W or color)
- Sets up easily anywhere with internal batteries (included)
- Batteries can be recharged many times without opening laser case
- Reliable performance and exceptionally long laser life (10,000+ hours)

SERVICE AND MAINTENANCE

Periodic operation, maintenance and service of this laser are not required. The warranty will be voided if entry has been made to the laser housing and/or any screws removed.

In the unlikely event this laser malfunctions and you wish to have it repaired, please do the following:

- In writing, describe the problem, person to contact, phone number, and return address.
- Carefully pack the laser, power adapter, manual and written description in a strong box with sufficient packing material to prevent damage in shipment.
- Ship the package to:

INDUSTRIAL FIBER OPTICS
1725 WEST 1ST STREET
TEMPE, AZ 85281-7622

WARRANTY

Industrial Fiber Optics ML268 Modulated VLD Laser Pointers are warranted against defects in materials and workmanship for 2 years. The warranty will be voided if the laser components have been damaged or mishandled by the buyer, including entry to the laser housing and/or removal of screws.

Industrial Fiber Optics' warranty liability is limited to repair or replacement of any defective unit at the company's facilities, and does not include attendant or consequential damages. Repair or replacement may be made only after failure analysis at the factory. Authorized warranty repairs are made at no charge, and are guaranteed for the balance of the original warranty.

Industrial Fiber Optics will pay the return freight and insurance charges for warranty repair within the continental United States by United Parcel Service or Parcel Post. Any other delivery means must be paid for by the customer.

The costs of return shipments for lasers no longer under warranty must be paid by the customer. If an item is not under warranty, repairs will not be undertaken until the cost of such repairs has been approved, in writing, by the customer. Typical repair costs range from \$75 - \$250 and repairs usually take two to three weeks to complete.

When returning items for analysis and possible repair, please do the following:

- In a letter, describe the problem, person to contact, phone number and return address.
- Pack the laser, power adapter, manual and letter carefully in a strong box with adequate packing material, to prevent damage in shipment.
- Ship the package to:

INDUSTRIAL FIBER OPTICS

1725 WEST 1ST STREET
TEMPE, AZ 85281-7622

SHIPMENT DAMAGE CLAIMS

If damage to an Industrial Fiber Optics product should occur during shipping, it is imperative that it be reported immediately, both to the carrier and the distributor or salesperson from whom the item was purchased. **DO NOT CONTACT INDUSTRIAL FIBER OPTICS.**

Time is of the essence because damage claims submitted more than five days after delivery may not be honored. If shipping damage has occurred during shipment, please do the following:

- Make a note of the carrier company, the name of the carrier employee, the date and the time of the delivery.
- Keep all packing material.
- In writing, describe the nature of damage to the product.
- In cases of severe damage, do not attempt to use the product (including attaching it to a power source).
- Notify the carrier immediately of any damaged product.
- Notify the distributor from whom the purchase was made.

Rules for Laser Safety

- Lasers produce a very intense beam of light. Treat them with respect. Most educational lasers have an output of less than 3 milliwatts, and will not harm the skin.
- Never look into the laser aperture while the laser is turned on! PERMANENT EYE DAMAGE COULD RESULT.
- Never stare into the oncoming beam. Never use magnifiers (such as binoculars or telescopes) to look at the beam as it travels – or when it strikes a surface.
- Never point a laser at anyone's eyes or face, no matter how far away they are.
- When using a laser in the classroom or laboratory, always use a beam stop, or project the beam to areas, which people won't enter or pass through.
- Never leave a laser unattended while it is turned on – and always unplug it when it's not actually being used.
- Remove all shiny objects from the area in which you will be working. This includes rings, watches, metal bands, tools, and glass. Reflections from the beam can be nearly as intense as the beam itself.
- Never disassemble or try to adjust the laser's internal components. Electric shock could result.