

1-Mbit (64K x 16) Static RAM

Features

- **Temperature Ranges**
 - Commercial: 0°C to 70°C
 - Industrial: -40°C to 85°C
 - Automotive: -40°C to 125°C
- **High speed**
 - $t_{AA} = 12$ ns (Commercial & Industrial)
 - $t_{AA} = 15$ ns (Automotive)
- **CMOS for optimum speed/power**
- **Low active power**
 - 770 mW (max.)
- **Automatic power-down when deselected**
- **Independent control of upper and lower bits**
- **Available in Pb-free and non Pb-free 44-pin TSOP II and 44-pin 400-mil-wide SOJ**

Functional Description^[1]

The CY7C1021B is a high-performance CMOS static RAM organized as 65,536 words by 16 bits. This device has an

automatic power-down feature that significantly reduces power consumption when deselected.

Writing to the device is accomplished by taking Chip Enable (\overline{CE}) and Write Enable (\overline{WE}) inputs LOW. If Byte Low Enable (\overline{BLE}) is LOW, then data from I/O pins (I/O_1 through I/O_8), is written into the location specified on the address pins (A_0 through A_{15}). If Byte High Enable (\overline{BHE}) is LOW, then data from I/O pins (I/O_9 through I/O_{16}) is written into the location specified on the address pins (A_0 through A_{15}).

Reading from the device is accomplished by taking Chip Enable (\overline{CE}) and Output Enable (\overline{OE}) LOW while forcing the Write Enable (\overline{WE}) HIGH. If Byte Low Enable (\overline{BLE}) is LOW, then data from the memory location specified by the address pins will appear on I/O_1 to I/O_8 . If Byte High Enable (\overline{BHE}) is LOW, then data from memory will appear on I/O_9 to I/O_{16} . See the truth table at the back of this data sheet for a complete description of read and write modes.

The input/output pins (I/O_1 through I/O_{16}) are placed in a high-impedance state when the device is deselected (\overline{CE} HIGH), the outputs are disabled (\overline{OE} HIGH), the \overline{BHE} and \overline{BLE} are disabled (\overline{BHE} , \overline{BLE} HIGH), or during a write operation (\overline{CE} LOW, and \overline{WE} LOW).

The CY7C1021B is available in standard 44-pin TSOP Type II and 44-pin 400-mil-wide SOJ packages.

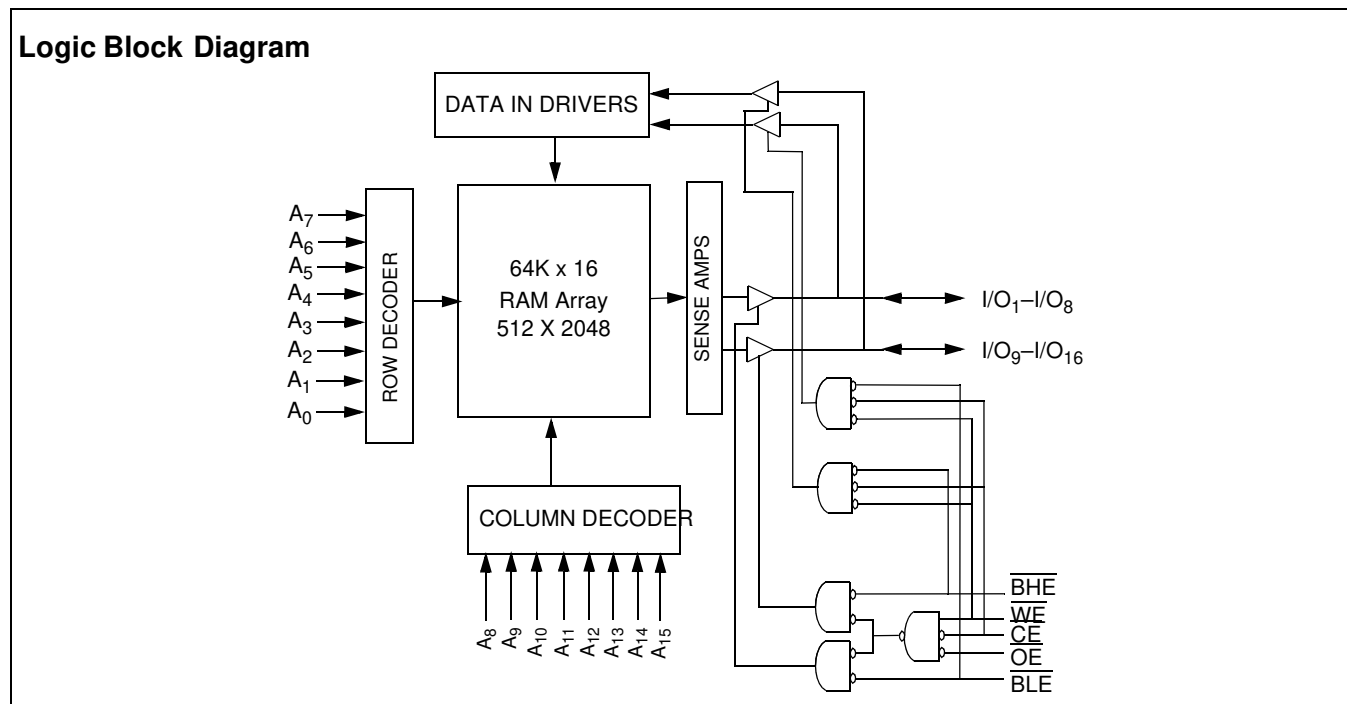

Note:

1. For best-practice recommendations, please refer to the Cypress application note "System Design Guidelines" on <http://www.cypress.com>.

Selection Guide

		-12	-15
Maximum Access Time (ns)		12	15
Maximum Operating Current (mA)	Com'l/Ind'l	140	130
	Automotive		130
Maximum CMOS Standby Current (mA)	Com'l/Ind'l	10	10
	Automotive		15
	L Version	0.5	0.5

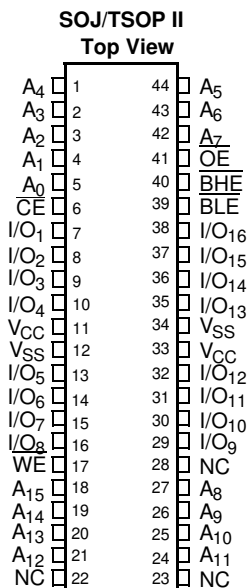
Pin Configurations

Pin Definitions

Pin Name	SOJ, TSOP–Pin Number	I/O Type	Description
A ₀ –A ₁₅	1–5, 18–21, 24–27, 42–44	Input	Address Inputs used to select one of the address locations.
I/O ₁ –I/O ₁₆	7–10, 13–16, 29–32, 35–38	Input/Output	Bidirectional Data I/O lines. Used as input or output lines depending on operation.
NC	22, 23, 28	No Connect	No Connects. Not connected to the die.
$\overline{\text{WE}}$	17	Input/Control	Write Enable Input, active LOW. When selected LOW, a Write is conducted. When deselected HIGH, a Read is conducted.
$\overline{\text{CE}}$	6	Input/Control	Chip Enable Input, active LOW. When LOW, selects the chip. When HIGH, deselects the chip.
$\overline{\text{BHE}}$, $\overline{\text{BLE}}$	40, 39	Input/Control	Byte Write Select Inputs, active LOW. $\overline{\text{BHE}}$ controls I/O ₁₆ –I/O ₉ , $\overline{\text{BLE}}$ controls I/O ₈ –I/O ₁ .
$\overline{\text{OE}}$	41	Input/Control	Output Enable, active LOW. Controls the direction of the I/O pins. When LOW, the I/O pins are allowed to behave as outputs. When deasserted HIGH, I/O pins are tri-stated, and act as input data pins.
V _{SS}	12, 34	Ground	Ground for the device. Should be connected to ground of the system.
V _{CC}	11, 33	Power Supply	Power Supply inputs to the device.

Maximum Ratings

(Above which the useful life may be impaired. For user guidelines, not tested.)

Storage Temperature -65°C to +150°C
 Ambient Temperature with Power Applied -55°C to +125°C
 Supply Voltage on V_{CC} Relative to GND^[2] -0.5V to +7.0V
 DC Voltage Applied to Outputs in High Z State^[2] -0.5V to V_{CC}+0.5V
 DC Input Voltage^[2] -0.5V to V_{CC}+0.5V
 Current into Outputs (LOW) 20 mA

Static Discharge Voltage >2001V (per MIL-STD-883, Method 3015)

Latch-Up Current >200 mA

Operating Range

Range	Ambient Temperature (T _A) ^[3]	V _{CC}
Commercial	0°C to +70°C	5V ± 10%
Industrial	-40°C to +85°C	5V ± 10%
Automotive	-40°C to +125°C	5V ± 10%

Electrical Characteristics Over the Operating Range

Parameter	Description	Test Conditions	-12		-15		Unit	
			Min.	Max.	Min.	Max.		
V _{OH}	Output HIGH Voltage	V _{CC} = Min., I _{OH} = -4.0 mA	2.4		2.4		V	
V _{OL}	Output LOW Voltage	V _{CC} = Min., I _{OL} = 8.0 mA		0.4		0.4	V	
V _{IH}	Input HIGH Voltage		2.2	6.0	2.2	6.0	V	
V _{IL}	Input LOW Voltage ^[2]		-0.5	0.8	-0.5	0.8	V	
I _{IX}	Input Leakage Current	GND ≤ V _I ≤ V _{CC}	Com'l/Ind'l	-1	+1	-1	+1	μA
			Auto			-4	+4	μA
I _{OZ}	Output Leakage Current	GND ≤ V _I ≤ V _{CC} , Output Disabled	Com'l/Ind'l	-1	+1	-1	+1	μA
			Auto			-4	+4	μA
I _{CC}	V _{CC} Operating Supply Current	V _{CC} = Max., I _{OUT} = 0 mA, f = f _{MAX} = 1/t _{RC}	Com'l/Ind'l		140		130	mA
			Auto				130	mA
I _{SB1}	Automatic CE Power Down Current —TTL Inputs	Max. V _{CC} , $\overline{CE} \geq V_{IH}$, V _{IN} ≥ V _{IH} or V _{IN} ≤ V _{IL} , f = f _{MAX}	Com'l/Ind'l		40		40	mA
			Auto				50	mA
I _{SB2}	Automatic CE Power Down Current —CMOS Inputs	Max. V _{CC} , $\overline{CE} \geq V_{CC} - 0.3V$, V _{IN} ≥ V _{CC} - 0.3V, or V _{IN} ≤ 0.3V, f = 0	Com'l/Ind'l		10		10	mA
			Auto				15	mA
			L Version		0.5		0.5	mA

Capacitance^[4]

Parameter	Description	Test Conditions	Max.	Unit
C _{IN}	Input Capacitance	T _A = 25°C, f = 1 MHz,	8	pF
C _{OUT}	Output Capacitance	V _{CC} = 5.0V	8	pF

Thermal Resistance^[4]

Parameter	Description	Test Conditions	44-pin SOJ	44-pin TSOP-II	Unit
Θ _{JA}	Thermal Resistance (Junction to Ambient)	Test conditions follow standard test methods and procedures for measuring thermal impedance, per EIA/JESD51.	64.32	76.89	°C/W
Θ _{JC}	Thermal Resistance (Junction to Case)		31.03	14.28	°C/W

Notes:

- V_{IL} (min.) = -2.0V and V_{IH} (max.) = V_{CC} + 0.5V for pulse durations of less than 20 ns.
- T_A is the "Instant On" case temperature.
- Tested initially and after any design or process changes that may affect these parameters.

AC Test Loads and Waveforms

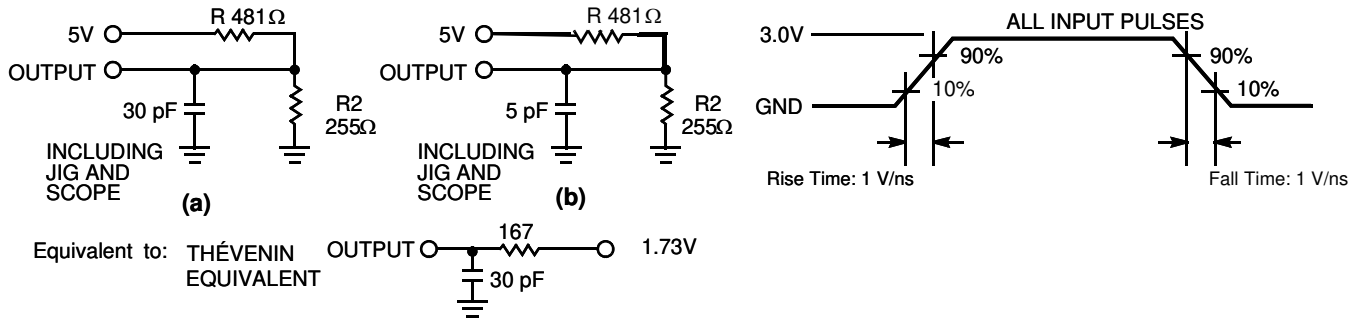

Switching Characteristics Over the Operating Range^[5]

Parameter	Description	7C1021B-12		7C1021B-15		Unit
		Min.	Max.	Min.	Max.	
Read Cycle						
t_{RC}	Read Cycle Time	12		15		ns
t_{AA}	Address to Data Valid		12		15	ns
t_{OHA}	Data Hold from Address Change	3		3		ns
t_{ACE}	\overline{CE} LOW to Data Valid		12		15	ns
t_{DOE}	\overline{OE} LOW to Data Valid		6		7	ns
t_{LZOE}	\overline{OE} LOW to Low Z ^[6]	0		0		ns
t_{HZOE}	\overline{OE} HIGH to High Z ^[6, 7]		6		7	ns
t_{LZCE}	\overline{CE} LOW to Low Z ^[6]	3		3		ns
t_{HZCE}	\overline{CE} HIGH to High Z ^[6, 7]		6		7	ns
t_{PU}	\overline{CE} LOW to Power-Up	0		0		ns
t_{PD}	\overline{CE} HIGH to Power-Down		12		15	ns
t_{DBE}	Byte Enable to Data Valid		6		7	ns
t_{LZBE}	Byte Enable to Low Z	0		0		ns
t_{HZBE}	Byte Disable to High Z		6		7	ns
Write Cycle^[8]						
t_{WC}	Write Cycle Time	12		15		ns
t_{SCE}	\overline{CE} LOW to Write End	9		10		ns
t_{AW}	Address Set-Up to Write End	8		10		ns
t_{HA}	Address Hold from Write End	0		0		ns
t_{SA}	Address Set-Up to Write Start	0		0		ns
t_{SD}	Data Set-Up to Write End	6		8		ns
t_{HD}	Data Hold from Write End	0		0		ns
t_{LZWE}	\overline{WE} HIGH to Low Z ^[6]	3		3		ns
t_{HZWE}	\overline{WE} LOW to High Z ^[6, 7]		6		7	ns
t_{BW}	Byte Enable to End of Write	8		9		ns

Notes:

- Test conditions assume signal transition time of 3 ns or less, timing reference levels of 1.5V, input pulse levels of 0 to 3.0V, and output loading of the specified I_{OL}/I_{OH} and 30-pF load capacitance.
- At any given temperature and voltage condition, t_{HZCE} is less than t_{LZCE} , t_{HZOE} is less than t_{LZOE} , and t_{HZWE} is less than t_{LZWE} for any given device.
- t_{HZOE} , t_{HZBE} , t_{HZCE} , and t_{HZWE} are specified with a load capacitance of 5 pF as in part (b) of AC Test Loads. Transition is measured ± 500 mV from steady-state voltage.
- The internal write time of the memory is defined by the overlap of \overline{CE} LOW, \overline{WE} LOW and $\overline{BHE}/\overline{BLE}$ LOW. \overline{CE} , \overline{WE} and $\overline{BHE}/\overline{BLE}$ must be LOW to initiate a write, and the transition of these signals can terminate the write. The input data set-up and hold timing should be referenced to the leading edge of the signal that terminates the write.

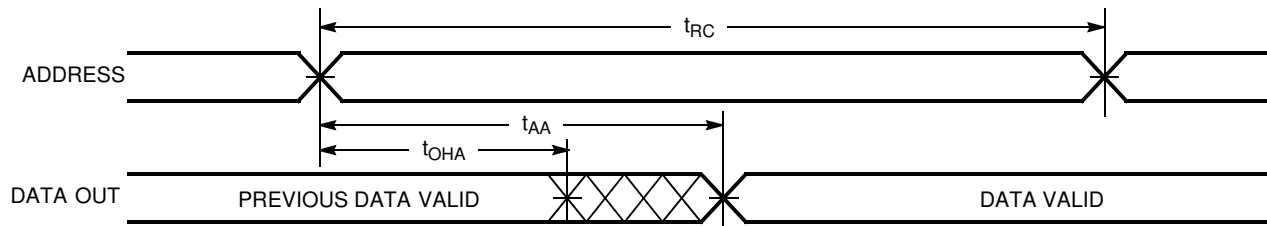
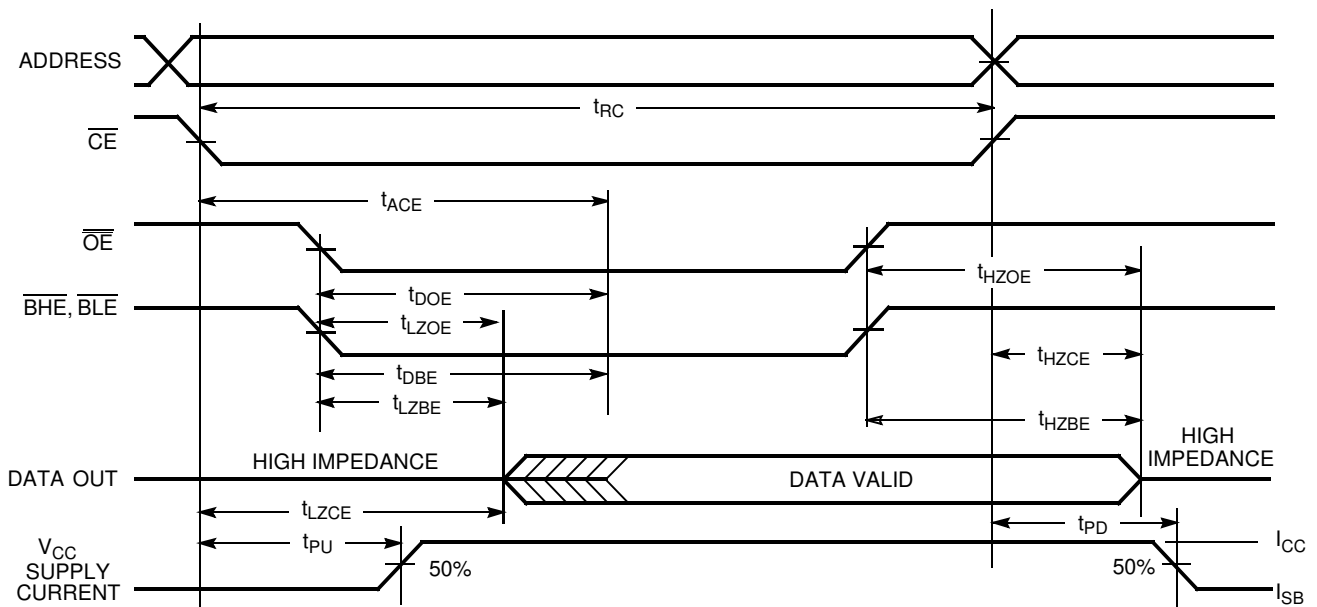
Switching Waveforms
Read Cycle No. 1^[9, 10]

Read Cycle No. 2 (\overline{OE} Controlled)^[10, 11]

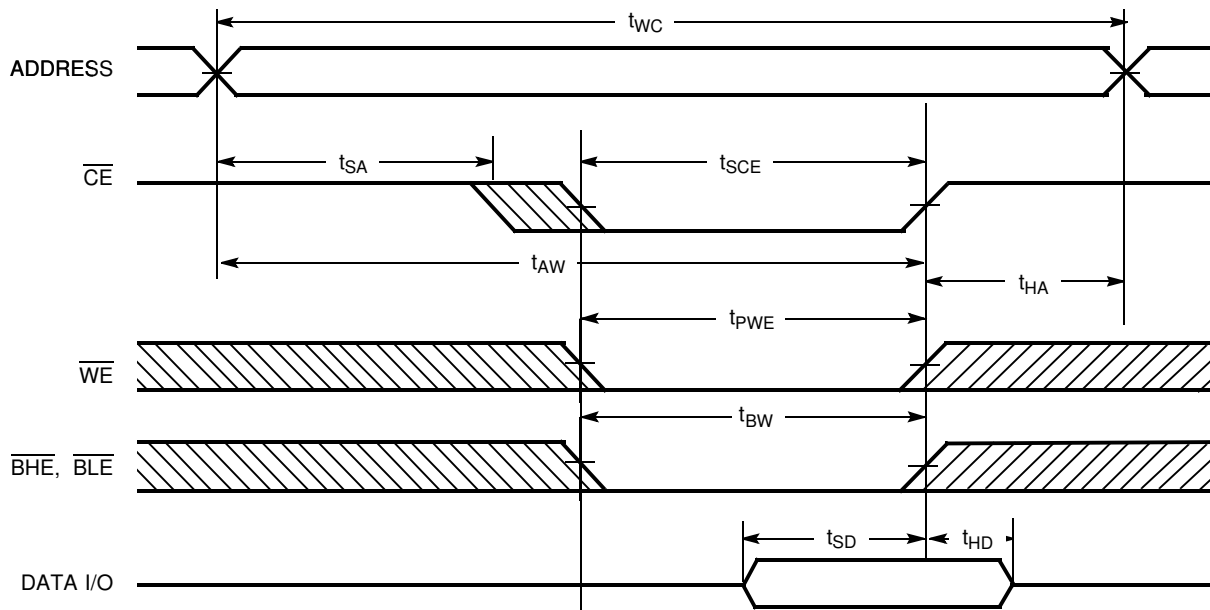
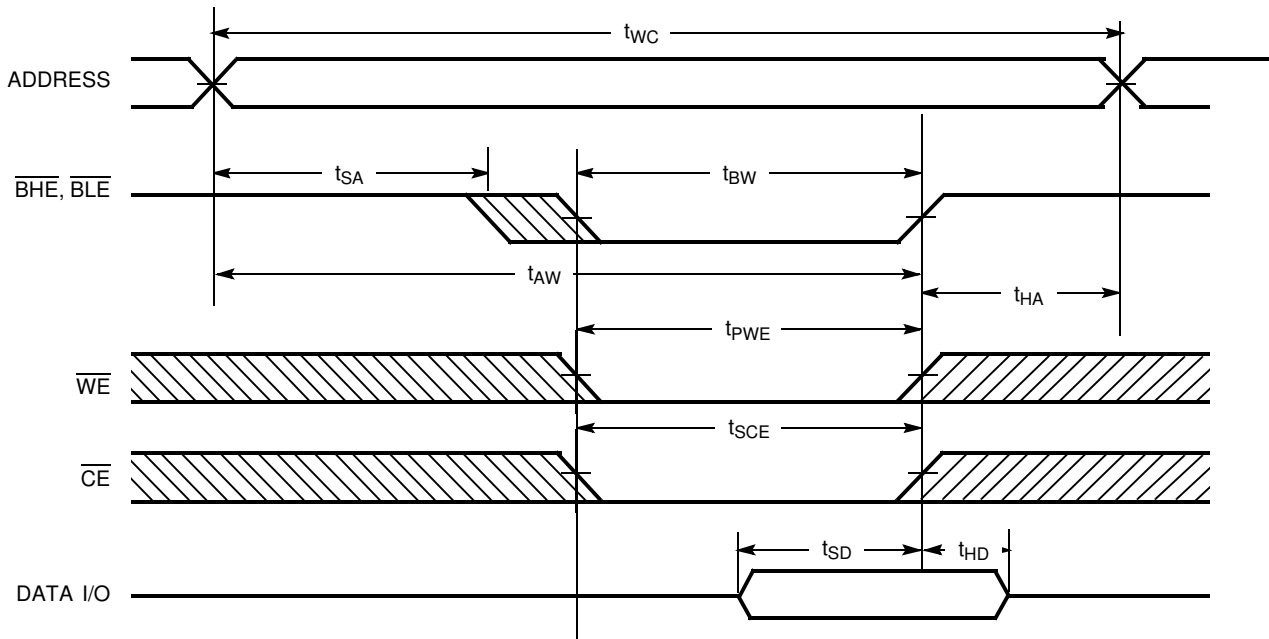
Notes:

- 9. Device is continuously selected. \overline{OE} , \overline{CE} , \overline{BHE} and/or \overline{BLA} = V_{IL} .
- 10. \overline{WE} is HIGH for read cycle.
- 11. Address valid prior to or coincident with \overline{CE} transition LOW.

Switching Waveforms (continued)
Write Cycle No. 1 ($\overline{\text{CE}}$ Controlled)^[12, 13]

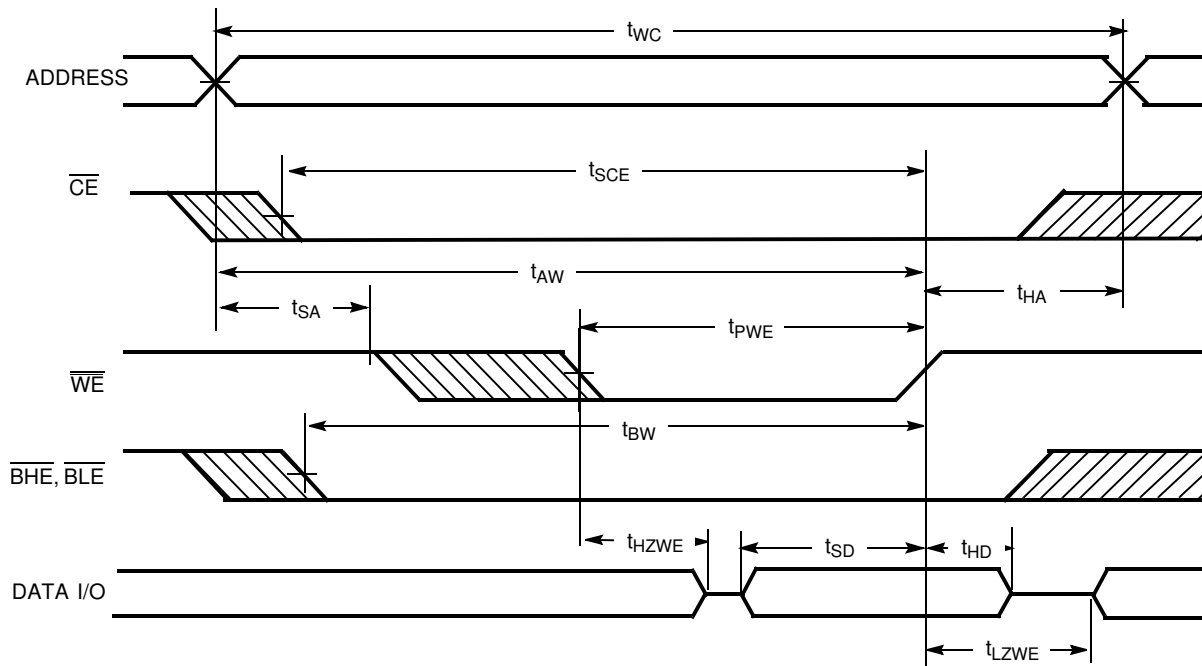
Write Cycle No. 2 ($\overline{\text{BLE}}$ or $\overline{\text{BHE}}$ Controlled)

Notes:

12. Data I/O is high impedance if $\overline{\text{OE}}$ or $\overline{\text{BHE}}$ and/or $\overline{\text{BLE}} = V_{IH}$.
13. If $\overline{\text{CE}}$ goes HIGH simultaneously with $\overline{\text{WE}}$ going HIGH, the output remains in a high-impedance state.

Switching Waveforms (continued)

Write Cycle No. 3 (\overline{WE} Controlled, \overline{OE} LOW)

Truth Table

\overline{CE}	\overline{OE}	\overline{WE}	\overline{BLE}	\overline{BHE}	I/O ₁ -I/O ₈	I/O ₉ -I/O ₁₆	Mode	Power
H	X	X	X	X	High Z	High Z	Power-Down	Standby (I_{SB})
L	L	H	L	L	Data Out	Data Out	Read - All bits	Active (I_{CC})
			L	H	Data Out	High Z	Read - Lower bits only	Active (I_{CC})
			H	L	High Z	Data Out	Read - Upper bits only	Active (I_{CC})
L	X	L	L	L	Data In	Data In	Write - All bits	Active (I_{CC})
			L	H	Data In	High Z	Write - Lower bits only	Active (I_{CC})
			H	L	High Z	Data In	Write - Upper bits only	Active (I_{CC})
L	H	H	X	X	High Z	High Z	Selected, Outputs Disabled	Active (I_{CC})
L	X	X	H	H	High Z	High Z	Selected, Outputs Disabled	Active (I_{CC})

Ordering Information

Speed (ns)	Ordering Code	Package Name	Package Type	Operating Range
12	CY7C1021B-12VC	51-85082	44-pin (400-Mil) Molded SOJ	Commercial
	CY7C1021B-12VXC		44-pin (400-Mil) Molded SOJ (Pb-Free)	
	CY7C1021B-12ZC	51-85087	44-pin TSOP Type II	
	CY7C1021B-12ZXC		44-pin TSOP Type II (Pb-Free)	
	CY7C1021B-12VI	51-85082	44-pin (400-Mil) Molded SOJ	Industrial
	CY7C1021B-12VXI		44-pin (400-Mil) Molded SOJ (Pb-Free)	

Ordering Information (continued)

Speed (ns)	Ordering Code	Package Name	Package Type	Operating Range
15	CY7C1021B-15VC	51-85082	44-pin (400-Mil) Molded SOJ	Commercial
	CY7C1021B-15VXC		44-pin (400-Mil) Molded SOJ (Pb-Free)	
	CY7C1021B-15ZC	51-85087	44-pin TSOP Type II	
	CY7C1021B-15ZXC		44-pin TSOP Type II (Pb-Free)	
	CY7C1021B-15VI	51-85082	44-pin (400-Mil) Molded SOJ	Industrial
	CY7C1021B-15VXI		44-pin (400-Mil) Molded SOJ (Pb-Free)	
	CY7C1021B-15ZI	51-85087	44-pin TSOP Type II	
	CY7C1021BL-15ZI		44-pin TSOP Type II	
	CY7C1021B-15ZXI	51-85087	44-pin TSOP Type II (Pb-Free)	
	CY7C1021BL-15ZXI		44-pin TSOP Type II (Pb-Free)	
	CY7C1021B-15VE	51-85082	44-pin (400-Mil) Molded SOJ	Automotive
	CY7C1021B-15VXE		44-pin (400-Mil) Molded SOJ (Pb-Free)	
	CY7C1021B-15ZE	51-85087	44-pin TSOP Type II	
	CY7C1021B-15ZSXE		44-pin TSOP Type II (Pb-Free)	

Package Diagrams

44-pin (400-Mil) Molded SOJ (51-85082)

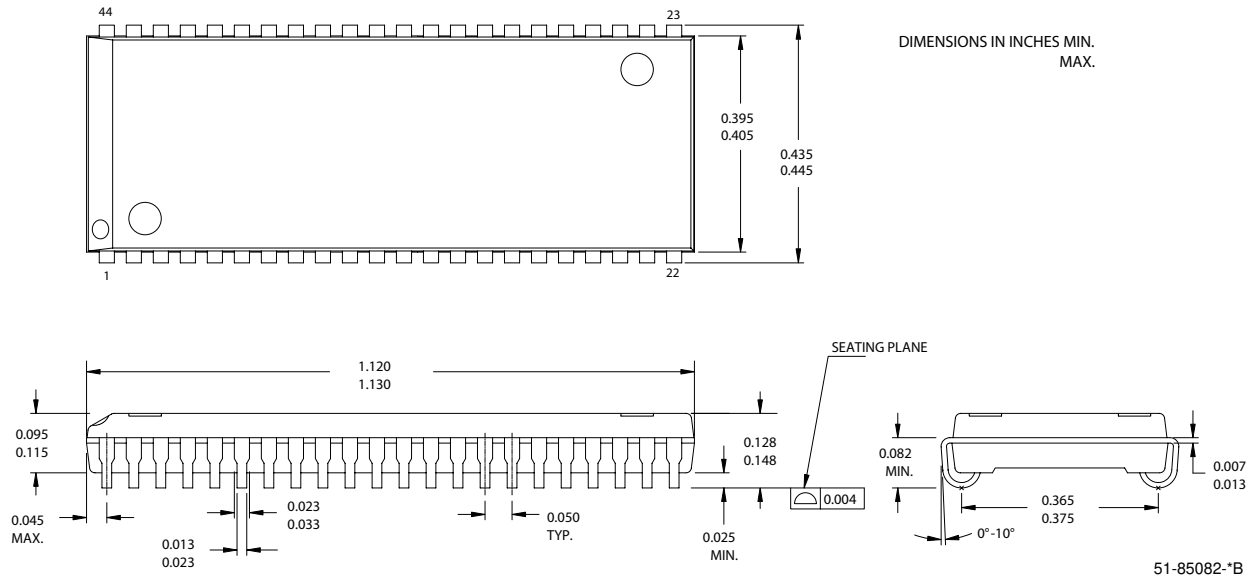

Package Diagrams (continued)

44-Pin TSOP II (51-85087)

DIMENSION IN MM (INCH)
MAX
MIN

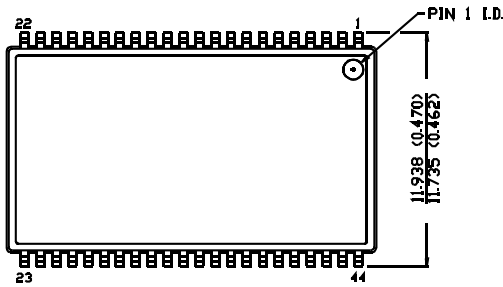

TOP VIEW

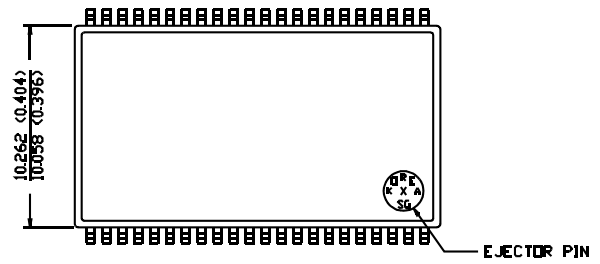

BOTTOM VIEW

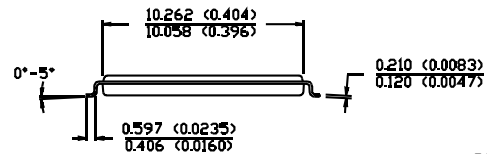
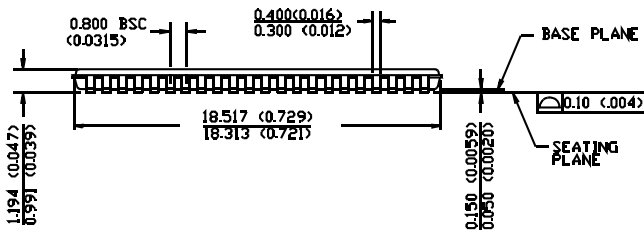

51-85087-A

All products and company names mentioned in this document may be the trademarks of their respective holders.

Document History Page

Document Title: CY7C1021B 1-Mbit (64K x 16) Static RAM				
Document Number: 38-05145				
REV.	ECN NO.	Issue Date	Orig. of Change	Description of Change
**	109889	09/22/01	SZV	Change from Spec number: 38-00951 to 38-05145
*A	238454	See ECN	RKF	1) Added Automotive Specs to Data Sheet 2) Added Pb-Free device offering in the Ordering Information
*B	361795	See ECN	SYT	Added Pb-Free offerings in the Ordering Information
*C	505726	See ECN	NXR	Removed CY7C10211B from Product offering Changed the description of I_{IX} from Input Load Current to Input Leakage Current in DC Electrical Characteristics table Changed teh I_{CC} Max value from 150 mA to 130 mA Removed I_{OS} parameter from DC Electrical Characteristics table Updated Ordering Information Table