

ALL DIMENSIONS ARE FOR REFERENCE ONLY.

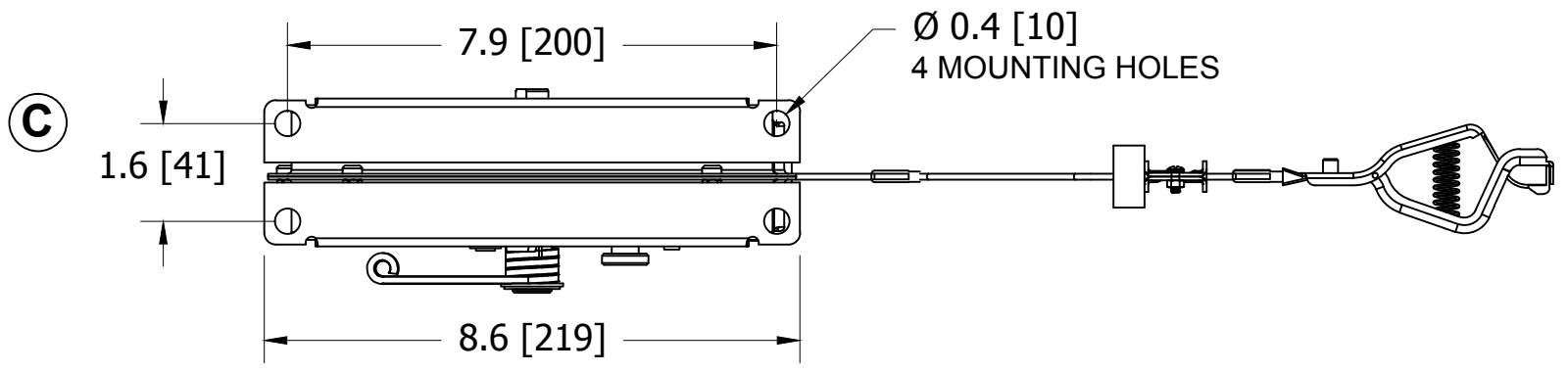
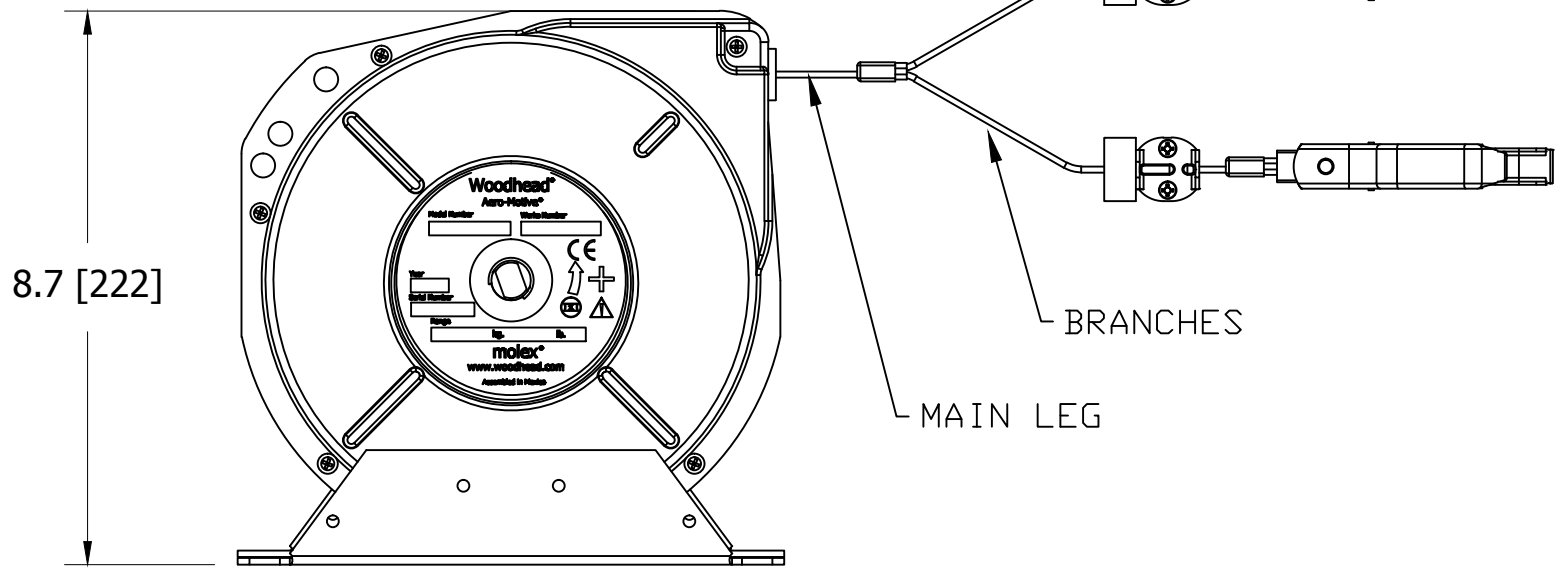
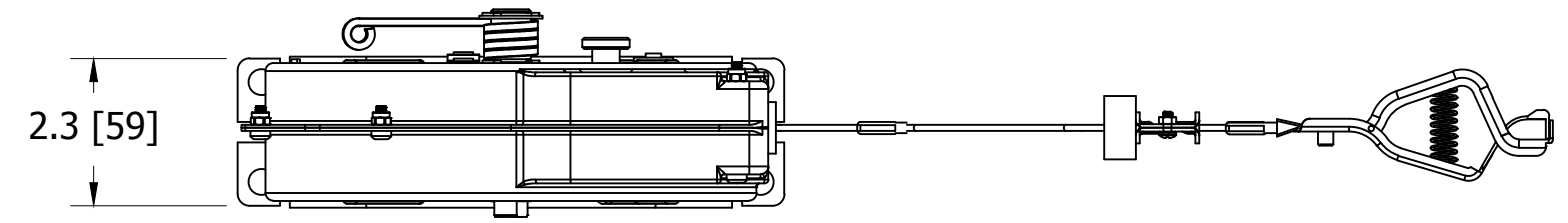
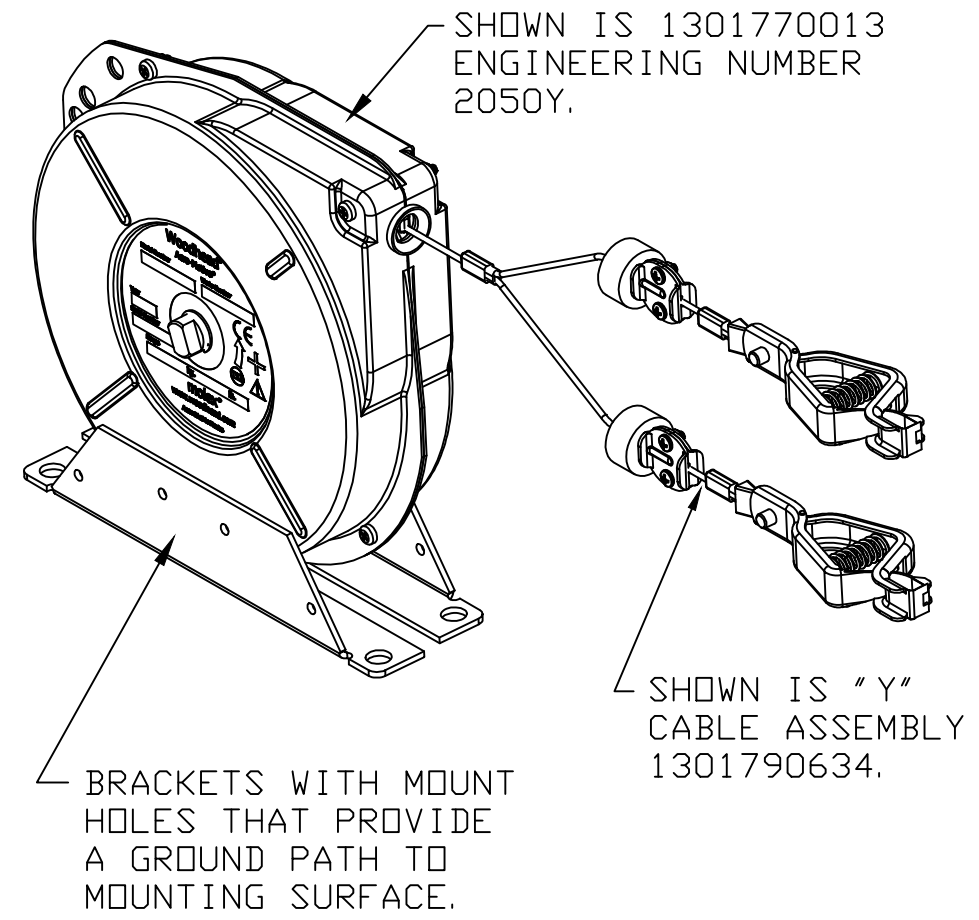

- NOTES:
1. STATIC REELS ARE 100% INSPECTED & PRE-TENSIONED AT FACTORY.
 2. HOUSINGS ARE MADE OF STEEL WITH POWDER COATING TO MEET HARSH INDUSTRIAL ENVIRONMENTS.
 3. ALWAYS READ INSTRUCTIONS MANUAL BEFORE USING STATIC REELS.
 4. STATIC REELS PROVIDE LIGHT, CONSTANT SPRING TENSION ON CABLE.
 5. STATIC REELS ARE EQUIPPED WITH 100A GROUND CLAMP.
 6. STATIC REELS HAVE MOUNTING BRACKETS WITH MOUNTING HOLES. WHEN MOUNTING THESE MAKE SURE THAT A GROUND PATH IS AVAILABLE FOR STATIC DISCHARGE.
 7. STATIC REELS HAVE THE OPTION OF HAVING A "Y" BRIDLE CABLE ASSEMBLY WITH 2 GROUNDING CLAMPS THAT ALLOW SIMULTANEOUS GROUNDING AT TWO POINTS.
 8. STATIC REELS WITH "Y" BRIDLE CABLE ASSEMBLY HAVE A 30FT[9.1M] PAYOUT FOR MAIN LEG & ANOTHER 20FT[6.1M] FOR EACH OF THE BRIDLE'S BRANCHES.

ADD MOUNTING HOLE DIM EC NO: IPG2018-0147 DRWN: VOU CHKD: BPATTERS 2017/10/02 APPR: JFMURPHY 2010/08/18	QUALITY SYMBOLS ▽=0 ◻=0	GENERAL TOLERANCES (UNLESS SPECIFIED)		DIMENSION STYLE IN [MM]		SCALE NTS	DESIGN UNITS INCH	THIRD ANGLE PROJECTION		
		4 PLACES	±-	±-	DRAWN BY	DATE	TITLE 2050 SERIES STATIC REELS SALES DRAWING			
		3 PLACES	±-	±.005	CHECKED BY	DATE				
		2 PLACES	±0.13	±.010	APPROVED BY	DATE	MATERIAL NO. SEE TABLE		DOCUMENT NO. SD-130177-001	
DRAFT WHERE APPLICABLE MUST REMAIN WITHIN DIMENSIONS		ANGULAR ±1°		SIZE B		THIS DRAWING CONTAINS INFORMATION THAT IS PROPRIETARY TO MOLEX INCORPORATED AND SHOULD NOT BE USED WITHOUT WRITTEN PERMISSION				

ITEM:	MATERIAL NUMBER:	ENGINEERING NUMBER:	DESCRIPTION:
1	1301794791	9709-545	DRUM & SPRING ASSY FOR 1025/2050 REELS
2	1301790623	9685-4-1	9685-4 STATIC REEL HSNG - POWDER BLUE
3	1301790625	H22520009-2-1	MAIN HOUSING ASSEMBLY-LOCK SIDE- BLUE
4	1301792177	9674-2-RP	SCROLL LOCK LEVER KIT
5	1301792444	9816-2-RP	CAM ZINC PLATED FOR 10FLR
6	1301792327	9733-RP	NYLON WASHER
7	1301790132	9808	SCROLL LOCK RELEASE KNOB
8	1301792355	14099-RP	WASHER -.63 I.D.x.88 O.D.x.02 W - BZP
9	1302344666	13613	GUIDE - CABLE OUTLET
10	1301792308	580-P-30-RP	EXTERNAL CIRCLIP 0.375" SHAFT
11	1301792357	9611-1-RP	MAIN SHAFT SPACER FOR 10F/15F/22F
12	1301792354	9616UK-RP	TENSION LOCK SPRING FOR 10F/15F/22F
13	1301792097	AG10310-RP	RET RING-ANDERTON N1500-62:BZP
14	1301792430	AG18769-RP	SHIM WASHER 16mmODx10mmIDx0.5mmTK
15	1301792353	9813-RP	SPACER WASHER .625 ID x 1.0 OD x .05 TK
16	SEE CHART	SEE CHART	SEE PART NUMBER TABLE FOR USAGE
17	1302344710	AG14612	SCREW M4X10LG Posi PHEAD BZP
18	1301792197	AG14614-RP	SCREW M4X45 LG Posi PHEAD BZP
19	1302344713	AG14615	M4 NYLOC NUT
20	1301790632	651-P-10	CLAMP GROUND FOR 1025 STATIC REELS
21	1301792100	580-P-35-RP	EXTERNAL CIRCLIP 0.625" SHAFT
22	1302344724	AG18723	M4 WHIZZ NUT SERRATED
23	N/A	M1306012Y	LABEL NOT FOR RESALE PURPOSES.

(C)

SHOWN IS 1301770009
ENGINEERING NUMBER
2050

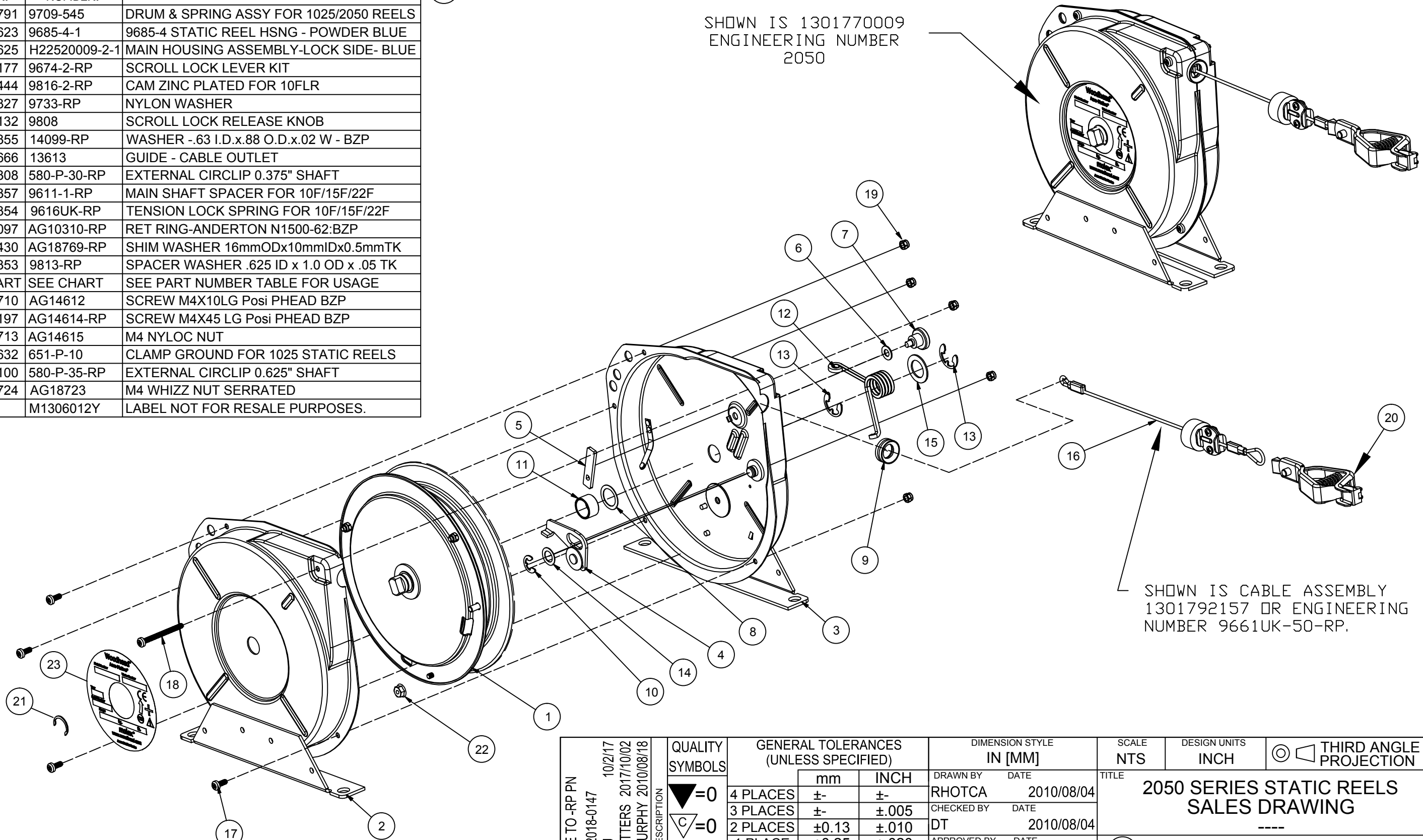

SHOWN IS CABLE ASSEMBLY
1301792157 OR ENGINEERING
NUMBER 9661UK-50-RP.

UPDATE TO -RP PN EC NO: IPG2018-0147 DRWN: VOU CHKD: BPATTERS 2017/10/02 APPR: JFMURPHY 2010/08/18	QUALITY SYMBOLS ▽=0 (C)=0	GENERAL TOLERANCES (UNLESS SPECIFIED)		DIMENSION STYLE		SCALE	DESIGN UNITS	THIRD ANGLE PROJECTION		
				IN [MM]		NTS	INCH			
		4 PLACES	±-	±-	DRAWN BY	DATE	TITLE 2050 SERIES STATIC REELS SALES DRAWING			
		3 PLACES	±-	±.005	RHOTCA	2010/08/04				
2 PLACES	±0.13	±.010	CHECKED BY	DATE	MOLEX INCORPORATED					
1 PLACE	±0.25	±.020	DT	2010/08/04						
ANGULAR ±1°		DRAFT WHERE APPLICABLE MUST REMAIN WITHIN DIMENSIONS		APPROVED BY	DATE	DOCUMENT NO.		SHEET NO.		
				DTITUS	2010/08/18	SD-130177-001		2 OF 3		
				MATERIAL NO. SEE TABLE		THIS DRAWING CONTAINS INFORMATION THAT IS PROPRIETARY TO MOLEX INCORPORATED AND SHOULD NOT BE USED WITHOUT WRITTEN PERMISSION				
				SIZE B						

10 9 8 7 6 5 4 3 2 1

C

Material Number:	Engineering Number:	Description:	Weight Range in (KG):	Cable Travel in (M):	Weight Range in (LB):	Cable Travel in (FT):	USES CABLE ASSY:		"R" OHMS:	Color:
							MATERIAL NUMBER	ENGINEERING NUMBER		
1301770015	1025	STATIC REEL [12LB/5.44KG] - 25FT[7.6M]	5.44	7.6	12	25	1301792161	9847-2-RP	2	BLUE
1301770009	2050	STATIC REEL [12LB/5.44KG] - 50FT[15.3M]	5.44	15.3	12	50	1301792157	9661UK-50-RP	2	BLUE
1301770011	2050NC	2050 REEL [12LB/5.44KG] W/NYLON CABLE	5.44	15.3	12	50	1301790690	9719UK-50	2	BLUE
1301770013	2050Y	STATIC REEL Y [12LB/5.44KG]-50FT[15.3M]	5.44	15.3	12	30 + 20	1301790634	41071UK-3	2	BLUE
1301770003	143025	STATIC REEL [12LB/5.44KG] - 25FT[7.6M]	5.44	7.6	12	25	1301792161	9847-2-RP	2	BLUE
1301770005	143050	STATIC REEL W/CABLE ASSY - 50FT[15.3M]	5.44	15.3	12	50	1301792157	9661UK-50-RP	2	BLUE
1301770006	143050NC	143050 W/NYLON CABLE ASSY - 50FT[15.3M]	5.44	15.3	12	50	1301790690	9719UK-50	2	BLUE
1301770008	143051	STATIC REEL Y[12LB/5.44KG] - 50FT[15.3M]	5.44	15.3	12	30 + 20	1301790634	41071UK-3	2	BLUE

F

E

D

C

B

A

F

E

D

C

B

A

UPDATE TO -RP PN EC NO: ICG2018-0147 DRWN: VOU CHKD: BPATTERS 2017/10/02 APPR: JFMURPHY 2010/08/18	DESCRIPTION REV	QUALITY SYMBOLS	GENERAL TOLERANCES (UNLESS SPECIFIED)		DIMENSION STYLE IN [MM]		SCALE NTS	DESIGN UNITS INCH	THIRD ANGLE PROJECTION			
		▽=0 ∇=0	4 PLACES	mm	INCH	DRAWN BY	DATE	2050 SERIES STATIC REELS SALES DRAWING ----				
			3 PLACES	±-	±-	RHOTCA	2010/08/04					
			2 PLACES	±0.13	±0.10	CHECKED BY	DATE					
			1 PLACE	±0.25	±0.20	DT	2010/08/04					
ANGULAR ±1°			APPROVED BY		DATE	MOLEX INCORPORATED MOLEX						
DRAFT WHERE APPLICABLE MUST REMAIN WITHIN DIMENSIONS			DTITUS		2010/08/18							
				MATERIAL NO.		DOCUMENT NO.			SHEET NO.			
				SEE TABLE		SD-130177-001			3 OF 3			
				SIZE B		THIS DRAWING CONTAINS INFORMATION THAT IS PROPRIETARY TO MOLEX INCORPORATED AND SHOULD NOT BE USED WITHOUT WRITTEN PERMISSION						

10 9 8 7 6 5 4 3 2 1