

**Instruction manual
for Evaluation Board
- MTO-EV019(TB67B000HG) -**

July 10, 2019

Rev.1.1

【Outline】

The TB67B000HG is a high-voltage PWM three-phase brushless DC (BLDC) motor driver.

The product integrates a sine-wave PWM/wide-angle commutation controller and the high-voltage driver in a single package (“two-in-one”).

So, it’s realizing the rating of 500 V and 2.0 A per one phase.

It is designed to change the speed of a BLDC directly motor by using a speed control signal (analog) from a microcontroller.

This evaluation board equipped with motor evaluation function can control a motor by connecting the motor to the external hall element.

Please sense excellent controllability of three-phase BLDC motor by applying the TB67B000HG.

【Note】

In using, please be careful about the thermal condition sufficiently.

As for each control signal, please refer to the IC specification by accessing to the below URL.

<http://toshiba.semicon-storage.com/us/product/linear/motordriver/detail.TB67B000HG.html>

Further, the application of this evaluation board is limited to the purpose of evaluating and learning the motor control. Please do not ship them to a market.

Note in Using a Motor

Use the motor whose phase relation of the hall element and the induced voltage is shown in the below timing charts.

When CW/CCW = H

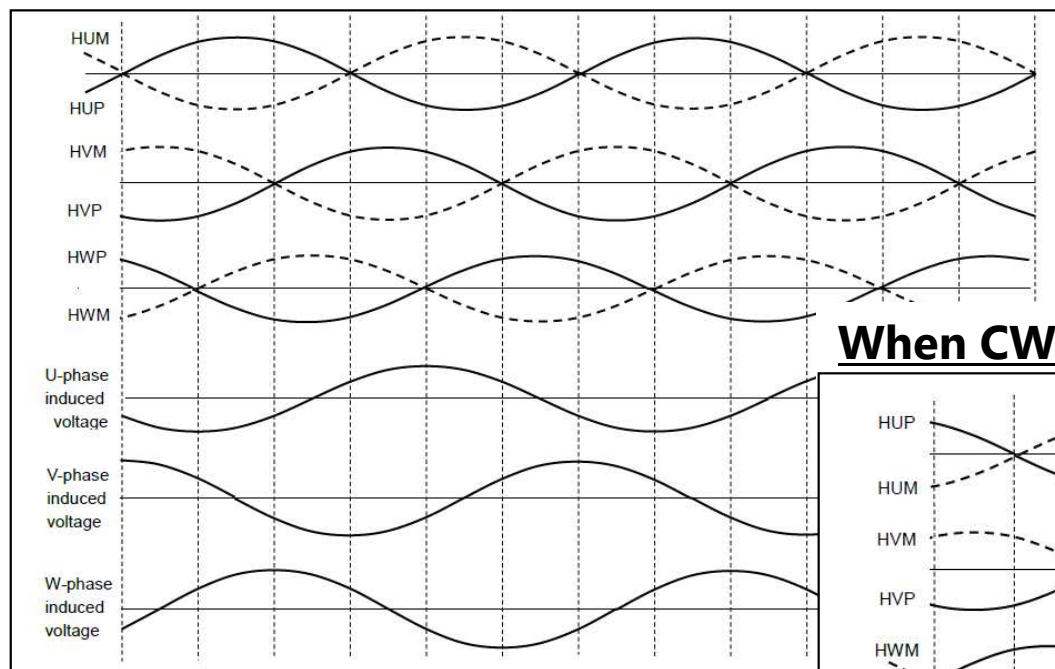

When CW/CCW = L

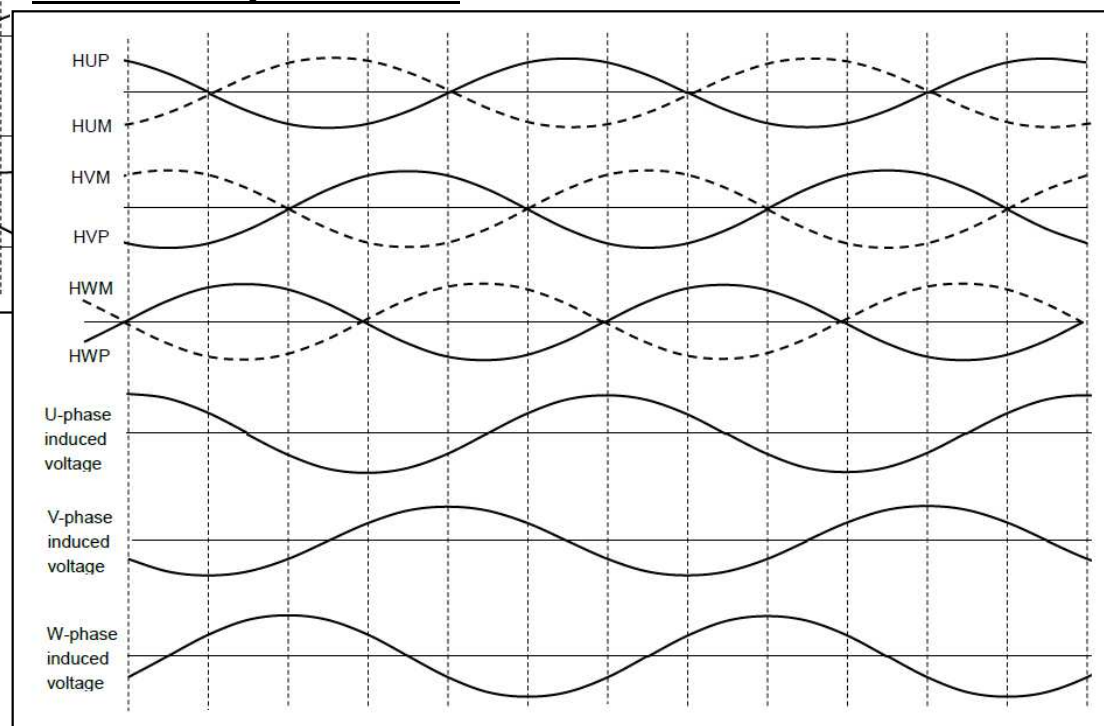

Connection of EV board and motor with Hall element

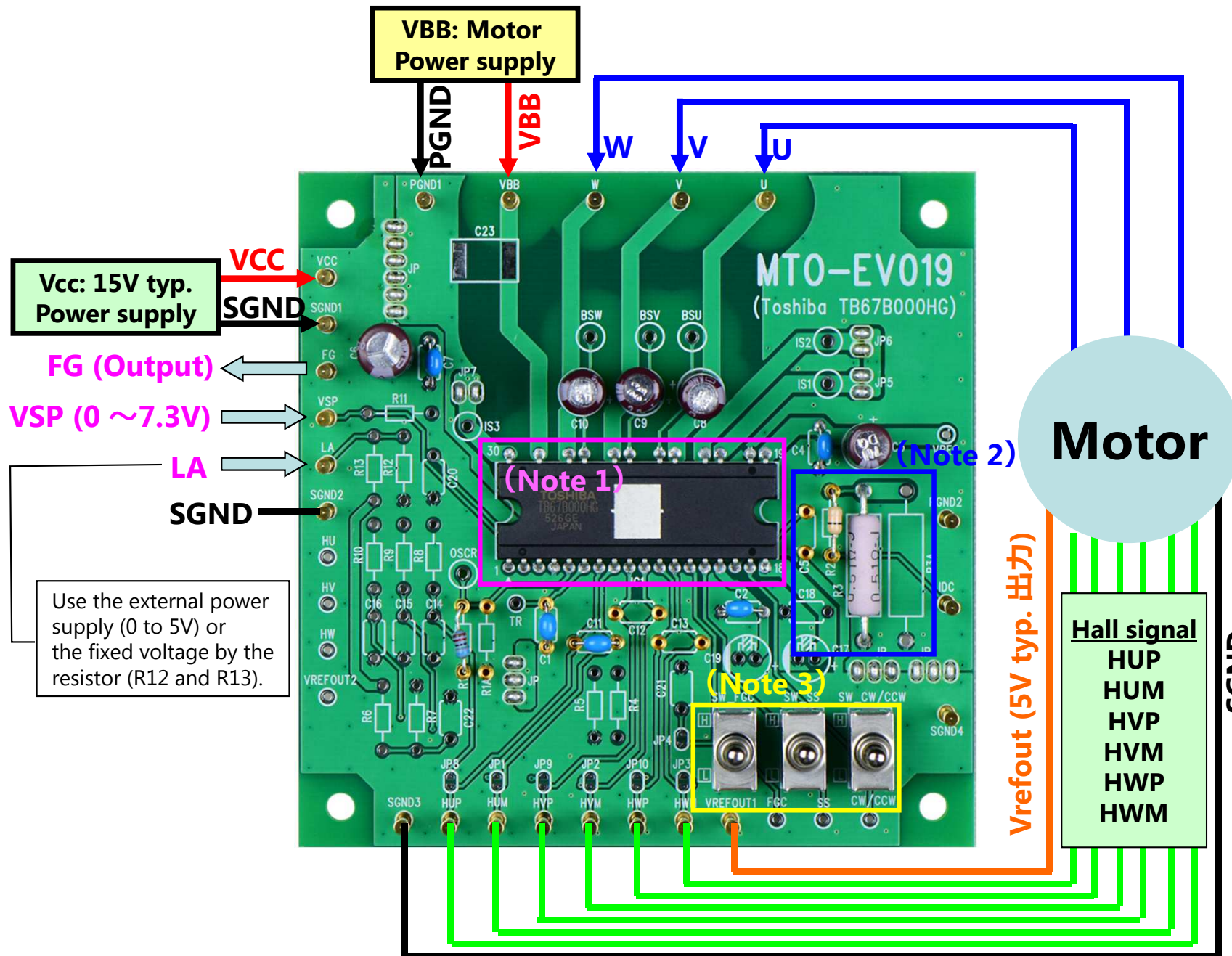

For example

Name	Value
R6	-
R7	-
R8	-
R9	-
R10	-
C11	0.1uF
C12	0.1uF
C13	0.1uF
C14	-
C15	-
C16	-
C22	-
JP1	-
JP2	-
JP3	-
JP8	-
JP9	-
JP10	-

Connection of EV board and motor with Hall IC

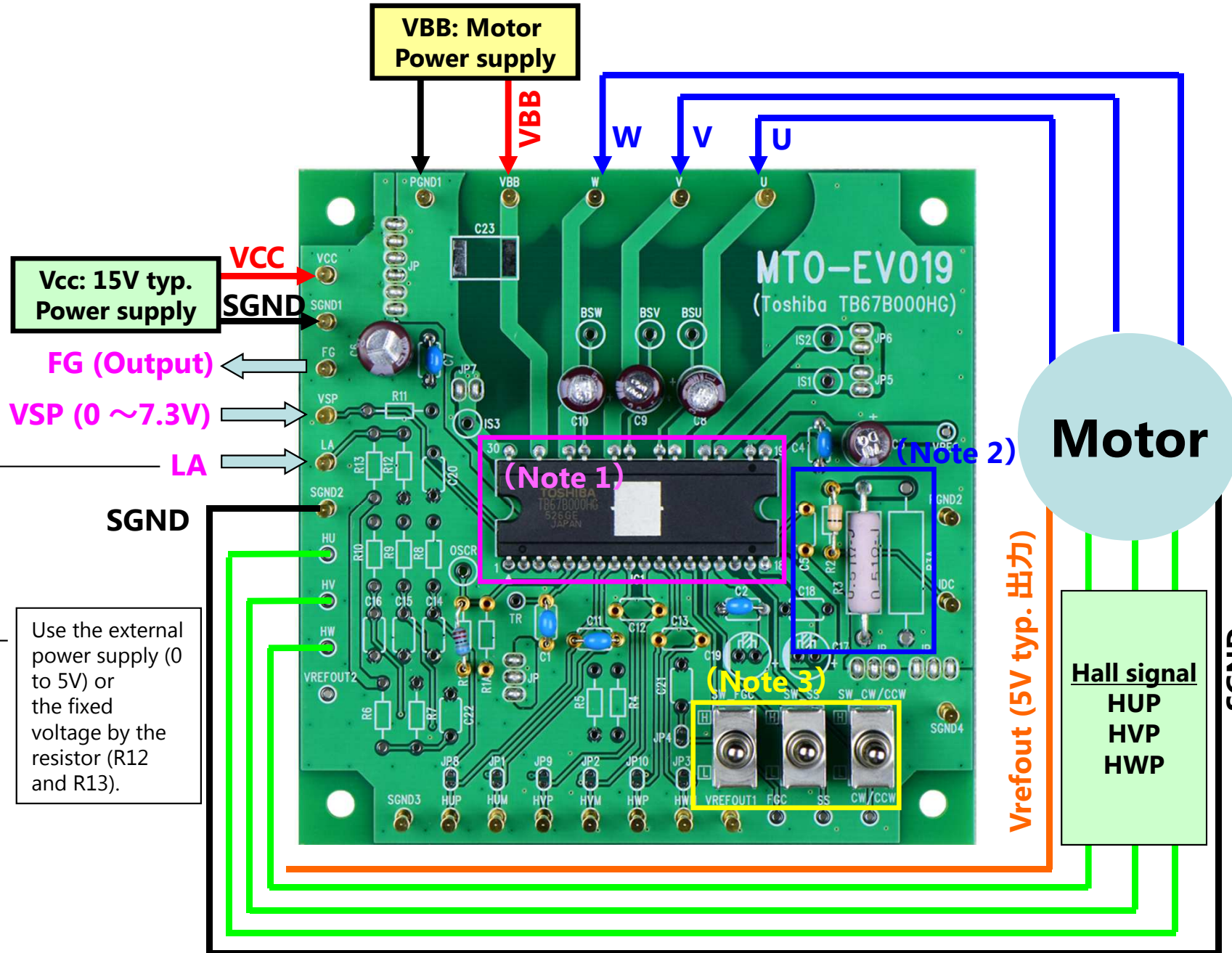

For example

Name	Value
R6	10kΩ
R7	10kΩ
R8	1kΩ
R9	1kΩ
R10	1kΩ
C11	-
C12	-
C13	-
C14	0.01uF
C15	0.01uF
C16	0.01uF
C22	-
JP1	Short
JP2	Short
JP3	Short
JP8	Short
JP9	Short
JP10	Short

Motor operation sequence and Notes

-Method of motor operation start

1. Apply VCC, VBB and Vsp

- Vcc = 15V(typ)
- VBB = 50 to 450V
- Vsp = 0V
- LA = 0 to 5V (In case of external power supply)

2. Apply Vsp from 0V and increase gradually the voltage of Vsp.

- Method of motor operation stop

1. Vsp = 0V
2. VBB = OFF,
LA = OFF
Vcc(15V) = OFF

Note1:

Use the heat sink on IC, if necessary.

Note2:

Use the shunt resistor(R3, R3A) and the filter for noise(R2, C5), if necessary.
(Over-current detection) $I_{out} (max) = V_{dc} / R3$ ($V_{dc} = 0.5 V$ (typ.))

Note3:

Switch for FGC, SS, CW/CCW pin
These pins must be fixed H or L level.

Pin name	H/L	Description
FGC	H	FG: output 1ppr
	L	FG: output 3ppr
SS	H	Wide-angle commutation
	L	Sine-wave PWM drive
CW/CCW	H	Forward
	L	Reverse

Circuit diagram

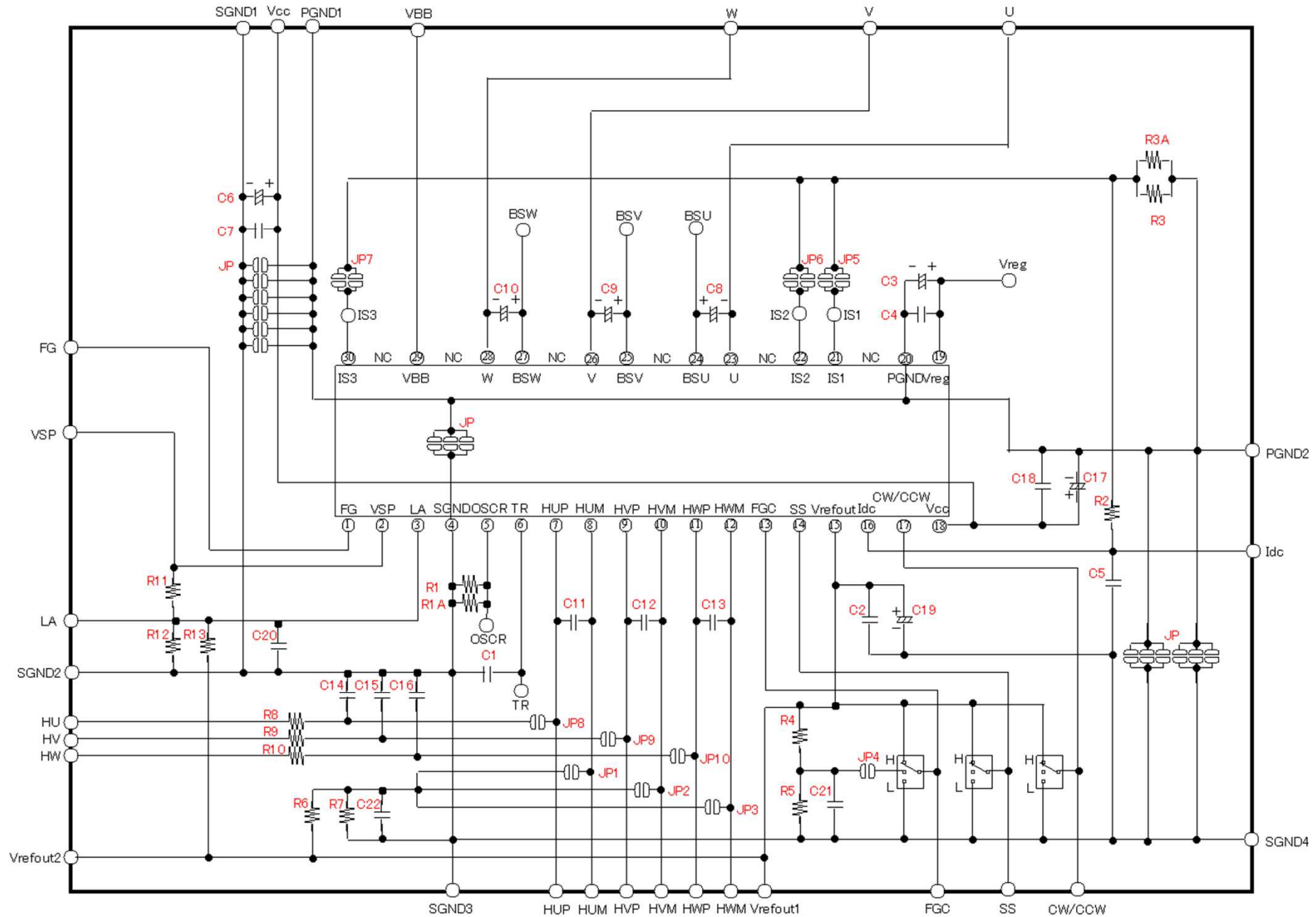

The value of external parts 1

	Name	Value	Note
Resistor	R1	68kΩ	-
	R1A	-	
	R2	short	Use the shunt resistor(R3, R3A) and the filter for noise(R2, C5), if necessary. (Over-current detection) $I_{out} (max) = V_{dc} / R3$ ($V_{dc} = 0.5 V$ (typ.))
	R3	short	
	R3A	-	
	R4	-	-
	R5	-	
	R6	-	Please use when the motor with hall IC.
	R7	-	
	R8	-	
	R9	-	
	R10	-	
	R11	-	-
R12	-	Use to apply the fixed voltege to LA, if necessary.	
R13	-		

The value of external parts 2

	Name	Value	Note
Capacitor	C1	0.01uF	If no need function of Motor lock detection, please short.
	C2	0.1uF	-
	C3	1uF	-
	C4	0.001uF	-
	C5	-	Use the shunt resistor(R3, R3A) and the filter for noise(R2, C5), if necessary. (Over-current detection)
	C6	10uF	-
	C7	0.1uF	-
	C8	2.2uF	-
	C9	2.2uF	-
	C10	2.2uF	-
	C11	0.1uF	-
	C12	0.1uF	-
	C13	0.1uF	-
	C14	-	Please use when the motor with hall IC.
	C15	-	
	C16	-	
	C17	-	-
	C18	-	-
	C19	-	-
	C20	-	Use to apply the fixed voltege to LA, if necessary.
	C21	-	-
	C22	-	Please use when the motor with hall IC.

The value of external parts 3

	Name	Value	Note
Jumper	JP1	-	Please use when the motor with hall IC.
	JP2	-	
	JP3	-	
	JP4	-	-
	JP5	short	-
	JP6	short	-
	JP7	short	-
	JP8	-	Please use when the motor with hall IC.
	JP9	-	
	JP10	-	
	JP	short	There are 15pcs.

◆ Important Note ◆

● This product was not designed for use with devices which could cause personal injury in the event of failure or malfunction, including devices for use in areas including medical, military, aviation, aerospace, nuclear control, other types of safety mechanisms, etc., or for use in devices which require a high standard of safety. Do not use this product for such applications. This company assumes no liability for damages which may result from use of the product.

Manufactured and Distributed by



<https://www.marutsu.com>

Marutsuelec Co., Ltd.

5-2-2, Seiki Daiichi Building 7F, Sotokanda, Chiyoda-ku,
Tokyo 101-0021, Japan

Tel: +81-3-6803-0209 FAX: +81-3-6803-0213