

OSRAM LZ4-00W408

Datasheet

Published by **ams-OSRAM AG**

Tobelbader Strasse 30, 8141 Premstaetten, Austria

Phone +43 3136 500-0

ams-osram.com

© All rights reserved



LED ENGIN LuxiGen

LZ4-00W408

Industry most robust high power ceramic package with glass lens for high performance over life.

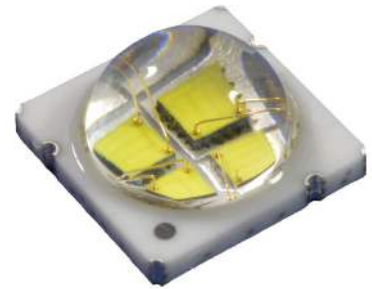

Applications

- Architecture
- Downlights/Spotlights
- Hospitality
- Stage Lighting (LED & Laser)
- Video Walls Signage

Features

- Package: Ceramic package with integrated glass lens
- Chip technology: UX:3
- Typ. Radiation: 90°
- Color: Cx = 0.335, Cy = 0.34 acc. to CIE 1931 (● cool white); Cx = 0.38, Cy = 0.38 acc. to CIE 1931 (● neutral white); Cx = 0.44, Cy = 0.41 acc. to CIE 1931 (● warm white); Cx = 0.50, Cy = 0.41 acc. to CIE 1931 (● ultra warm white)
- CRI: 75 (typ.); 85 (typ.); 85 (typ.); 82 (typ.)

Ordering Information

Type	Brightness ¹⁾	Ordering Code
LZ4-00W408-0000		Q65113A0602
• cool white	• $\Phi_V = 182 \dots 285 \text{ lm}$ ($I_F = 700 \text{ mA}$)	
• neutral white	• $\Phi_V = 155 \dots 242 \text{ lm}$ ($I_F = 700 \text{ mA}$)	
• warm white	• $\Phi_V = 146 \dots 228 \text{ lm}$ ($I_F = 700 \text{ mA}$)	
• ultra warm white	• $\Phi_V = 105 \dots 164 \text{ lm}$ ($I_F = 700 \text{ mA}$)	

Maximum Ratings

Parameter	Symbol		Values	Values	Values	Values
			• cool white	• neutral white	• warm white	• ultra warm white
Operating Temperature	T_{op}	min.	-40 °C	-40 °C	-40 °C	-40 °C
		max.	150 °C	150 °C	150 °C	150 °C
Storage Temperature	T_{stg}	min.	-40 °C	-40 °C	-40 °C	-40 °C
		max.	150 °C	150 °C	150 °C	150 °C
Junction Temperature ²⁾	T_j	max.	150 °C	150 °C	150 °C	150 °C
Forward Current ²⁾	I_F	max.	1500 mA	1500 mA	1500 mA	1500 mA
Forward Current pulsed $t \leq 10$ ms; $D \leq 0.1$; $T_C = 25$ °C	$I_{F pulse}$	max.	1500 mA	1500 mA	1500 mA	1500 mA
ESD withstand voltage acc. ANSI/ESDA/JEDEC JS-001 (HBM, Class 0)	V_{ESD}		ESD sensitive device	ESD sensitive device	ESD sensitive device	ESD sensitive device
Reverse voltage ³⁾	V_R		Not designed for reverse operation	Not designed for reverse operation	Not designed for reverse operation	Not designed for reverse operation

Characteristics

$I_F = 700 \text{ mA}$; $T_C = 25 \text{ °C}$

Parameter	Symbol		Values	Values	Values	Values
			• cool white	• neutral white	• warm white	• ultra warm white
Chromaticity Coordinate ⁴⁾	C_x	typ.	0.335	0.38	0.44	0.50
	C_y	typ.	0.34	0.38	0.41	0.41
Luminous Flux ⁵⁾	Φ_V	typ.	240 lm	190 lm	170 lm	140 lm
Viewing angle at 50% I_V	2ϕ	typ.	95 °	95 °	95 °	95 °
Forward Voltage ⁶⁾⁵⁾ $I_F = 700 \text{ mA}$	V_F	min.	2.8 V	2.8 V	2.8 V	2.8 V
		typ.	3.4 V	3.4 V	3.4 V	3.4 V
		max.	3.8 V	3.8 V	3.8 V	3.8 V
Reverse current ³⁾	I_R		Not designed for reverse operation	Not designed for reverse operation	Not designed for reverse operation	Not designed for reverse operation
Color Rendering Index ⁷⁾	R_a	typ.	75	82	85	85
Electrical thermal resistance junction/case Value in the first column relates to full package with all chips operated simultaneously.	$R_{thJC \text{ elec.}}$	typ.	2.8 K / W			

Brightness Groups

- cool white

Group	Luminous Flux ¹⁾ $I_F = 700 \text{ mA}$ min. Φ_V	Luminous Flux ¹⁾ $I_F = 700 \text{ mA}$ max. Φ_V
PQ	182 lm	285 lm

Brightness Groups

- neutral white

Group	Luminous Flux ¹⁾ $I_F = 700 \text{ mA}$ min. Φ_V	Luminous Flux ¹⁾ $I_F = 700 \text{ mA}$ max. Φ_V
18W	155 lm	242 lm

Brightness Groups

- warm white

Group	Luminous Flux ¹⁾ $I_F = 700 \text{ mA}$ min. Φ_V	Luminous Flux ¹⁾ $I_F = 700 \text{ mA}$ max. Φ_V
19W	146 lm	228 lm

Brightness Groups

- ultra warm white

Group	Luminous Flux ¹⁾ $I_F = 700 \text{ mA}$ min. Φ_V	Luminous Flux ¹⁾ $I_F = 700 \text{ mA}$ max. Φ_V
20W	105 lm	164 lm

Chromaticity Coordinate Groups

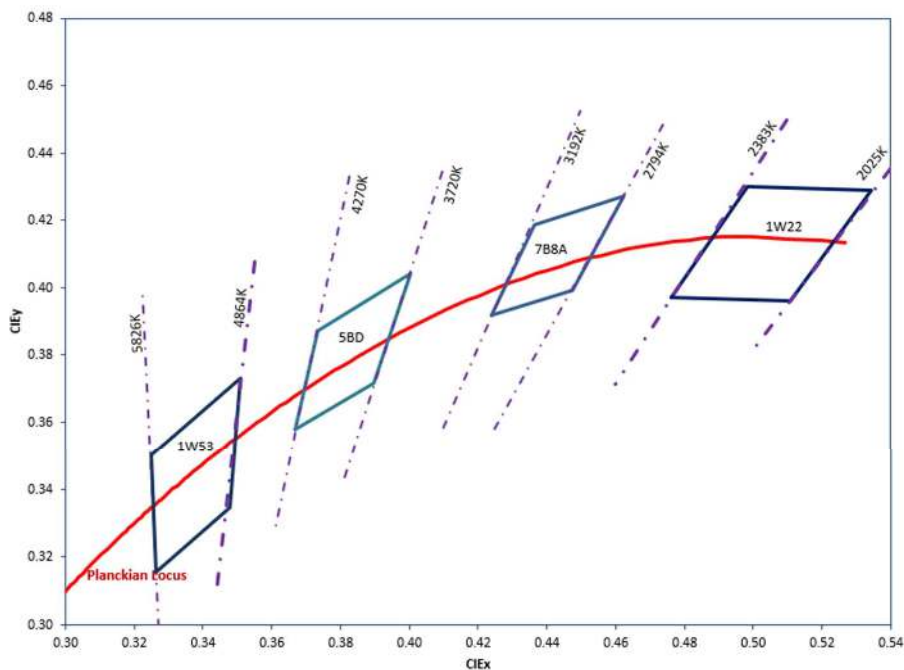

Chromaticity Coordinate Groups ⁴⁾

- cool white

Group	Cx	Cy
1W53	0.3248	0.3500
	0.3511	0.3733
	0.3477	0.3345
	0.3265	0.3154

Chromaticity Coordinate Groups ⁴⁾

- neutral white

Group	Cx	Cy
5BD	0.3670	0.3578
	0.3736	0.3874
	0.4006	0.4044
	0.3898	0.3716

Chromaticity Coordinate Groups ⁴⁾

- warm white

Group	Cx	Cy
7B8A	0.4242	0.3919
	0.4364	0.4188
	0.4624	0.4274
	0.4475	0.3994

Chromaticity Coordinate Groups ⁴⁾

- ultra warm white

Group	Cx	Cy
1W22	0.4765	0.3972
	0.4985	0.4302
	0.5347	0.4289
	0.5110	0.3962

Relative Spectral Emission ⁵⁾

$I_{rel} = f(\lambda); I_F = 700 \text{ mA}; T_C = 25 \text{ }^\circ\text{C}$

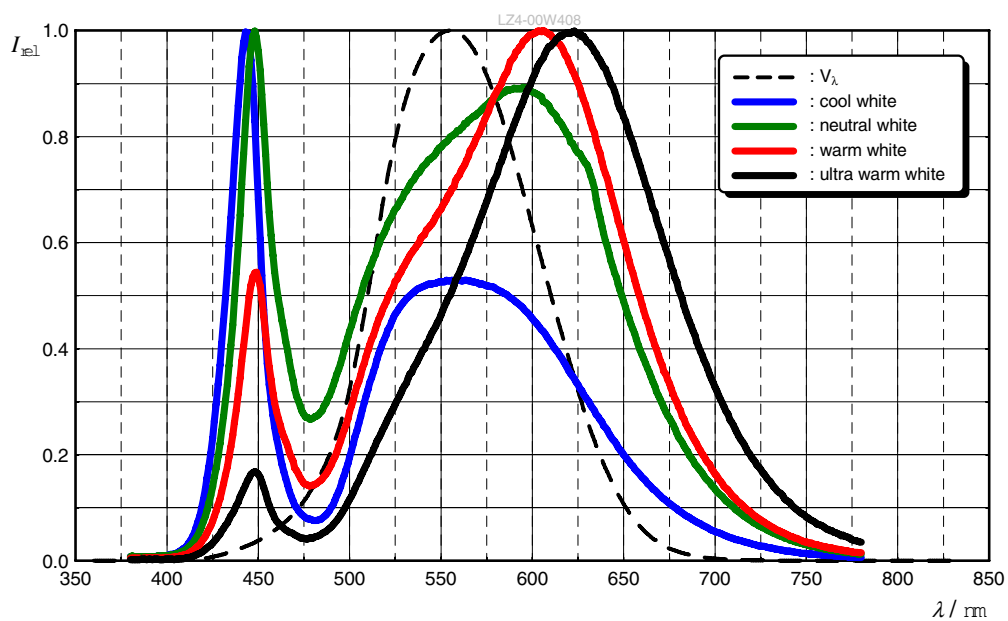

Radiation Characteristics ⁵⁾

$I_{rel} = f(\phi); T_C = 25 \text{ }^\circ\text{C}$

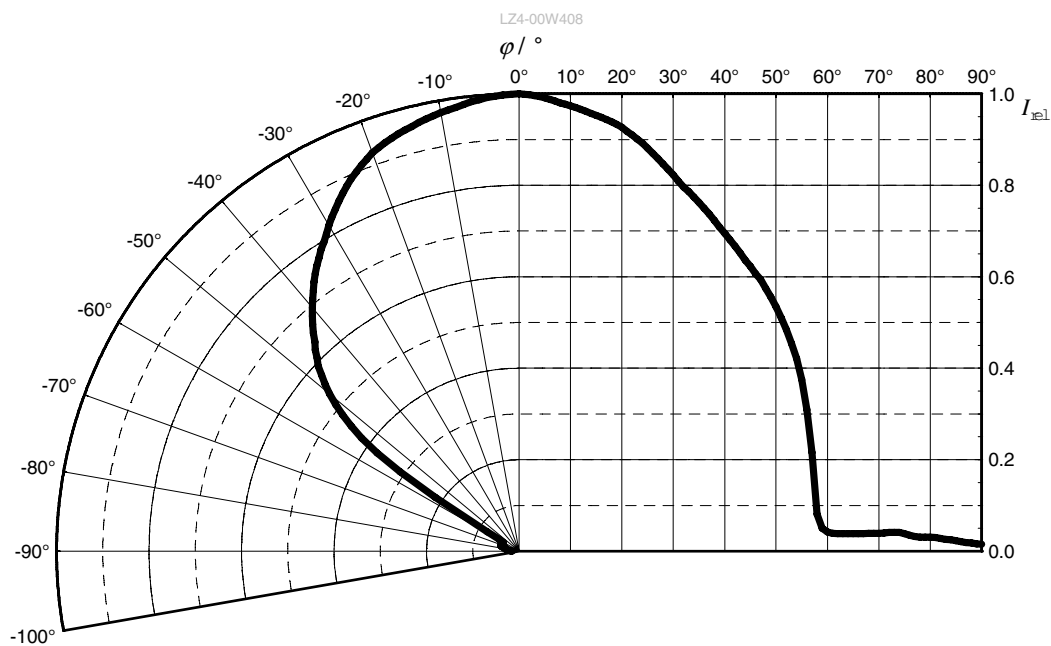

Forward current ⁵⁾

$I_F = f(V_F); T_C = 25\text{ °C}$

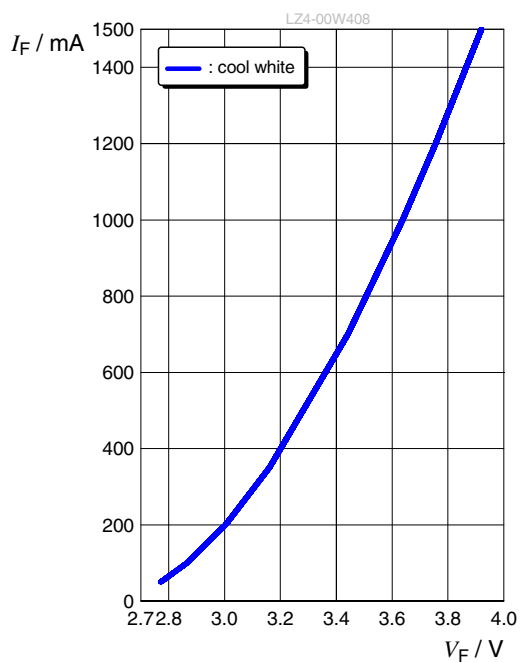

Forward current ⁵⁾

$I_F = f(V_F); T_C = 25\text{ °C}$

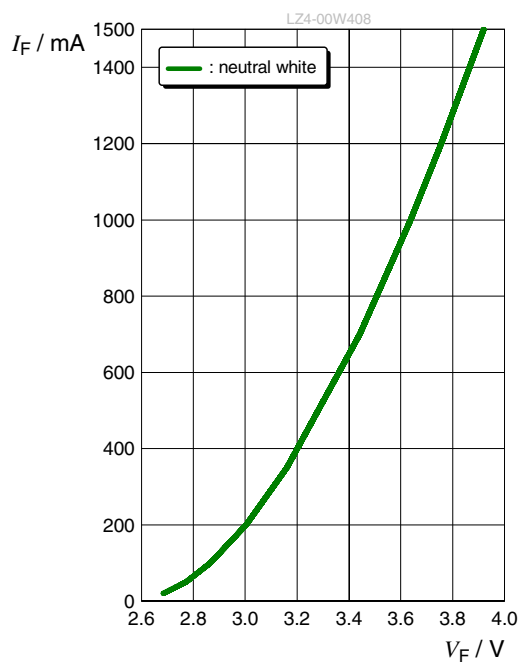

Forward current ⁵⁾

$I_F = f(V_F); T_C = 25\text{ °C}$

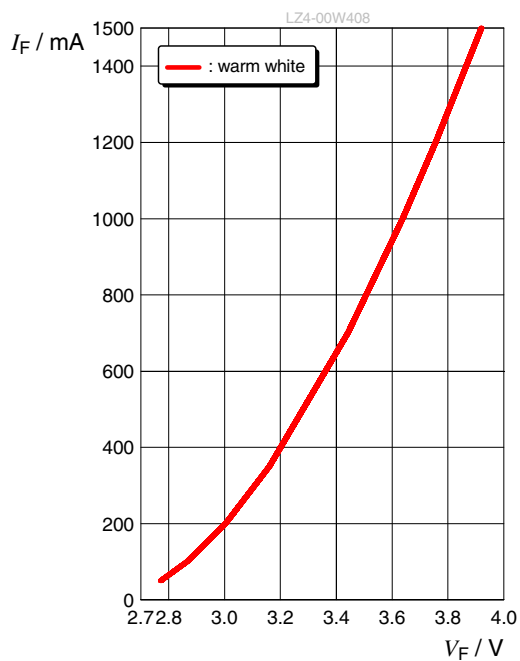

Forward current ⁵⁾

$I_F = f(V_F); T_C = 25\text{ °C}$

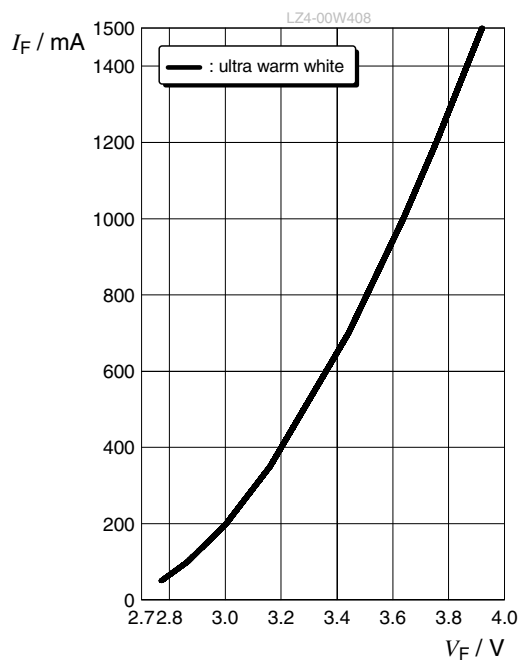

Relative Luminous Flux ^{5), 8)}

$$\Phi_V / \Phi_V(700 \text{ mA}) = f(I_F); T_C = 25 \text{ }^\circ\text{C}$$

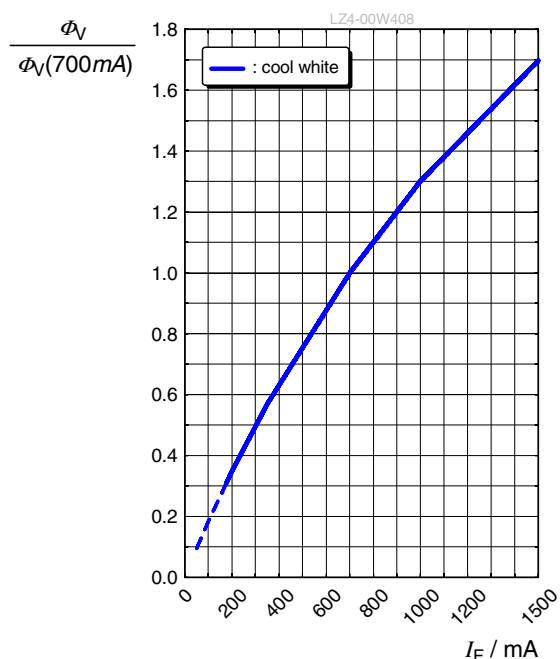

Relative Luminous Flux ^{5), 8)}

$$\Phi_V / \Phi_V(700 \text{ mA}) = f(I_F); T_C = 25 \text{ }^\circ\text{C}$$

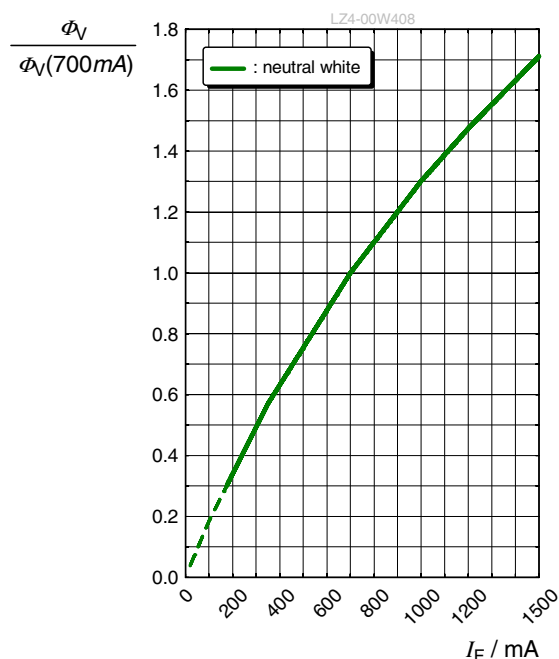

Relative Luminous Flux ^{5), 8)}

$$\Phi_V / \Phi_V(700 \text{ mA}) = f(I_F); T_C = 25 \text{ }^\circ\text{C}$$

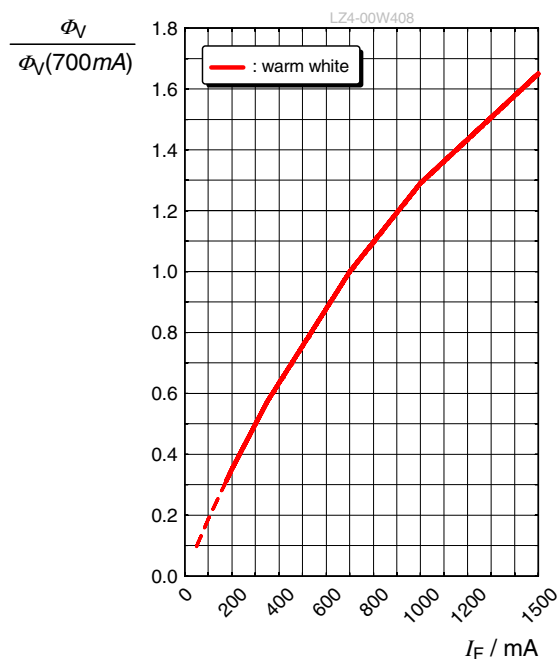

Relative Luminous Flux ^{5), 8)}

$$\Phi_V / \Phi_V(700 \text{ mA}) = f(I_F); T_C = 25 \text{ }^\circ\text{C}$$

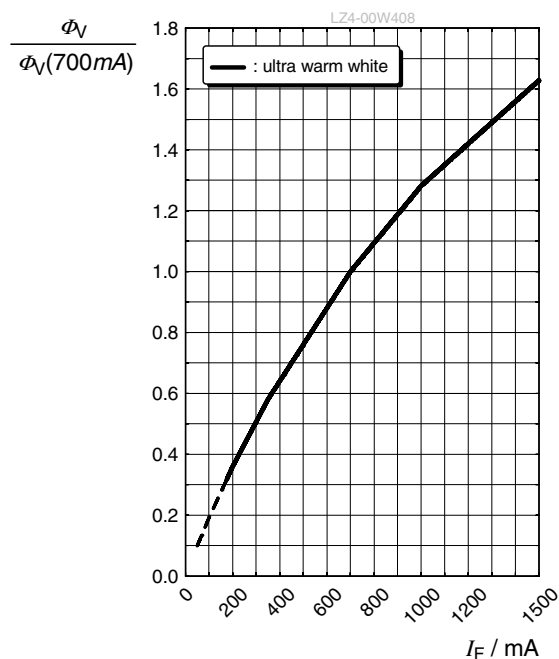

Chromaticity Coordinate Shift ⁵⁾

$\Delta Cx, \Delta Cy = f(I_F); T_C = 25\text{ }^\circ\text{C}$

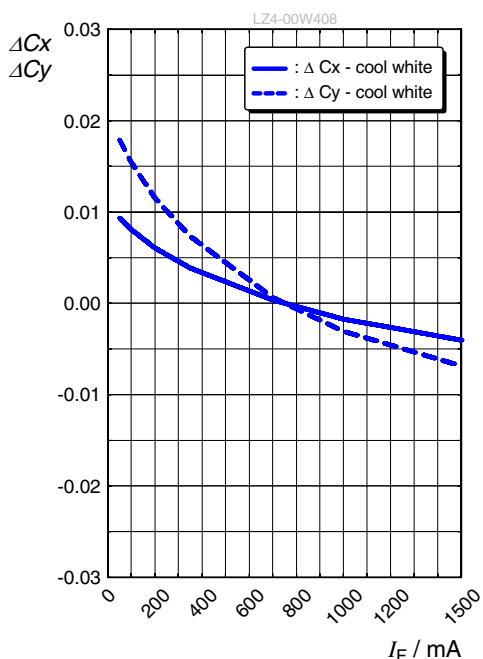

Chromaticity Coordinate Shift ⁵⁾

$\Delta Cx, \Delta Cy = f(I_F); T_C = 25\text{ }^\circ\text{C}$

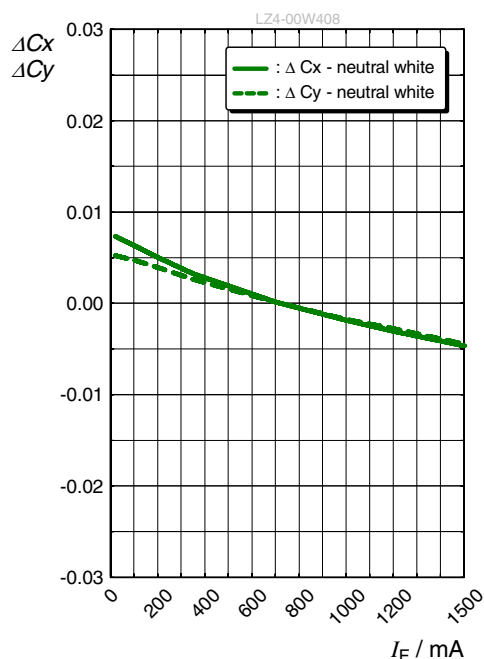

Chromaticity Coordinate Shift ⁵⁾

$\Delta Cx, \Delta Cy = f(I_F); T_C = 25\text{ }^\circ\text{C}$

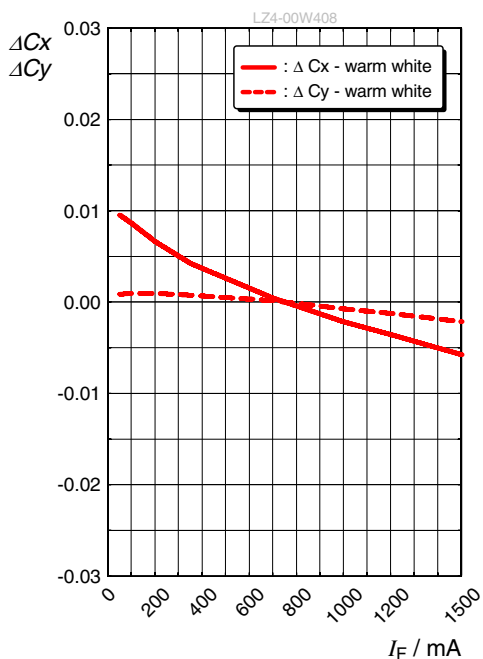

Chromaticity Coordinate Shift ⁵⁾

$\Delta Cx, \Delta Cy = f(I_F); T_C = 25\text{ }^\circ\text{C}$

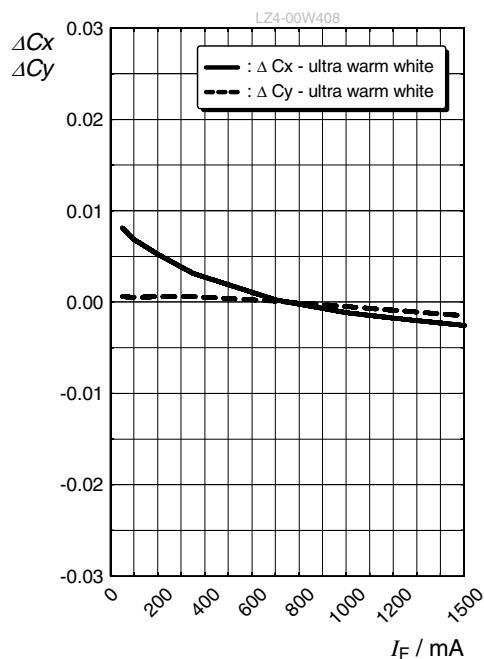

Forward Voltage ⁵⁾

$$\Delta V_F = V_F - V_F(25\text{ }^\circ\text{C}) = f(T_j); I_F = 700\text{ mA}$$

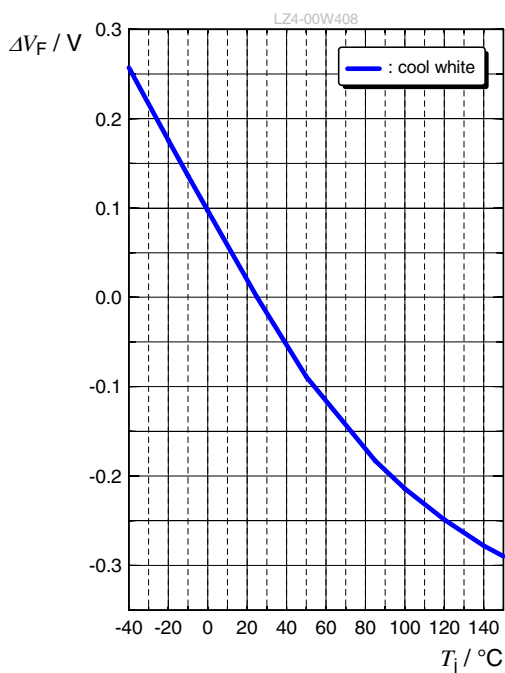

Forward Voltage ⁵⁾

$$\Delta V_F = V_F - V_F(25\text{ }^\circ\text{C}) = f(T_j); I_F = 700\text{ mA}$$

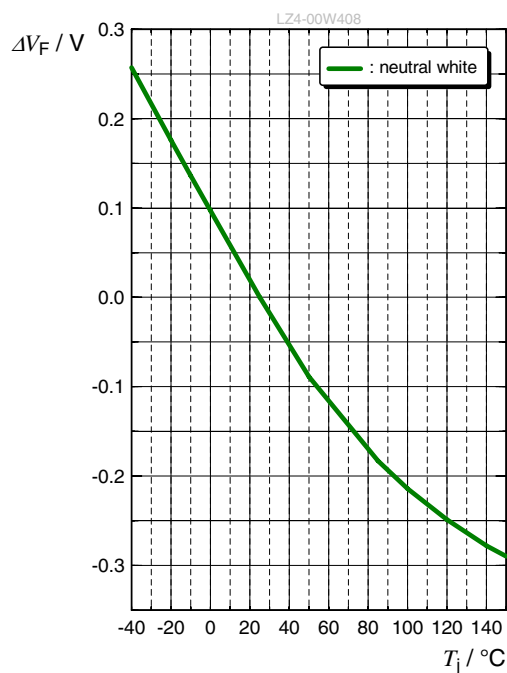

Forward Voltage ⁵⁾

$$\Delta V_F = V_F - V_F(25\text{ }^\circ\text{C}) = f(T_j); I_F = 700\text{ mA}$$

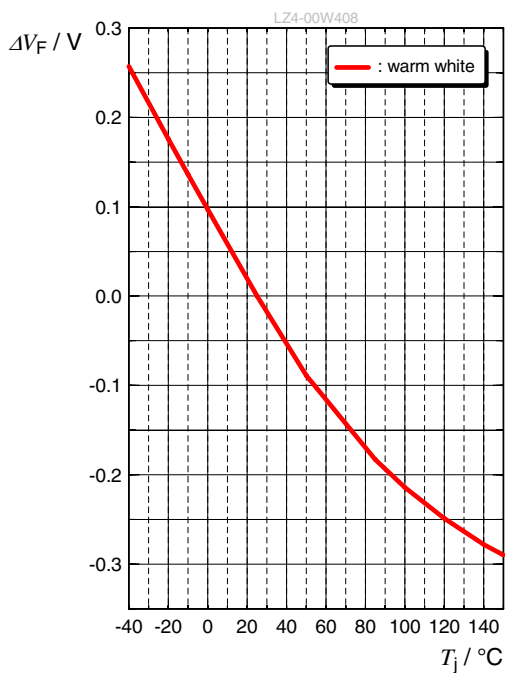

Forward Voltage ⁵⁾

$$\Delta V_F = V_F - V_F(25\text{ }^\circ\text{C}) = f(T_j); I_F = 700\text{ mA}$$

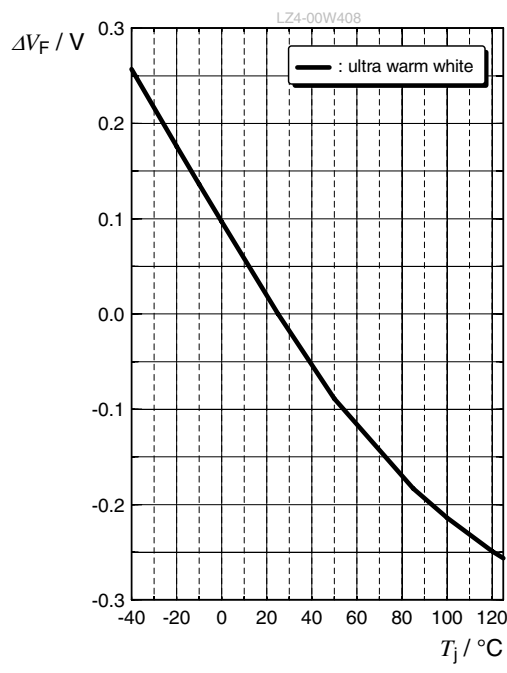

Relative Luminous Flux ⁵⁾

$$\Phi_V / \Phi_V(25^\circ\text{C}) = f(T_j); I_F = 700\text{ mA}$$

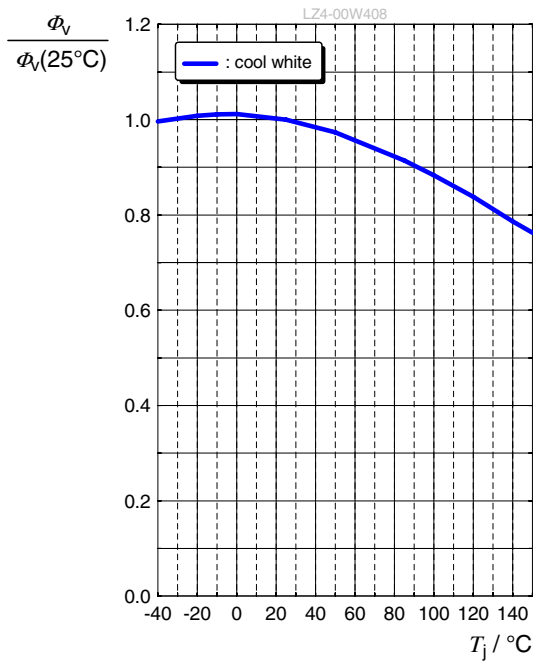

Relative Luminous Flux ⁵⁾

$$\Phi_V / \Phi_V(25^\circ\text{C}) = f(T_j); I_F = 700\text{ mA}$$

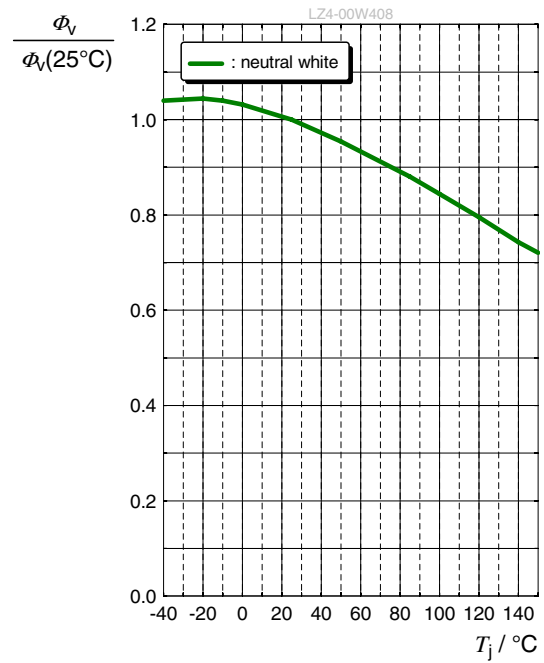

Relative Luminous Flux ⁵⁾

$$\Phi_V / \Phi_V(25^\circ\text{C}) = f(T_j); I_F = 700\text{ mA}$$

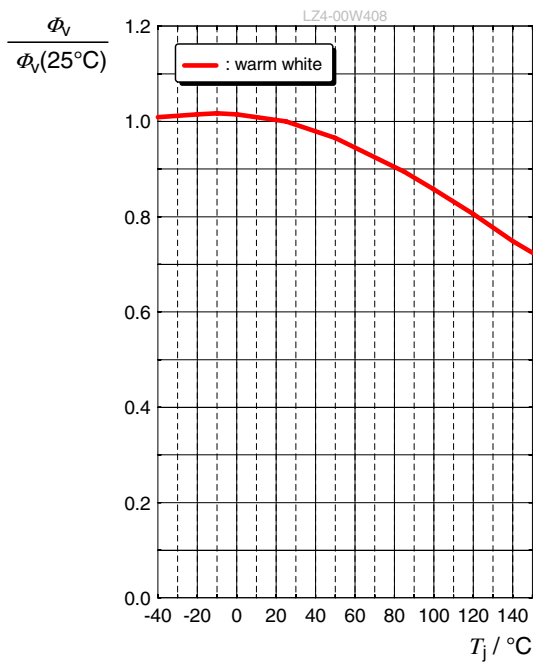

Relative Luminous Flux ⁵⁾

$$\Phi_V / \Phi_V(25^\circ\text{C}) = f(T_j); I_F = 700\text{ mA}$$

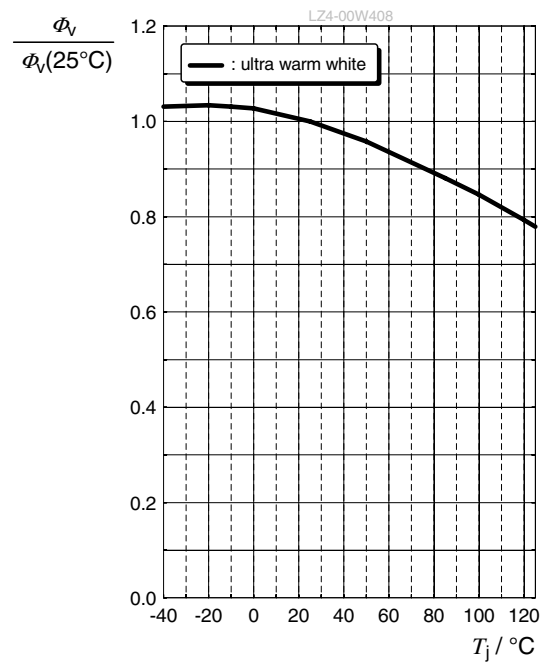

Chromaticity Coordinate Shift ⁵⁾

$\Delta Cx, \Delta Cy = f(T_j); I_F = 700 \text{ mA}$

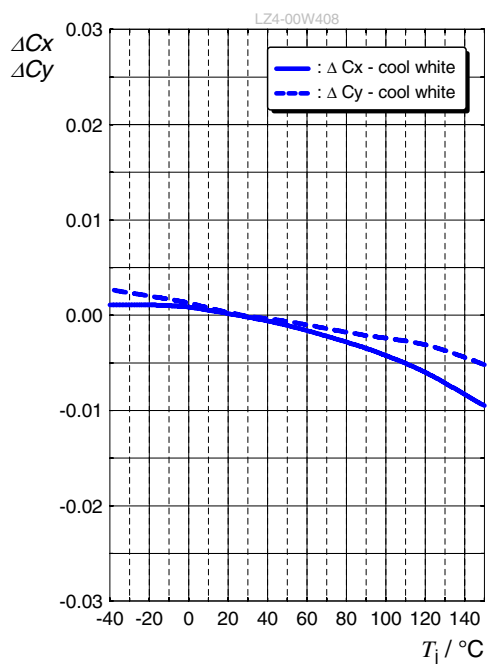

Chromaticity Coordinate Shift ⁵⁾

$\Delta Cx, \Delta Cy = f(T_j); I_F = 700 \text{ mA}$

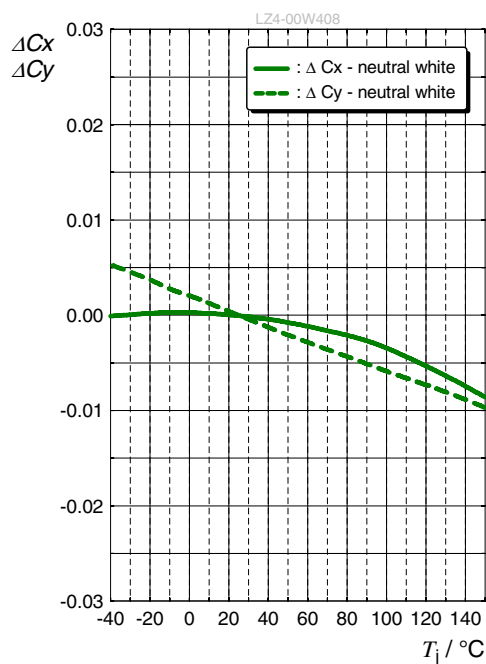

Chromaticity Coordinate Shift ⁵⁾

$\Delta Cx, \Delta Cy = f(T_j); I_F = 700 \text{ mA}$

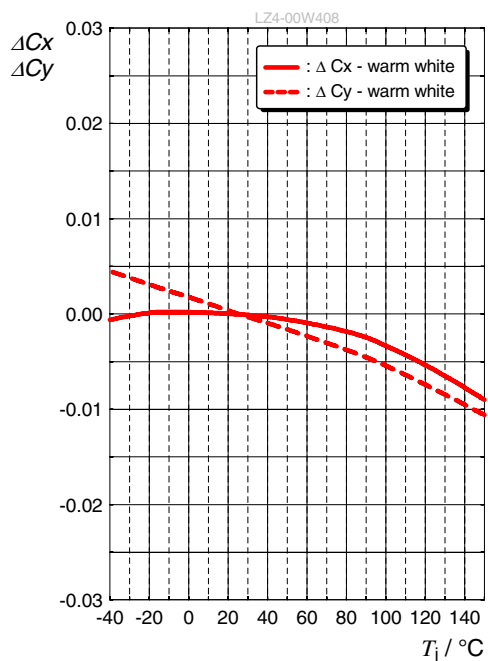

Chromaticity Coordinate Shift ⁵⁾

$\Delta Cx, \Delta Cy = f(T_j); I_F = 700 \text{ mA}$

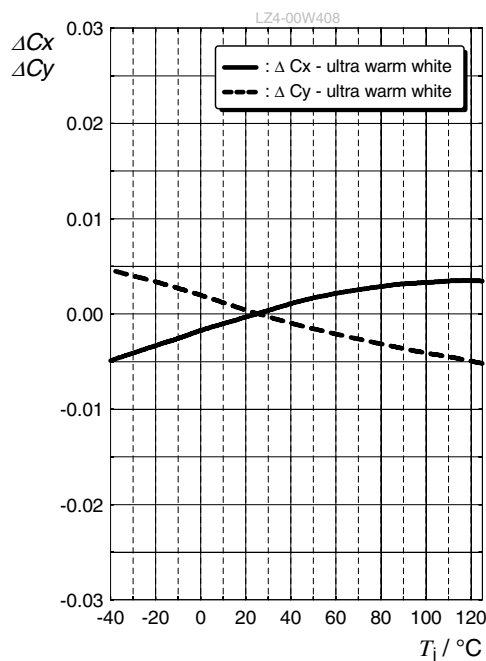

Max. Permissible Forward Current

$I_F = f(T)$; • cool white

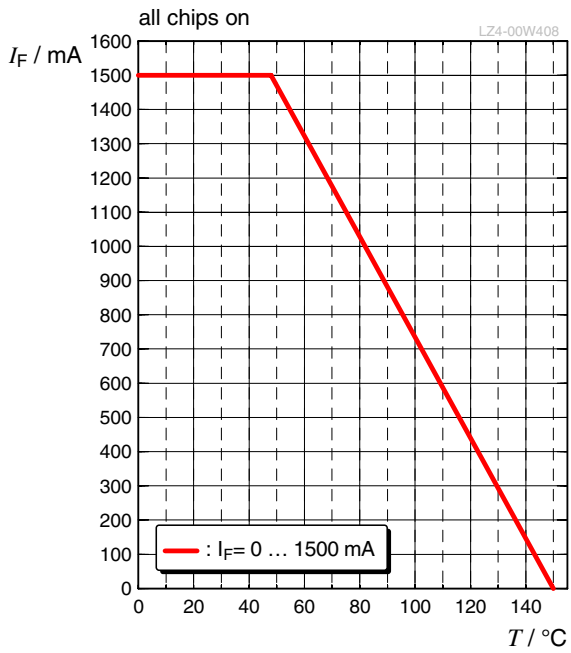

Dimensional Drawing ⁹⁾

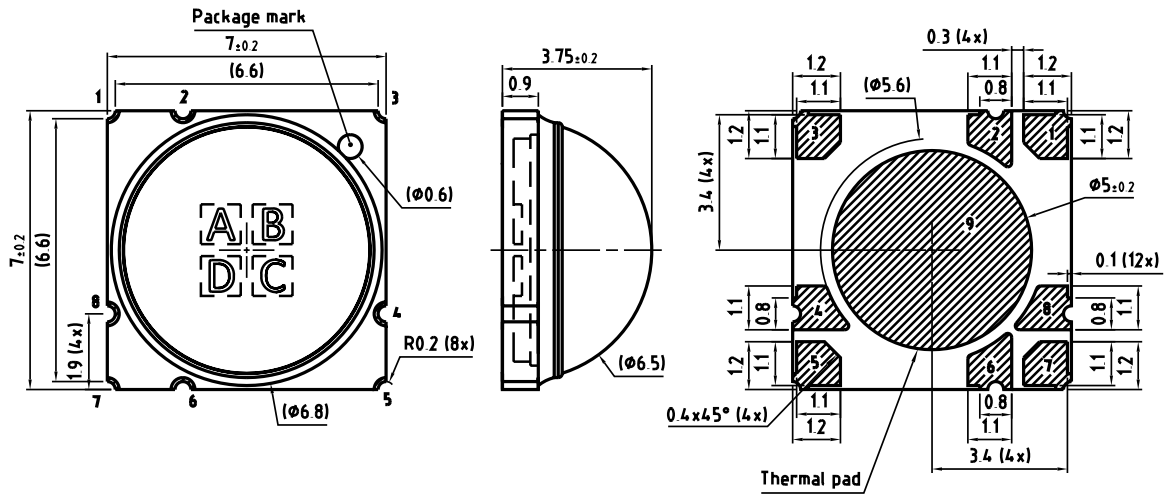

General tolerance ±0.1

Pad finish silver 

C67062-A0375-A18..-01

Further Information:

Approximate Weight: 263.0 mg

Electrical Internal Circuit

Pin Out		
Pad	Die	Function
1	A	Anode
2	A	Cathode
3	B	Anode
4	B	Cathode
5	C	Anode
6	C	Cathode
7	D	Anode
8	D	Cathode
9	n/a	Thermal

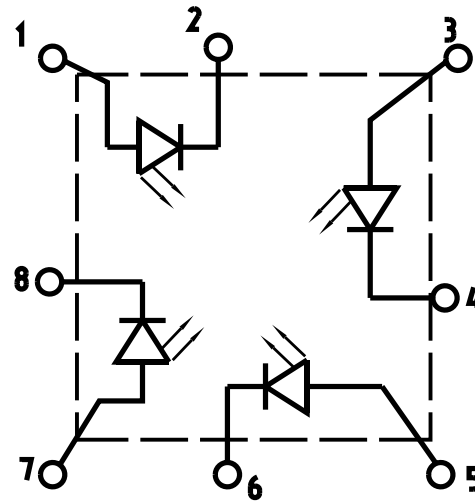

Pin	Description
1, 2	Die A - warm white 3000 K
3, 4	Die B - neutral white 4000 K
5, 6	Die C - ultra warm white 2200 K
7, 8	Die D - cool white 5300 K

Recommended Solder Pad ⁹⁾

Non-pedestal MCPCB Design

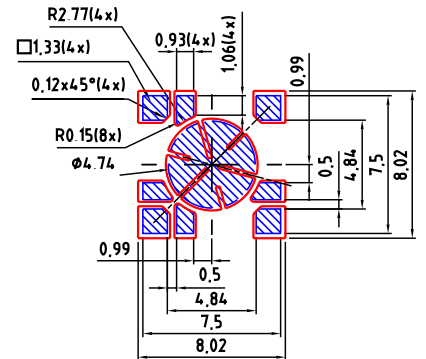
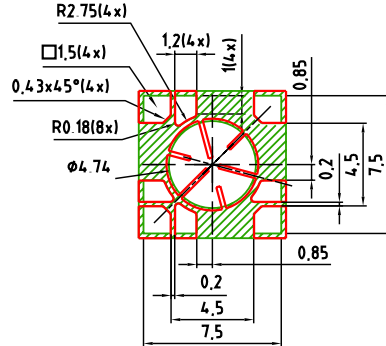
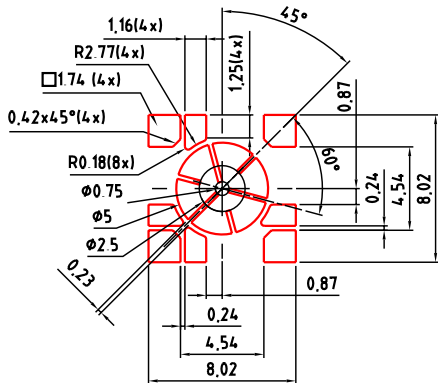

Pedestal MCPCB Design

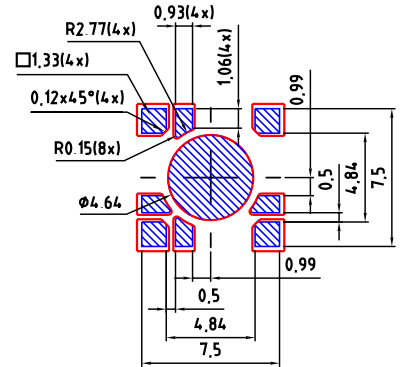
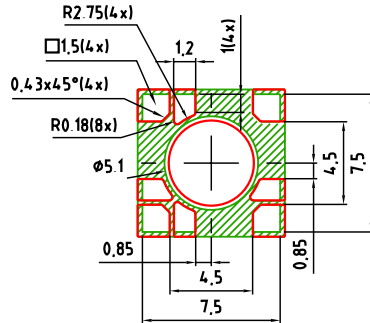
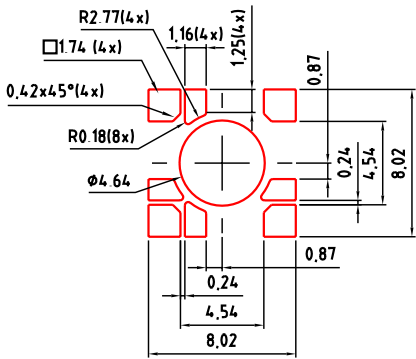

□ foot print

■ solder resist

■ solder stencil
recommended stencil
thickness 200µm

Component Location on Pad

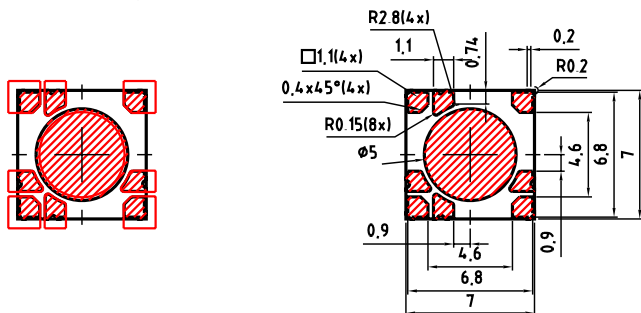

E062.3010.291-01

1. For superior solder joint connectivity results we recommend soldering under standard nitrogen atmosphere.
2. Package not suitable for ultra sonic cleaning.
3. Pedestal MCPCB allows the emitter thermal slug to be soldered directly to the metal core of the MCPCB. Such MCPCB eliminate the high thermal resistance dielectric layer that standard MCPCB technologies use in between the emitter thermal slug and the metal core of the MCPCB, thus lowering the overall system thermal resistance.
4. X-ray sample monitoring for solder voids underneath the emitter thermal slug is recommended. The total area covered by solder voids should be less than 20% of the total emitter thermal slug area. Excessive solder voids will increase the emitter to MCPCB thermal resistance and may lead to higher failure rates due to thermal over stress.

Reflow Soldering Profile

Product complies to MSL Level 1 acc. to JEDEC J-STD-020E

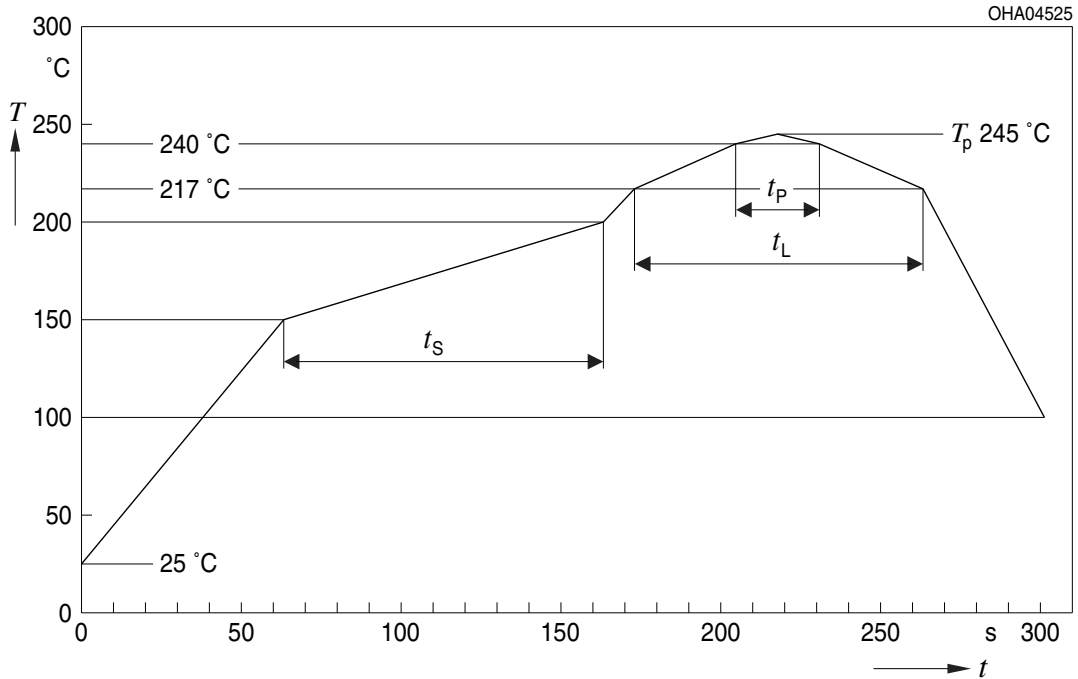

Profile Feature	Symbol	Pb-Free (SnAgCu) Assembly			Unit
		Minimum	Recommendation	Maximum	
Ramp-up rate to preheat ^{*)} 25 °C to 150 °C			2	3	K/s
Time t_s T_{Smin} to T_{Smax}	t_s	60	100	120	s
Ramp-up rate to peak ^{*)} T_{Smax} to T_p			2	3	K/s
Liquidus temperature	T_L		217		°C
Time above liquidus temperature	t_L		80	100	s
Peak temperature	T_p		245	250	°C
Time within 5 °C of the specified peak temperature $T_p - 5$ K	t_p	10	20	30	s
Ramp-down rate* T_p to 100 °C			3	4	K/s
Time 25 °C to T_p				480	s

All temperatures refer to the center of the package, measured on the top of the component
 *) slope calculation DT/Dt : Dt max. 5 s; fulfillment for the whole T-range

Taping ⁹⁾

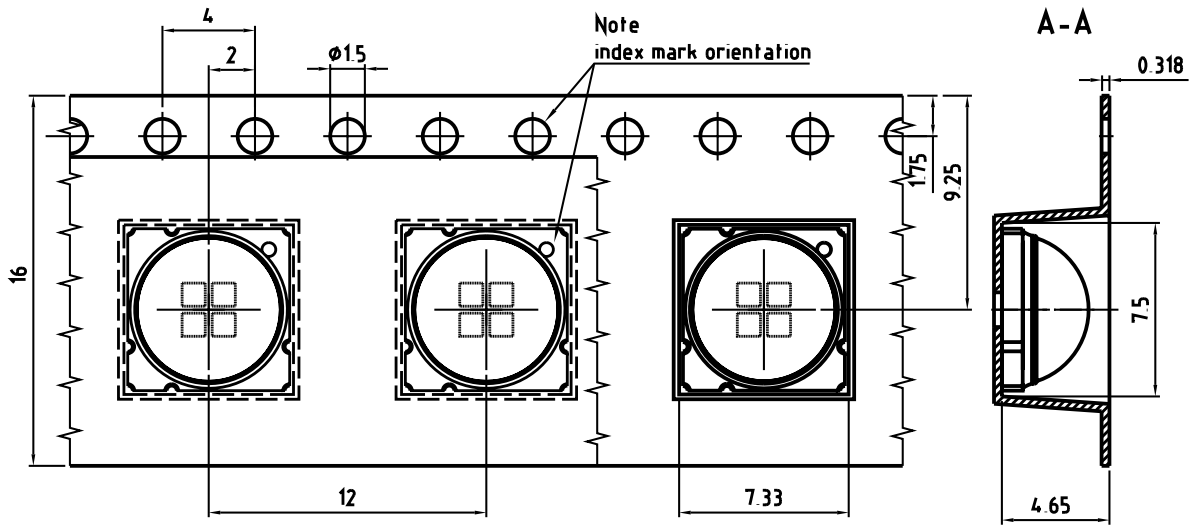

C67062-A0375-B4-01

Tape and Reel ¹⁰⁾

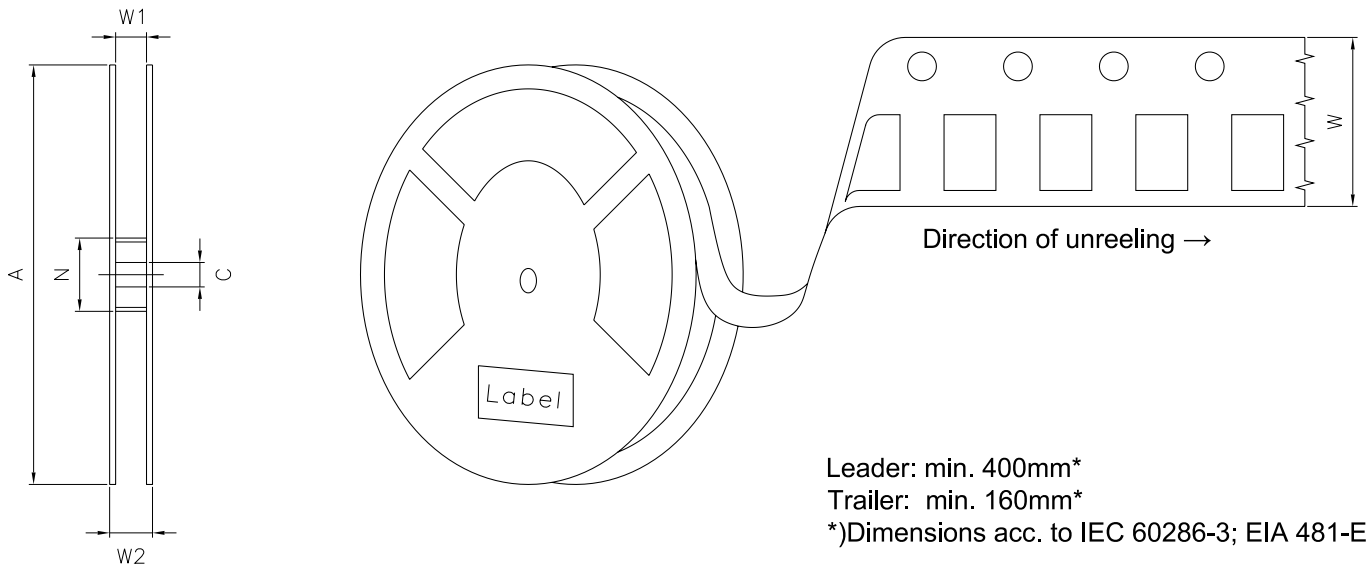

Reel Dimensions

A	W	N _{min}	W ₁	W _{2 max}	Pieces per PU
180 mm	16 + 0.3 / - 0.1 mm	60/100 mm	16.4 + 2 mm	22.4 mm	250

Barcode-Product-Label (BPL)

OSRAM
Opto Semiconductors
Our Brand 
LED ENGINE



(6P) Batch No: 1234567890
(1T) Lot No: 1234567890
(X) Prod No: 12345678
(9D) D/C : 1234
(Q) Qty: 9999
CoO: XX

LXX-XXXXX
XxxXxx
RoHS Compliant

BIN1: XXX-X-X-XXX
BIN2: XXX-X-X-XXX
BIN3: XX-X-X-XXX
BIN4: XXX-XXX-X-XXX
BIN5: X-XX-X-XXX
BIN6: X-XX-X-XXX

ML TEMP ST
X XXX° X

Pack: RXX
B_X123_12345.1234
001



Notes

The evaluation of eye safety occurs according to the standard IEC 62471:2006 (photo biological safety of lamps and lamp systems). Within the risk grouping system of this IEC standard, the device specified in this data sheet fall into the class **moderate risk (exposure time 0.25 s)**. Under real circumstances (for exposure time, conditions of the eye pupils, observation distance), it is assumed that no endangerment to the eye exists from these devices. As a matter of principle, however, it should be mentioned that intense light sources have a high secondary exposure potential due to their blinding effect. When looking at bright light sources (e.g. headlights), temporary reduction in visual acuity and afterimages can occur, leading to irritation, annoyance, visual impairment, and even accidents, depending on the situation.

Subcomponents of this device contain, in addition to other substances, metal filled materials including silver. Metal filled materials can be affected by environments that contain traces of aggressive substances. Therefore, we recommend that customers minimize device exposure to aggressive substances during storage, production, and use. Devices that showed visible discoloration when tested using the described tests above did show no performance deviations within failure limits during the stated test duration. Respective failure limits are described in the IEC60810.

Tapes and reels are shipped in airtight bags in order to reduce the onset of silver tarnish. We recommend bags only be opened when ready to use emitters. Partially used reels or trays should be stored in airtight bags or in storage purged with nitrogen.

Based on very short life cycle times in chip technology this component is subject to frequent adaption to the latest chip technology.

Changes to the content of this datasheet may occur without further notification. JEDEC 46C constitutes the guideline of the change management for the device specified in this document.

For further application related information please visit www.osram-os.com/appnotes

Disclaimer

Attention please!

The information describes the type of component and shall not be considered as assured characteristics. Terms of delivery and rights to change design reserved. Due to technical requirements components may contain dangerous substances.

For information on the types in question please contact our Sales Organization.

If printed or downloaded, please find the latest version on our website.

Packing

Please use the recycling operators known to you. We can also help you – get in touch with your nearest sales office. By agreement we will take packing material back, if it is sorted. You must bear the costs of transport. For packing material that is returned to us unsorted or which we are not obliged to accept, we shall have to invoice you for any costs incurred.

Product and functional safety devices/applications or medical devices/applications

Our components are not developed, constructed or tested for the application as safety relevant component or for the application in medical devices.

Our products are not qualified at module and system level for such application.

In case buyer – or customer supplied by buyer – considers using our components in product safety devices/ applications or medical devices/applications, buyer and/or customer has to inform our local sales partner immediately and we and buyer and /or customer will analyze and coordinate the customer-specific request between us and buyer and/or customer.

Glossary

- 1) **Brightness:** Brightness groups are tested at a current pulse duration of 10 ms and a tolerance of $\pm 10\%$.
- 2) **Operating Conditions:** Operating conditions according DC-derating (Max. Permissible Forward Current)
- 3) **Reverse Operation:** Not designed for reverse operation. Continuous reverse operation can cause migration and damage of the device.
- 4) **Chromaticity coordinate groups:** Chromaticity coordinate groups are tested at a current pulse duration of 10 ms and a tolerance of ± 0.01 .
- 5) **Typical Values:** Due to the special conditions of the manufacturing processes of semiconductor devices, the typical data or calculated correlations of technical parameters can only reflect statistical figures. These do not necessarily correspond to the actual parameters of each single product, which could differ from the typical data and calculated correlations or the typical characteristic line. If requested, e.g. because of technical improvements, these typ. data will be changed without any further notice.
- 6) **Forward Voltage:** Forward voltages are tested at a current pulse duration of 10 ms and a tolerance of ± 0.1 V.
- 7) **Color reproduction index:** Color reproduction index values (CRI-RA) are measured during a current pulse of typically 25 ms, with an internal reproducibility of ± 2 and an expanded uncertainty of ± 3 (acc. to GUM with a coverage factor of $k = 3$).
- 8) **Characteristic curve:** In the range where the line of the graph is broken, you must expect higher differences between single devices within one packing unit.
- 9) **Tolerance of Measure:** Unless otherwise noted in drawing, tolerances are specified with ± 0.1 and dimensions are specified in mm.
- 10) **Tape and Reel:** All dimensions and tolerances are specified acc. IEC 60286-3 and specified in mm.

Revision History

Version	Date	Change
1.1	2022-05-20	New Layout



EU RoHS and China RoHS compliant product

此产品符合欧盟 RoHS 指令的要求；
按照中国的相关法规和标准，
不含有毒有害物质或元素。

Published by ams-OSRAM AG

Tobelbader Strasse 30, 8141 Premstaetten, Austria

Phone +43 3136 500-0

ams-osram.com

© All rights reserved

am 

OSRAM