

RECOMMENDED PANEL CUT OUT DIMENSION

MATING FIGURE(1:1)

- NOTE1. Per Pack : 100 Pieces
 NOTE2. Refer to the technical specification (ETAP-H1021-00) for the packing type.
 3. UL(UL File No. E52653)
 C-UL(UL File No. E52653)
 TUV (Certificate No. R50400864) authorization article.



NO.	UNITS	MATERIAL	FINISH	REMARKS	NO.	PBT	MATERIAL	FINISH	REMARKS
1	mm	2 : 1	1	DIS-H-00004358	1	BLACK, UL94V-0			
Approved : HS. OKAWA Checked : ST. WADA Designed : TT. OHSAKO Drawn : TT. OHSAKO									
Description of Revisions: YK. YAMAGUCHI ST. WADA Date: 20181029									
Drawing No.: EDC-379272-00-00 Part No.: DF60F-3EP-10.16C Code: CL680-4003-0-00									

DF60F IN-LINE TYPE RECOMMENDED PANEL MOUNTING MANUAL (WHEN NUTS USES)

NUT INSTALLATION PROCESS

1. SLIDE A NUT (SIZE:M3) TO NUT FIX PART.

2. PRESS DOWN THE NUT UNTIL IT CLICKS, THEN THIS SOUND MEANS THE NUT HAS INSERTED INTO NUT HOLDER.

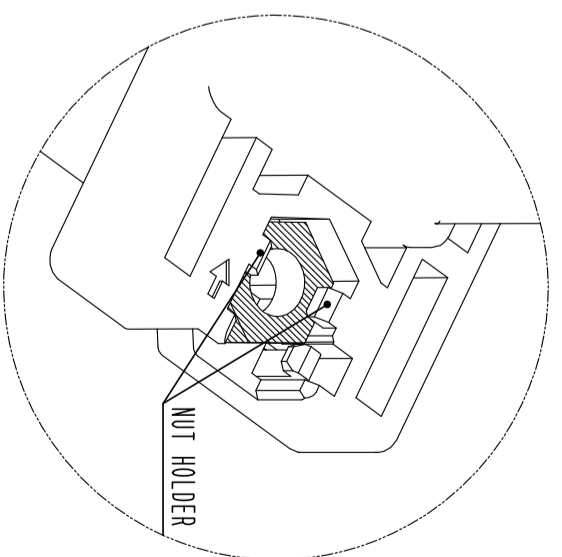
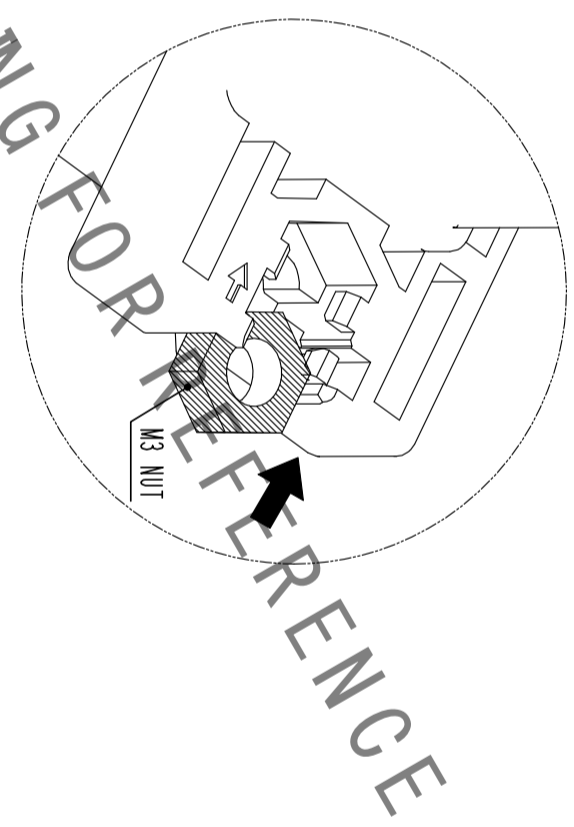
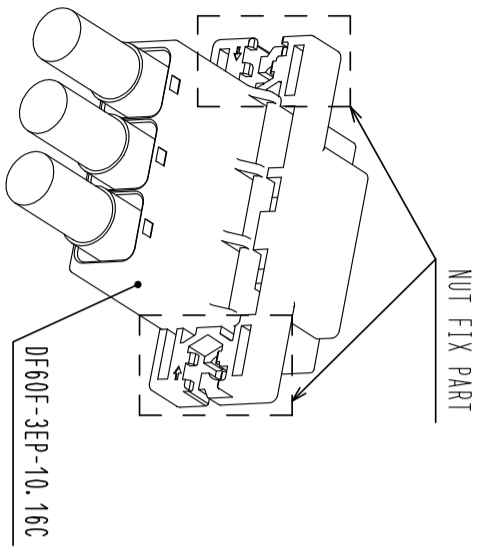

PANEL MOUNTING PROCESS

1. INSERT CONNECTOR INTO PANEL CUT OUT PART.

2. TIGHTEN A SCREW (SIZE:M3) TO FIX WITH PANEL.
RECOMMENDED TORQUE : LESS THAN 0.49N·m

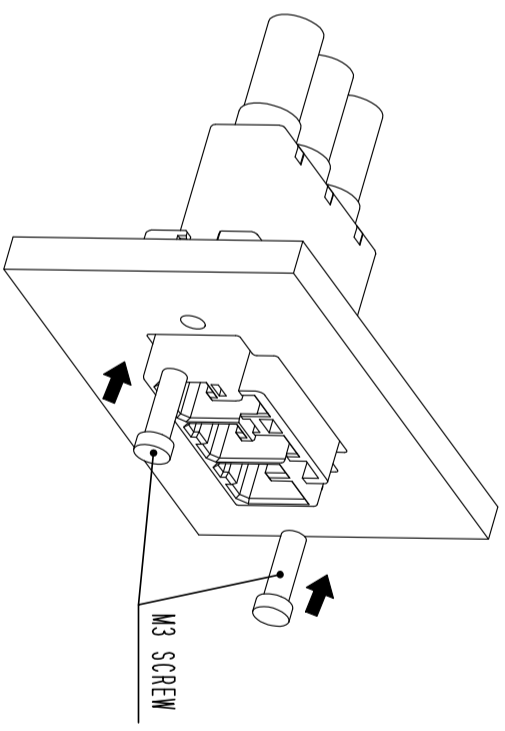
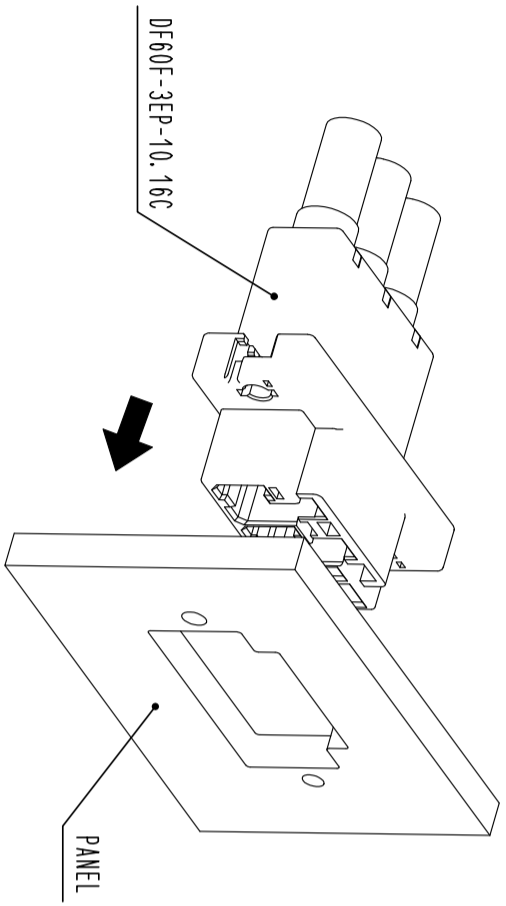

HRS	
DRAWING NO.	EDC-379272-00-00
PART NO.	DF60F-3EP-10.16C
CODE NO.	CL680-4003-0-00
	3/2