

1600W 1U Front End Power Supplies

<https://product.tdk.com/en/power/hfe>
www.emea.lambda.tdk.com/uk/products/hfe



The HFE1600 AC-DC industrial power supplies can be operated in a hot-swap redundant configuration, or used to provide up to 7,600W of bulk power. Up to five power supplies can be fitted in a variety of 19" 1U high racks, for configuration as a single or dual output. The HFE supplies have internal ORing MOSFETs and current share for automatic parallel operation. Communication is possible with the power supplies using the optional isolated PMBus™ (I²C) interface or a plug-in LAN module. AC fail, DC good, remote output adjust, remote on/off and a 12V auxiliary output are fitted as standard.

Features	Benefits
• Internal ORing MOSFET and Current Share	• Suitable For N+1 Redundancy
• Up to 7600W in 1U Rack	• Utilizes Less System Space
• Full Array of Signals Available	• Easy Remote Monitoring
• PMBus™ (I ² C) and LAN options	• Industry Standard Communication Interfaces
• Analog Output Adjustment	• Simple External Resistance or Voltage Connection

Model Selector						
Model	Output Voltage (V)	Adjustment Range (V) ⁽¹⁾	Max Current (A) (Vin>170Vac)	Max Power (W) (Vin>170Vac)	Max Current (A) (100<Vin<170Vac) ⁽²⁾	Max Power (W) (100<Vin<170Vac) ⁽²⁾
HFE1600-12	12	9.6 - 13.2	133	1596	100	1200
HFE1600-24	24	19.2 - 29	67	1608	50	1200
HFE1600-32	32	25.6 - 38.4	47	1500	37.5	1200
HFE1600-48	48	38.4 - 58	33	1584	25	1200

HFE1600-	12	/	S
	Output voltage 12, 24, 32, 48		blank No PMBus™ / I ² C S PMBus™ / I ² C interface

Model Selector (Racks and LAN)		
Model	Description	Maximum Rack Current
HFE1600-S1U	Five slot 19" rack, IEC320-C16 input connectors (5)	266A each side (532A total)
HFE1600-S1U-TB	Five slot 19" rack, terminal block input connectors (5)	266A each side (532A total)
HFE1600/BP	One slot blanking panel, four provided with each rack	-
HFE/C15U	AC Power cord, 2.0m long, one per power supply required	-
HFE1600-D1U	Four slot (two isolated pairs), dual output 19" rack, IEC320 input	266A each side (532A total)
HFE1600-D1U-TB	Four slot (two isolated pairs), dual output 19" rack, terminal block input	266A each side (532A total)
HFE1600-LAN	Plug in LAN module. Takes up one rack slot. For use with /S power supplies only.	-

Specifications					
Model		HFE1600-12	HFE1600-24	HFE1600-32	HFE1600-48
Input					
Input Voltage range (2)	Vac	85 - 265			
Input Frequency	Hz	47 - 63			
Input Current (Max) 115/230Vac	A	14.2 / 8.1			
Inrush Current	A	<35			
Leakage Current	mA	Less than 0.75/1.5mA at 100/230Vac, 60Hz			
Power Factor Correction	-	EN61000-3-2, PF >0.98 at full load			
Harmonic Compliance	-	Meets IEC61000-3-2			
Hold up time	ms	>10ms, 100/230Vac input, 80% loading			
Efficiency (4)	%	87 / 90	88 / 90	88 / 90	89 / 92
Conducted & Radiated EMI	-	EN55022 & FCC part 15; Conducted class B, Radiated class A			
Line Dip	-	Complies with SEMI F47 (200Vac line only)			
Immunity	-	See immunity section			
Safety Certifications and Markings	-	IEC/UL/CSA/EN62368-1, 60950-1, CE Mark and UKCA Mark			

Immunity				
Test	Standard	Test Level	Criteria	Notes
ESD	EN61000-4-2	2,3	B	-
Radiated Susceptibility	EN61000-4-3	2	A	-
Electrical Fast Transient Burst	EN61000-4-4	2	B	-
Surge	EN61000-4-5	3,4	B	-
Conducted Susceptibility	EN61000-4-6	2	A	-
Magnetic Fields	EN61000-4-8	4	A	-
Voltage Dips and Input Interruptions	EN61000-4-11	>95% for 0.5 cycles	B	-
		30% for 25/30 cycles	C	-
		>95% for 250/300 cycles	C	-

Specifications					
Model		HFE1600-12	HFE1600-24	HFE1600-32	HFE1600-48
Output					
Line Regulation	mV	30	60	80	120
Load Regulation	mV	60	120	160	240
External Load Capacitance	uF/A	1000			
Ripple & Noise (1)	mV	240	240	320	480
Temperature Coefficient	%/°C	<0.02			
Minimum Load	-	No minimum load required			
Overcurrent Protection	%	105-120			
Overvoltage Protection (1)	%	110% (Tracking). Cycle AC to reset or utilize Remote On/Off			
Overtemperature Protection (1)	-	Shutdown with automatic reset. Warning signal provided.			
Remote Sense Compensation	V/wire	0.25	0.5	0.75	1.0
Remote On/Off	-	Unit ON: 0-0.6V or short, OFF: 2-15V or open circuit			
Remote Adjust	-	By either external 0-5V signal or 1k ohm potentiometer			
AC Fail Signal	-	Open Collector, ON when AC is within 85-270Vac			
DC Good Signal	-	Open Collector, ON when output is above 85 to 95% of setpoint (tracking)			
Auxiliary Output	-	11.2 - 12.5V, 0.5A, 240mV ripple and noise			
Communication	-	Optional isolated PMBus™ (I ² C) interface (/S suffix) or plug-in LAN module. See model selectors			
Indicators	-	DC OK - Green- >90% ±5% of set output voltage; AC OK - Green - 85 to 270Vac ; Green / Red LED			
Parallel Operation (1)	-	Yes, single wire current share, up to 90% accuracy (load dependant), up to 10 units			

Specifications					
Model		HFE1600-12	HFE1600-24	HFE1600-32	HFE1600-48
Environmental					
Operating Temperature	°C	-10 to +50: 100% load; +50 to +60 derate: 2%/°C of load; +60 to +70 derate: 2.5%/°C of load. For models with reverse air contact factory.			
Storage Temperature	°C	-30 to +85			
Humidity (non condensing)	%RH	Operating: 10 - 90, Storage: 10 - 95			
Cooling	-	Internal variable speed fans. Airflow enters from the front. Contact factory for reverse airflow option.			
Altitude	m	3000 max. Derate output current 2%/100m above 2000m.			
Withstand Voltage	-	I/P to O/P 3kVac, I/P to GND 2kVac. O/P to GND: HFE1600-12, -24V 500Vac, HFE1600-48 2250Vdc 1 min, (POE)			
Isolation Resistance	MΩ	>100 at 25°C, 70%RH & Output to Ground 500Vdc			
Vibration (Non-operating)	-	Meets IEC60068-2-64 (Basic Transportation)			
Shock (Non-operating)	-	Meets IEC60068-2-27 (Basic Transportation)			
Other					
Weight (Typ)	g	Power Supply: 1550, Rack: 4800			
Size (LxWxH)	mm	Power Supply: 300 x 85 x 41; Rack: 365 x 445 x 43.6			
Size (LxWxH)	Inches	Power Supply: 11.8 x 3.35 x 1.61; Rack: 14.4 x 17.5 x 1.72			
PMBus™ / I ² C Interface (1)	-	Isolated from output, Add suffix /S, PMBus™ compatible			
MTBF - Telcordia	Hours	210,143			
Warranty	Years	Three			

Notes

- (1) See installation manual for detailed specifications and test methods
- (2) Derate output power linearly 1%/V from 100Vac to 85Vac input
- (3) Reverse air - contact factory
- (4) At 75% load, 115 / 230Vac input

Outline Drawing HFE1600

FRONT VIEW
 Dimensions: 21.4, 65.0 ± 0.5, 42.2, 22.2 ± 0.2, 40.8 ± 0.3, 30.4

REAR VIEW
 Dimensions: 19.1, 43.0

IN/OUT CONNECTOR REAR VIEW

PIN No.	FUNCTION	PIN No.	FUNCTION
A1 ~ A5	-V OUT	B12	INHIBIT
A6 ~ A10	+V OUT	B13	SCL (PMBus)
B1	SIGNAL RETURN	B14	A1 (PMBus)
B2	PS EXIST	B15	DC OK
B3	AUX. OUT (+12V)	B16	A2 (PMBus)
B4	-SENSE	B17	SDA (PMBus)
B5	A2 (PMBus)	B18	TEMP. ALARM
B6	CURRENT SHARE	B19	V REFERENCE OUT
B7	ENABLE	B20	SMB ALERT (PMBus)
B8	VOLTAGE PROGRAMMING	B21	AC FAIL
B9	+SENSE	C1	CHASSIS GROUND
B10	A3 (PMBus)	C2	AC NEUTRAL
B11	NC	C3	AC LINE

NOTES
 1. CONNECTOR TYPE: FCIM54W13M400A1/A, POSITRONIC.
 2. LED INDICATORS: REFER TO INSTRUCTION MANUAL.
 3. MOUNTING SCREWS MUST NOT PENETRATE MORE THAN 7mm INTO THE UNIT.
 4. LABEL WITH MODEL NAME, INPUT AND OUTPUT RATINGS, SAFETY APPROVAL SYMBOLS AND PLACE FOR DATA CODE AND EU REPRESENTATIVE ADDRESS LABEL.
 5. ALLOW MINIMUM 50mm OF UNRESTRICTED AIR SPACE AT THE REAR OF UNIT. DO NOT OBSTRUCT AIR FLOW TO THE UNIT FRONT PANEL.
 6. REFER TO INSTRUCTION MANUAL FOR SETTING DETAILS.
 7. TO EXTRACT THE POWER SUPPLY, ELEVATE AND HOLD THE RELEASE KNOB AND PULL THE EXTRACTOR HANDLE.

TOLERANCES±

1.16mm	0.1
16.1-63mm	0.2
63.1-250mm	0.3
250.1-1000mm	0.5
ANGLE	±0.3°

Outline Drawing HFE1600-S1U

NOTES
 1. MOUNTING HOLES FOR RACK 19", USE M6x12 SCREWS TO FIX THE UNIT TO A RACK.
 2. USE NUT FLAT WASHER AND SPRING WASHER FOR LOAD WIRES. FINISH: USE LUG FOR STUD M6 FOR LOAD WIRES. RECOMMENDED TORQUE: 43-56 kgf.cm.
 3. TO FIX THE MOUNTING BRACKET TO THE CHASSIS USE M5x10 SCREWS. RECOMMENDED TIGHTENING TORQUE 27-31 kgf.cm. SCREWS MUST NOT PENETRATE THE CHASSIS MORE THAN 6.0mm.
 4. REFER TO INSTRUCTION MANUAL FOR SETTING DETAILS.
 5. MODEL NAME, VOLTAGE AND CURRENT RATING AND SAFETY APPROVAL SYMBOLS WILL BE SHOWN HERE ACCORDING TO THE SPECIFICATION.
 6. THE HFE-S1U RACK IS SHOWN WITH 5 HFE1600 UNITS INSTALLED.
 7. EU REPRESENTATIVE ADDRESS LABEL
 8. EC 60417-0042 AND EC 60417-0172
 9. SAFETY SYMBOLS LABELS

1	2	3	4	5	6	7	8	9	10	11	12	13	14	15	16	17	18	19	20	21	22	23	24	25	26	27	28	29	30	31	32	33	34	35	36	37	38	39	40
-SENSE	LS	+SENSE	+LS	V_RPOG	TRIM	NC	+SVV_REF (*1)	+SVV_REF (*1)	-SENSE	TEMP_ALM_A	TEMP_ALM_B	TEMP_ALM_C	TEMP_ALM_D	TEMP_ALM_E	AC_FAIL_A	AC_FAIL_B	AC_FAIL_C	AC_FAIL_D	AC_FAIL_E	DC_OK_A	DC_OK_B	DC_OK_C	DC_OK_D	DC_OK_E	SIGNAL RETURN	INHIBIT_A	INHIBIT_B	INHIBIT_C	INHIBIT_D	INHIBIT_E	PS_EXIST_A	PS_EXIST_B	PS_EXIST_C	PS_EXIST_D	PS_EXIST_E	SIGNAL RETURN	+12V_AUX	ENABLE	SIGNAL RETURN

*1. FOR HFE1600-xx/S WITH PMBUS OPTION: V_REF
 FOR HFE1600-xx WITHOUT PMBUS OPTION: 5V

ACCESSORIES LIST IN SHEET 2

Outline Drawing HFE1600-S1U-TB

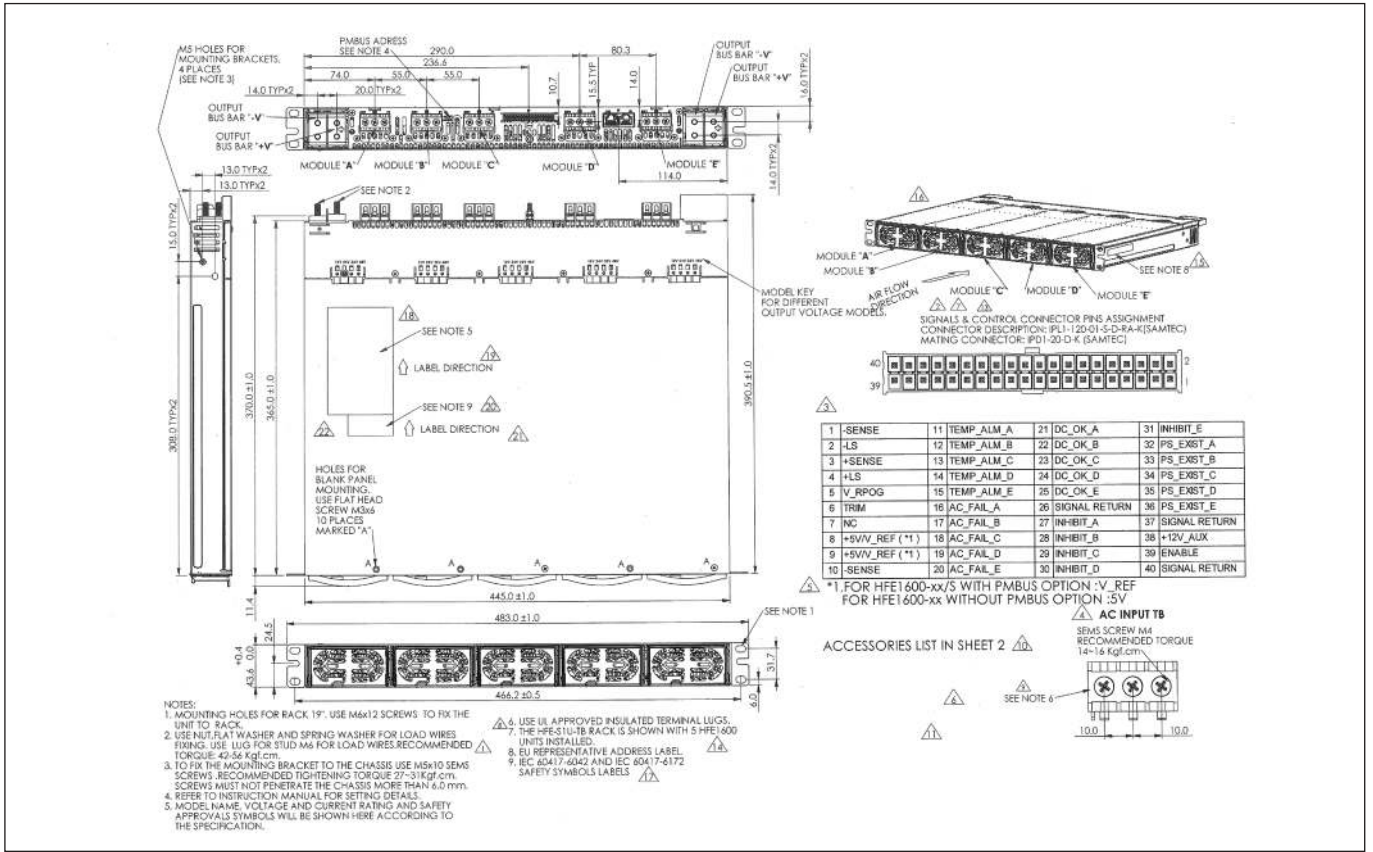

Outline Drawing HFE1600-D1U

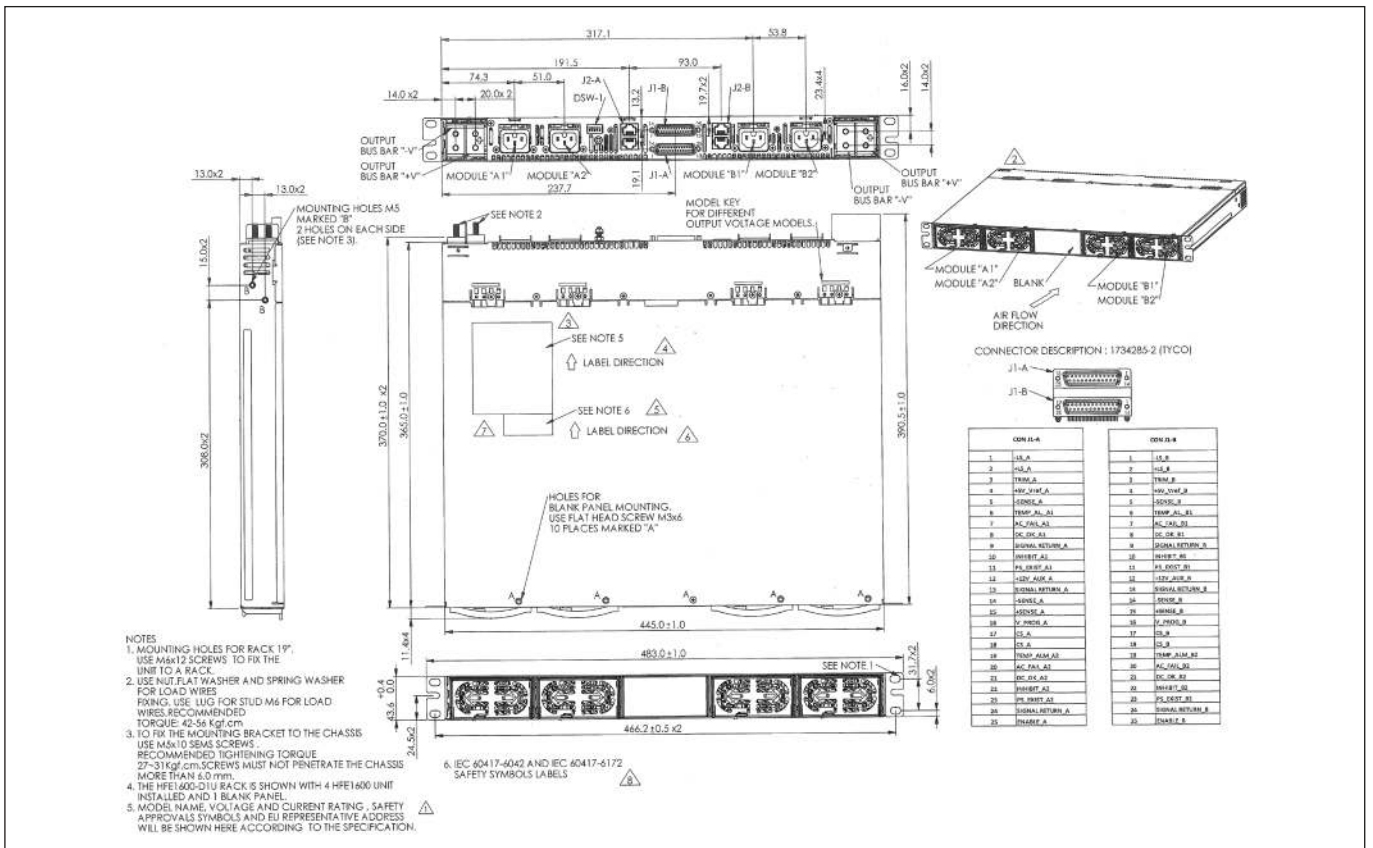

Outline Drawing HFE1600-D1U-TB

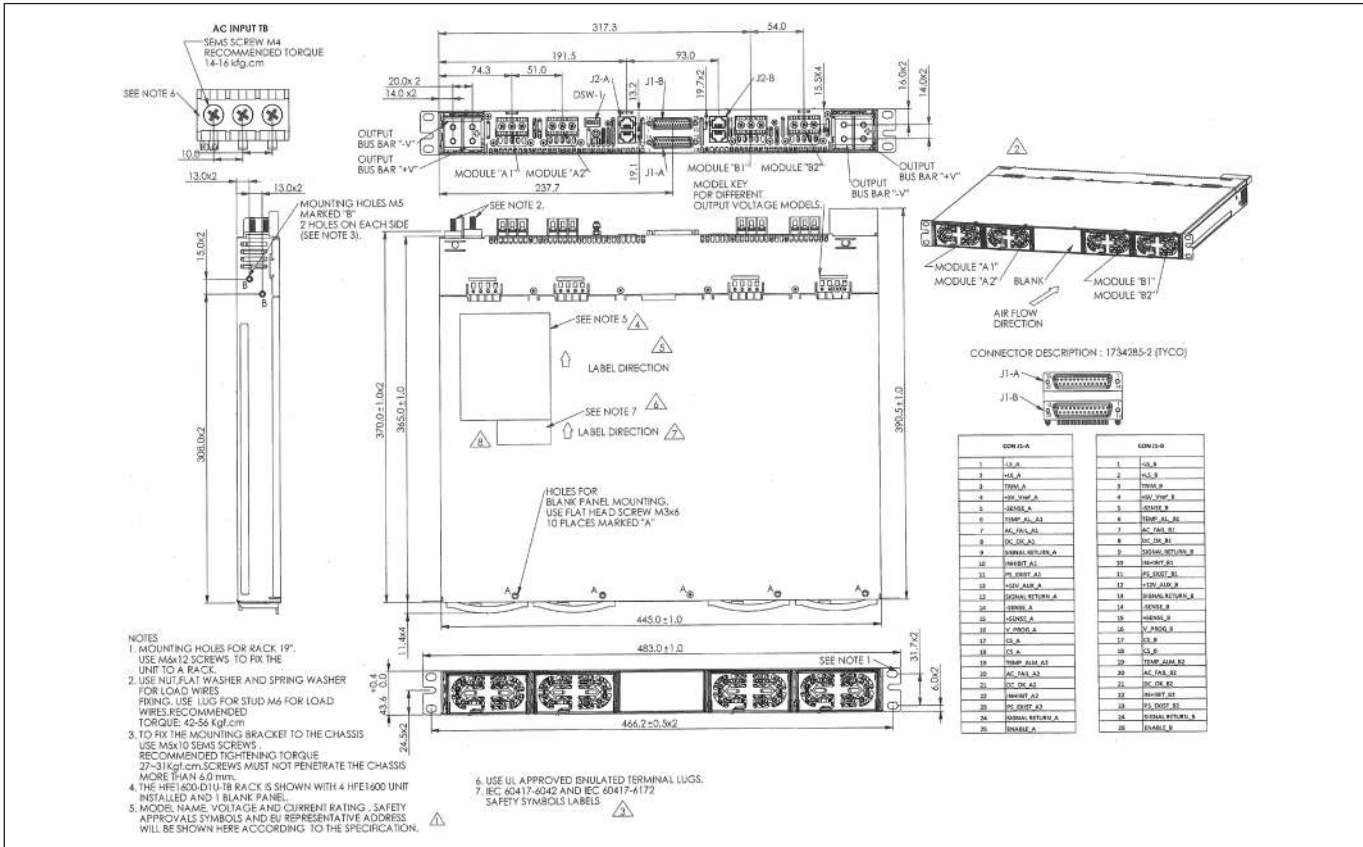

Outline Drawing HFE1600-LAN

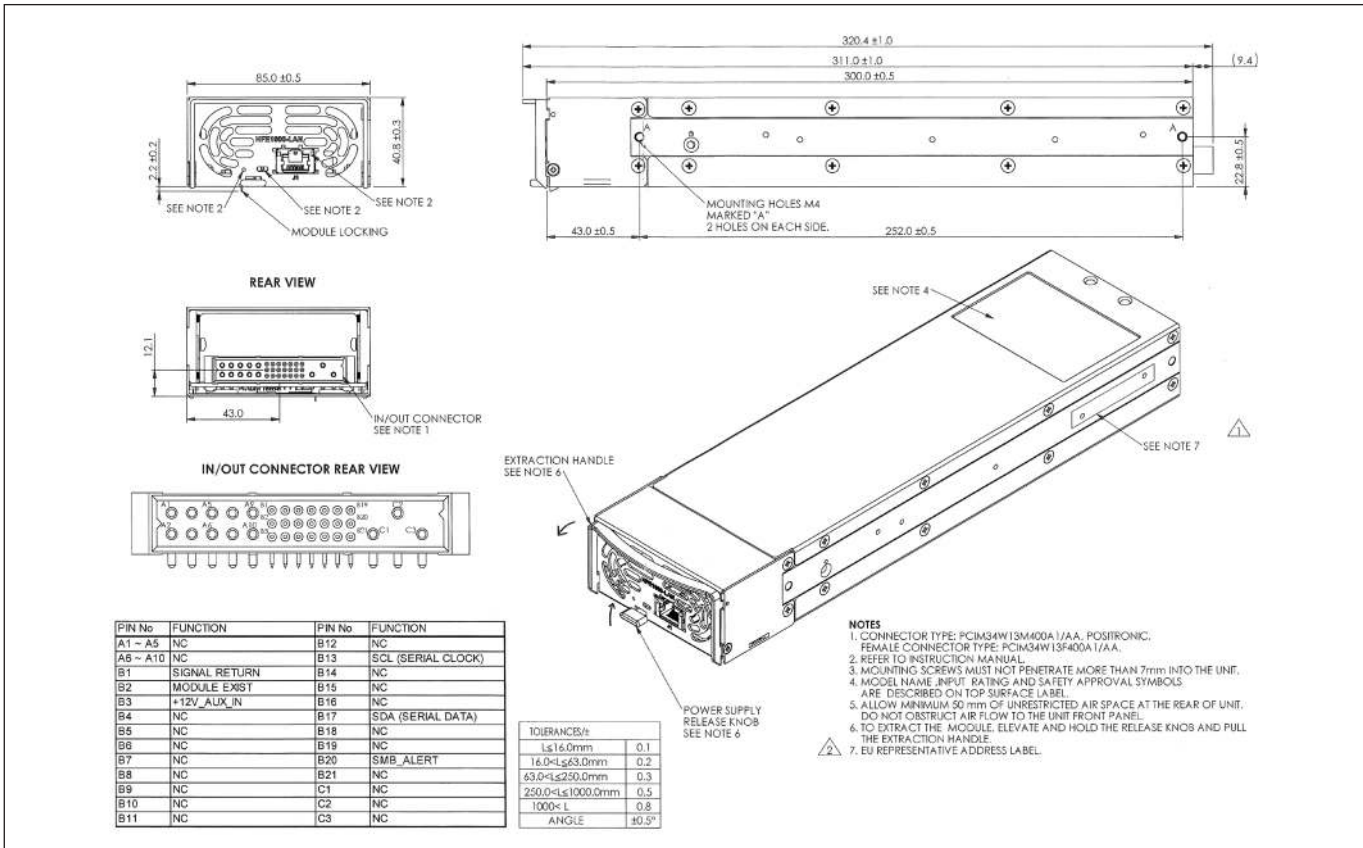



TDK-Lambda France SAS

Tel: +33 1 60 12 71 65
france@fr.tdk-lambda.com
www.emea.lambda.tdk.com/fr



Italy Sales Office

Tel: +39 02 61 29 38 63
info.italia@it.tdk-lambda.com
www.emea.lambda.tdk.com/it



Netherlands

info@nl.tdk-lambda.com
www.emea.lambda.tdk.com/nl



TDK-Lambda Germany GmbH

Tel: +49 7841 666 0
info@de.tdk-lambda.com
www.emea.lambda.tdk.com/de



Austria Sales Office

Tel: +43 2256 655 84
info@at.tdk-lambda.com
www.emea.lambda.tdk.com/at



Switzerland Sales Office

Tel: +41 44 850 53 53
info@ch.tdk-lambda.com
www.emea.lambda.tdk.com/ch



Nordic Sales Office

Tel: +45 8853 8086
info@dk.tdk-lambda.com
www.emea.lambda.tdk.com/dk



TDK-Lambda UK Ltd.

Tel: +44 (0) 12 71 85 66 66
info@uk.tdk-lambda.com
www.emea.lambda.tdk.com/uk



TDK-Lambda Ltd.

Tel: +9 723 902 4333
info@tdk-lambda.co.il
www.emea.lambda.tdk.com/il



C.I.S.

Commercial Support:

Tel: +7 (495) 665 2627

Technical Support:

Tel: +7 (812) 658 0463
info@tdk-lambda.ru
www.emea.lambda.tdk.com/ru



TDK-Lambda Americas

Tel: +1 800-LAMBDA-4 or 1-800-526-2324
powersolutions@us.tdk-lambda.com
www.us.lambda.tdk.com



TDK Electronics do Brasil Ltda

Tel: +55 11 3289-9599
sales.br@tdk-electronics.tdk.com
www.tdk-electronics.tdk.com/en



TDK-Lambda Corporation

Tel: +81-3-6778-1113
www.jp.lambda.tdk.com



TDK-Lambda (China) Electronics Co. Ltd.

Tel: +86 21 6485-0777
powersolutions@cn.tdk-lambda.com
www.lambda.tdk.com.cn



TDK-Lambda Singapore Pte Ltd.

Tel: +65 6251 7211
tts.mkt@sg.tdk-lambda.com
www.sg.lambda.tdk.com



TDK India Private Limited, Power Supply Division

Tel: +91 80 4039-0660
mathew.philip@in.tdk-lambda.com
www.sg.lambda.tdk.com

