

CLASSIFICATION Einstufung	PRODUCT SPECIFICATION Produktspezifikation	No. DS-1x55-2400-102	REV. 1.10
SUBJECT Thema	CLASS 2 BLUETOOTH MODULE Bluetooth Modul der Klasse 2	PAGE Seite	1 of 34
CUSTOMER'S CODE PAN1455/1555	PANASONIC'S CODE ENW89815CxKF/ENW89815AxKF	DATE Datum	27.06.2011

Specification for Production

Applicant / Manufacturer Panasonic Electronic Devices Europe GmbH
Hardware Zeppelinstrasse 19
 21337 Lüneburg
 Germany

Applicant / Manufacturer Stollmann Entwicklungs- und Vertriebs-GmbH
Software Mendelssohnstrasse 15 D
 22761 Hamburg
 Germany

Supported Bluetooth Profiles BlueRS , SPP, HDP, HID, OPP, HDP/SPP

Contents Approval for Mass Production

Customer

By signing this document, you acknowledge that you are the legal representative for your company and that you understand and accept the validity of the contents herein .

CHECKED / APPROVED:

DATE:	NAME:	SIGNATURE:

NOTE:

AT LEAST ONE SET OF APPROVED SPECIFICATIONS SHOULD BE RETURNED TO THE ADDRESS OF THE ISSUING PARTY.

PANASONIC ELECTRONIC DEVICES EUROPE GMBH High Frequency Products Business Group - Wireless Modules -	APPROVED genehmigt	CHECKED geprüft	DESIGNED erstellt
---	-----------------------	--------------------	----------------------

CLASSIFICATION Einstufung	PRODUCT SPECIFICATION Produktspezifikation	No. DS-1x55-2400-102	REV. 1.10
SUBJECT Thema	CLASS 2 BLUETOOTH MODULE Bluetooth Modul der Klasse 2	PAGE Seite	2 of 34
CUSTOMER'S CODE PAN1455/1555	PANASONIC'S CODE ENW89815CxKF/ENW89815AxKF	DATE Datum	27.06.2011

TABLE OF CONTENTS

1.	Key Features.....	4
2.	Applications for the Module.....	4
3.	Description for the Module.....	5
4.	Scope of this Document.....	6
5.	History for this Document.....	6
6.	Terminal Layout.....	7
6.1.	General Pin Assignment.....	8
6.2.	Application Specific Pin Description.....	9
6.2.1.	SPP configuration DCE Mode.....	9
7.	Terminal Specifics.....	10
7.1.	RF-Interface - ANT.....	10
7.2.	Power Supply.....	10
7.3.	Power-On-Reset.....	10
7.4.	UART Interface – TXD, RXD, CTS, RTS.....	11
7.5.	3-wire Serial Interface.....	12
7.6.	USB Interface.....	12
7.6.1.	USB_DP, USB_DN.....	12
7.7.	GPIO Interface.....	12
7.8.	ADC.....	12
7.9.	DAC.....	12
7.10.	PCM Interface.....	12
8.	Key Parts List.....	13
9.	Test Conditions.....	14
10.	Absolute Maximum Ratings ⁽¹⁾	14
11.	Electrical Requirements.....	14
12.	I/O Operating Characteristics.....	15
13.	USB Interface.....	15
14.	Typical Current Consumption.....	16
14.1.	SPP Configuration.....	16
14.1.1.	Deep Sleep State.....	16
14.1.2.	Power Down State.....	16
14.1.3.	Idle State.....	16
14.2.	Power Consumption.....	16
14.3.	Power-up time.....	17
15.	Electrical RF-Characteristics.....	17
16.	Mechanical Requirements.....	18
17.	Soldering Temperature-Time Profile (for reflow soldering).....	19
17.1.	For lead solder.....	19
17.2.	For leadfree solder.....	19

CLASSIFICATION Einstufung	PRODUCT SPECIFICATION Produktspezifikation	No. DS-1x55-2400-102	REV. 1.10
SUBJECT Thema	CLASS 2 BLUETOOTH MODULE Bluetooth Modul der Klasse 2	PAGE Seite	3 of 34
CUSTOMER'S CODE PAN1455/1555	PANASONIC'S CODE ENW89815CxKF/ENW89815AxKF	DATE Datum	27.06.2011

18.	Module Dimension	20
19.	Recommended Foot Pattern	21
20.	Labelling Drawing.....	23
21.	Software	24
	21.1. SPP Software	24
	21.2. HDP Software	24
	21.3. HID Software	24
	21.4. HDP/SPP Software.....	24
	21.5. Other Profiles are available on request.	24
22.	Cautions	24
	22.1. Design Notes	24
	22.2. Installation Notes	25
	22.3. Usage Conditions Notes	25
	22.4. Storage Notes	25
	22.5. Safety Cautions	26
	22.6. Other cautions	27
23.	Packaging	28
	23.1. Embossed tape / Blistergurt.....	28
	23.2. Component direction.....	29
	23.3. Reel dimension	30
	23.4. Package.....	30
24.	Ordering Information	31
25.	RoHS Declaration	31
26.	Data Sheet Status	31
27.	Regulatory Information.....	32
	27.1. FCC Notice	32
	27.2. Caution	32
	27.3. Labeling Requirements.....	32
	27.4. Antenna Warning	33
	27.5. Approved Antenna List	33
	27.6. RF Exposure PAN1455/PAN1555	33
	27.7. Industry Canada Certification	33
28.	Related Documents.....	34
29.	General Information	34
30.	Life Support Policy	34

CLASSIFICATION Einstufung	PRODUCT SPECIFICATION Produktspezifikation	No. DS-1x55-2400-102	REV. 1.10
SUBJECT Thema	CLASS 2 BLUETOOTH MODULE Bluetooth Modul der Klasse 2	PAGE Seite	4 of 34
CUSTOMER'S CODE PAN1455/1555	PANASONIC'S CODE ENW89815CxKF/ENW89815AxKF	DATE Datum	27.06.2011

1. KEY FEATURES

Schlüsseleigenschaften

- Bluetooth specification v2.0 + EDR (**Enhanced Data Rate**)
- CSR BlueCore6-ROM inside
- Complete Co-location and Co-existence with IEEE 802.11 (AWMA, AFH and SFH)
- Fast Connection Setup
- Extended SCO Link
- RF output power class 2 with power control
- Supply Voltage 3.0V to 3.6V
- Internal crystal oscillator (26MHz, 14.7456 MHz and 32 kHz for deep sleep)
- Surface mount type
 - PAN1455: 13.5 x 18.75 x 2.85 mm
 - PAN1555: 13.5 x 22.75 x 2.85 mm
- Built-in shielding to be compliant to FCC
- Full Bluetooth data rate up to 2178kbps asymmetric
- Support for all Bluetooth power saving modes (Park, Sniff, Hold)
- Support for very low-power modes (deep sleep and power down)
- Optional support for ultra-low-power mode. Standby with Battery-Backup
- PCM Interface Master / Slave supporting 13 or 16 bit linear, 8 bit μ -law or A-law Codecs and CVSD transcoders on up to 3 SCO channels
- Full 8- to 128-bit encryption
- High sensitivity design (-86 dBm typ.)
- 3 UART, USB, I2C and SPI Interface
- 18 GPIO's for individual usage for your embedded software
- 3 Channel ADC and 1 Channel DAC
- Cortex-M3 ST32F103 core for embedded profiles or application software
- Manufactured in conformance with RoHS

2. APPLICATIONS FOR THE MODULE

Applikationen für das Modul

All Embedded Wireless Applications

- | | |
|--|---|
| <ul style="list-style-type: none"> • Access Points • Printer Adapters | <ul style="list-style-type: none"> • Cable Replacement • Personal Digital Assistants (PDAs) |
| <ul style="list-style-type: none"> • Printers • Scanners • Wireless Sensors | <ul style="list-style-type: none"> • Access Points • Computers and Peripherals • Industrial Control Applications |

CLASSIFICATION Einstufung	PRODUCT SPECIFICATION Produktspezifikation	No. DS-1x55-2400-102	REV. 1.10
SUBJECT Thema	CLASS 2 BLUETOOTH MODULE Bluetooth Modul der Klasse 2	PAGE Seite	5 of 34
CUSTOMER'S CODE PAN1455/1555	PANASONIC'S CODE ENW89815CxKF/ENW89815AxKF	DATE Datum	27.06.2011

3. DESCRIPTION FOR THE MODULE Modulbeschreibung

PAN1455/1555 is a short-range class 2 module for implementing Bluetooth functionality into various electronic devices. The module consists of three major parts; a baseband controller, a EEPROM memory and a radio that operates in the license-free 2.45 GHz ISM band.

The module is listed as a Bluetooth End Product (EPL). Customers have to list their product under the BT QDID: B015522

Communication between the module and the host controller is carried out normally via UART. Optional via below interfaces. Please contact your local sales office for further details on additional options.

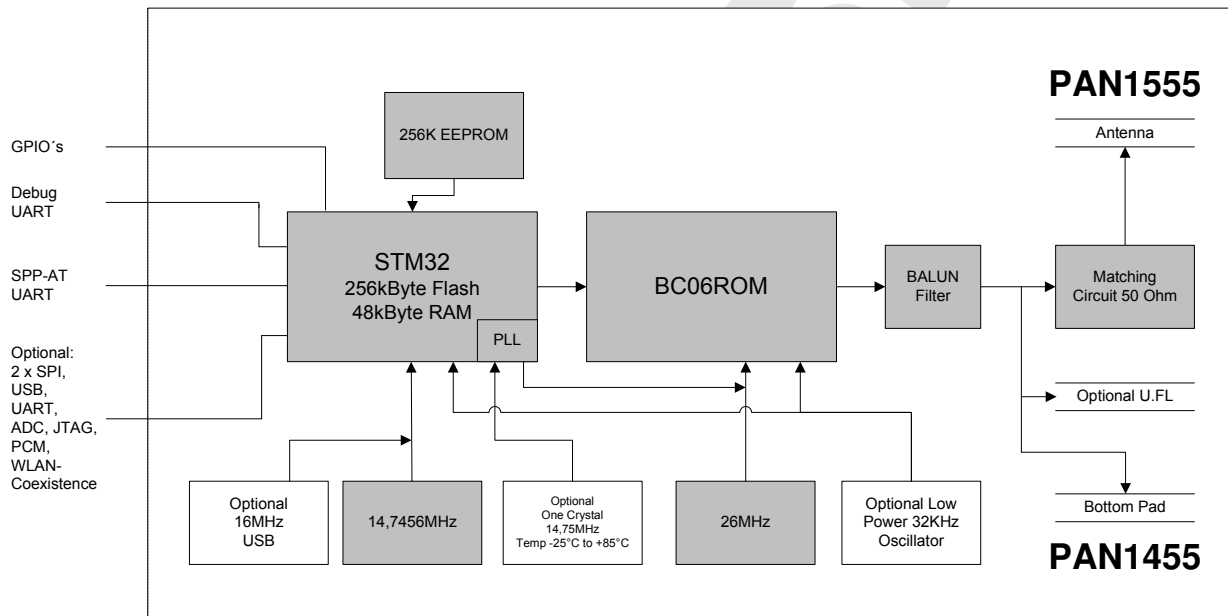

Figure 3.1 PAN1455/1555 Block-Diagram

CLASSIFICATION Einstufung	PRODUCT SPECIFICATION Produktspezifikation	No. DS-1x55-2400-102	REV. 1.10
SUBJECT Thema	CLASS 2 BLUETOOTH MODULE Bluetooth Modul der Klasse 2	PAGE Seite	6 of 34
CUSTOMER'S CODE PAN1455/1555	PANASONIC'S CODE ENW89815CxKF/ENW89815AxKF	DATE Datum	27.06.2011

4. SCOPE OF THIS DOCUMENT Umfang dieses Dokumentes

This product specification applies to the class 2 bluetooth module ENW89815CxKF/ENW89815AxKF. The different characters indicates different versions (refer to chapter 24 Ordering Information) The used bluetooth chip is the BlueCore6 from the company CSR. (www.csr.com).

Diese Produktionsunterlagen beziehen sich auf das Class 2 Bluetooth Modul ENW89815CxKF/ENW89815AxKF.

Die unterschiedlichen Zeichen bezeichnen verschiedene Versionen (Erklärung im Kapitel 24 Ordering Information)

Der verwendete Bluetooth Chip ist der BlueCore6 der Firma CSR.

5. HISTORY FOR THIS DOCUMENT Versionsverwaltung dieses Dokumentes

Revision Version	Date Datum	Modification / Remarks Änderungen / Bemerkungen
0.90	06.03.2009	Preliminary release.
0.91	30.03.2009	Add FCC Notice
0.92	04.05.2009	Include RF-Performance and current consumption
0.93	06.05.2009	Do minor changes in formatting, content links now included.
0.94	29.05.2009	Include final tables and Interface description
0.95	28.08.2009	SW-Status updated
1.00	01.02.2011	Power update for min values, add foot note from CSR, add CSR datasheet in appendix, add HDP Partnumbers, add link to Stollmann SW support page. Include BT Listing QDID information.
1.10	27.06.2011	Updated laser label information in chapter 20 Labelling Drawing.

CLASSIFICATION Einstufung	PRODUCT SPECIFICATION Produktspezifikation	No. DS-1x55-2400-102	REV. 1.10
SUBJECT Thema	CLASS 2 BLUETOOTH MODULE Bluetooth Modul der Klasse 2	PAGE Seite	7 of 34
CUSTOMER'S CODE PAN1455/1555	PANASONIC'S CODE ENW89815CxKF/ENW89815AxKF	DATE Datum	27.06.2011

6. TERMINAL LAYOUT
Anschlußbelegung

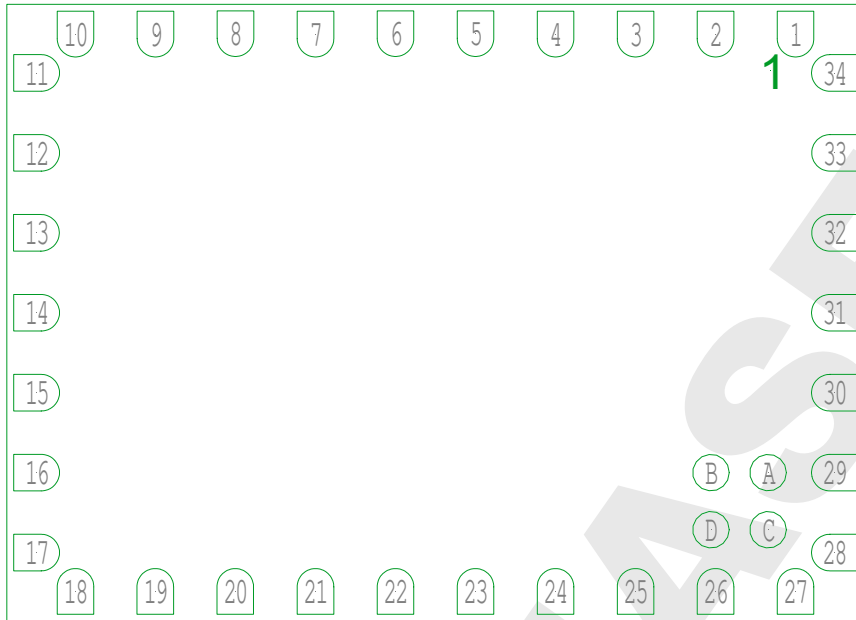

Figure 6.1 PAN1455/1555 Pin Numbering Bottom View

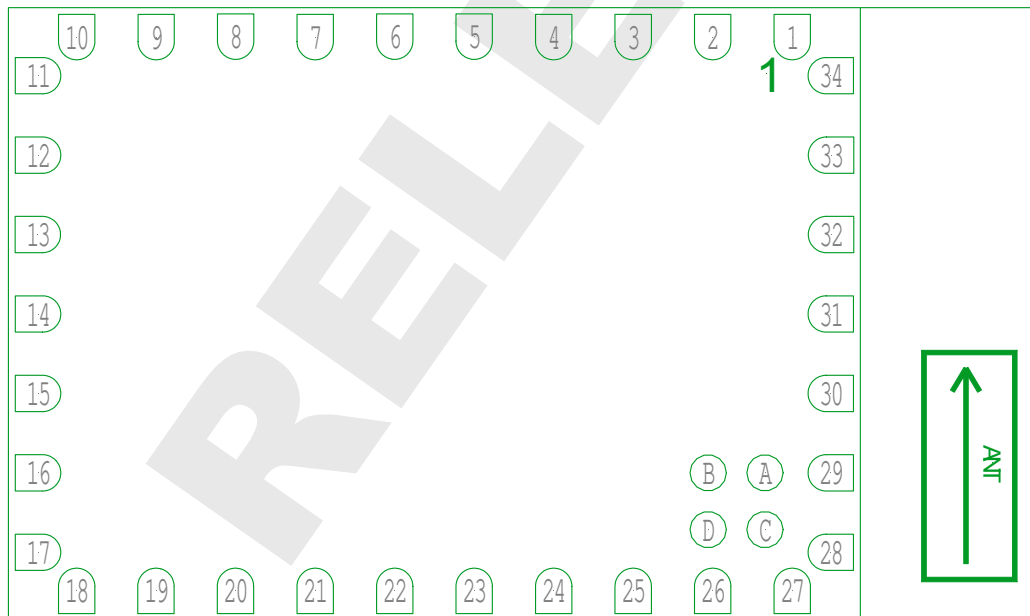

Figure 6.2 PAN1455/1555 Pin Numbering Bottom View

CLASSIFICATION Einstufung	PRODUCT SPECIFICATION Produktspezifikation	No. DS-1x55-2400-102	REV. 1.10
SUBJECT Thema	CLASS 2 BLUETOOTH MODULE Bluetooth Modul der Klasse 2	PAGE Seite	8 of 34
CUSTOMER'S CODE PAN1455/1555	PANASONIC'S CODE ENW89815CxKF/ENW89815AxKF	DATE Datum	27.06.2011

6.1. GENERAL PIN ASSIGNMENT

No	Pin Name	Type	PU/PD	Active	Description
1	GND1	P	-	-	Connect to Ground
2	ANT	I/O	-	-	Antenna Connector
3	UART_RTS#	I	PD	H	UART Request To Send (active low)
4	UART_TXD	I	PD	L	UART Data Input, weak internal Pull-Down
5	UART_RXD	O	-	L	UART Data Output
6	UART_CTS#	O	-	H	UART Clear To Send, internal Pull-Up
7	GPIO[9]/PCM_CLK	I/O	PU	L	General Purpose Input/Output, weak internal Pull-Up / PCM Data Clock Output
8	GPIO[10]/PCM_O/TXD3	I/O	PU	L	General Purpose Input/Output, weak internal Pull-Up / PCM Data Output/ UART3 DATA Output
9	GPIO[7]/PCM_SYNC	I/O	PD	H	General Purpose Input/Output, weak internal Pull-Down / PCM Data Sync Output
10	GND2	P	-	-	Connect to Ground
11	ATRST/SPI2_MISO	I/O	PU	H	JTAG reset, internal Pull-Up / SPI2 Master In - Slave Out
12	GPIO[8]/PCM_I/RXD3	I/O	PU	L	General Purpose Input/Output, weak internal Pull-Up / PCM Data Input / UART3 DATA Input
13	ATDI/SPI2_CS	I/O	PU	-	JTAG test data input, weak internal Pull-Up / SPI2 Chip Select
14	ATMS	I	PU	-	JTAG mode select, weak internal Pull-Up
15	reserved	I	PD	-	for Debug-Use only, nc
16	VCC	P	-	-	VCC
17	RESET#	I	PU	L	Reset input
18	GND3	P	-	-	Connect to Ground
19	GPIO[14]	I/O	PU	L	General Purpose Input/Output, weak internal Pull-Up
20	GPIO[13]	I/O	PD	H	General Purpose Input/Output, weak internal Pull-Down
21	GPIO[15]	I/O	PU	L	General Purpose Input/Output, weak internal Pull-Up
22	GPIO[6]/ADC	I/O	PD	H	General Purpose Input/Output, weak internal Pull-Up / ADC Input
23	ATDO/SPI2_SCK	O	PU	-	JTAG test data output
24	ATCK	O	PD	-	JTAG clock, weak internal Pull-Down
25	GPIO[3]/SPI_CLK	I/O	PD	H	General Purpose Input/Output, weak internal Pull-Down / SPI Clock
26	GPIO[0]/SPI_MOSI	I/O	PD	H	General Purpose Input/Output, weak internal Pull-Down / SPI Master Out – Slave In
27	GND4	P	-	-	Connect to Ground
28	GPIO[2]/SPI_CS	I/O	PD	H	General Purpose Input/Output, weak internal Pull-Down / SPI Chip Select
29	GPIO[1]/SPI_MISO	I/O	PD	H	General Purpose Input/Output, weak internal Pull-Down / SPI Master In – Slave Out
30	GPIO[5]/TXD2	I/O	PD	H	General Purpose Input/Output, weak internal Pull-Down / UART2 DATA Output
31	GPIO[4]/RXD2	I/O	PD	H	General Purpose Input/Output, weak internal Pull-Down / UART2 DATA Input
32	USB_DM	I/O	PD	-	USB Data Minus Terminal
33	USB_DP	I/O	PD	-	USB Data Plus Terminal
34	GPIO[17]/TAMPER	I/O	PD	-	General Purpose Input/Output, weak internal Pull-Down, do not use as current source! / TAMPER In
A	GPIO[16]/SPI2_MOSI	I/O	PU	L	General Purpose Input/Output, weak internal Pull-Up / SPI2 Master Out – Slave In
B	GPIO[12]/I2C_SCL	I/O	PU	L	General Purpose Input/Output, weak internal Pull-Up / I2C Serial Clock Line
C	GPIO[11]/I2C_SDA	I/O	PU	L	General Purpose Input/Output, weak internal Pull-Up / I2C Serial Data Line
D	VBAT	P	-	-	Optional Batterie Backup

Type: PU - Pulled up; PD – pulled down; P – Power; I – Input; O – Output; I/O - bidirectional

CLASSIFICATION Einstufung	PRODUCT SPECIFICATION Produktspezifikation	No. DS-1x55-2400-102	REV. 1.10
SUBJECT Thema	CLASS 2 BLUETOOTH MODULE Bluetooth Modul der Klasse 2	PAGE Seite	9 of 34
CUSTOMER'S CODE PAN1455/1555	PANASONIC'S CODE ENW89815CxKF/ENW89815AxKF	DATE Datum	27.06.2011

6.2. APPLICATION SPECIFIC PIN DESCRIPTION

6.2.1. SPP configuration DCE Mode

No	Pin Name	SPP-Function	Type	PU/PD	Active	Description
1	GND1	Power	P	-	-	Connect to Ground
2	ANT	Antenna	I/O	-	-	Antenna Connector
3	UART_RTS#	/RTS	I	PU	L	UART Request To Send
4	UART_TXD	TXD	I	PD	H	UART Data Input
5	UART_RXD	RXD	O		H	UART Data Output
6	UART_CTS#	/CTS	O		L	UART Clear To Send
7	GPIO[9]/PCM_CLK	/LED2	O		L	Bluetooth connected. Active if a Bluetooth connection exists. Inactive in idle state. Flashes during startup.
8	GPIO[10]/PCM_O/TXD3	UA2	O			User Output 2
9	GPIO[7]/PCM_SYNC	/LED1	O		L	Device Ready
10	GND2	Power	-	-	-	Connect to Ground
11	ATRST/SPI2_MISO	reserved	I/O	PU	H	leave open
12	GPIO[8]/PCM_I/RXD3	/UE1	I	PU	L	User Input 1
13	ATDI/SPI2_CS	reserved	I/O	PU	-	leave open
14	ATMS	reserved	I	PU	-	leave open
15	BOOT0	reserved	I	PD	H	for Debug-Use only, nc
16	VCC	Power	-	-	-	VCC
17	RESET#	/RESET	I	PU	L	Reset input (active low for 5 ms); Schmitt triggered
18	GND3	Power	-	-	-	Connect to Ground
19	GPIO[14]	/RTC-OUT	O		L	DSR in DCE mode, DTR in DTE mode
20	GPIO[13]	/RTC-IN	I	PU	L	DTR in DCE mode, DSR in DTE mode
21	GPIO[15]	/DCD or /DCD-DTE	I/O	PU	L	Data Carrier Detect , Input in DTE mode Output in DCE mode
22	GPIO[6]/ADC	/RI	I/O	PU	L	Ring Indicator, Input in DTE mode Output in DCE mode
23	ATDO/SPI2_SCK	reserved	O	PU	-	JTAG
24	ATCK	reserved	O	PD	-	JTAG
25	GPIO[3]/SPI_CLK	reserved	I/O	PD	H	leave open
26	GPIO[0]/SPI_MOSI	reserved	I/O	PD	H	leave open
27	GND4	Power	-	-	-	Connect to Ground
28	GPIO[2]/SPI_CS	reserved	O			leave open
29	GPIO[1]/SPI_MISO	/UE2	I	PD	H	User Input 2, Break Detect (1)
30	GPIO[5]/TXD2	reserved	O			leave open
31	GPIO[4]/RXD2	DTE-/DCE Select	I	PD	H	DTE (high) DCE (low) mode selector
32	USB_DM	reserved	I/O	PD	-	leave open
33	USB_DP	reserved	I/O	PD	-	leave open
34	GPIO[17]/TAMPER	reserved	I/O	PD	-	leave open
A	GPIO[16]/SPI2_MOSI	reserved	I/O	PU	L	leave open
B	GPIO[12]/I2C_SCL	reserved	I/O	PU	L	leave open
C	GPIO[11]/I2C_SDA	reserved	I/O	PU	L	leave open
D	VBAT	Power	-	-	-	Optional Batterie Backup

Type: PU - Pulled up; PD – pulled down; P – Power; I – Input; O – Output; I/O - bidirectional

All other pins do not have a dedicated functionality in SPP mode. See 6.1 General Pin Assignment for all other terminals.

CLASSIFICATION Einstufung	PRODUCT SPECIFICATION Produktspezifikation	No. DS-1x55-2400-102	REV. 1.10
SUBJECT Thema	CLASS 2 BLUETOOTH MODULE Bluetooth Modul der Klasse 2	PAGE Seite	10 of 34
CUSTOMER'S CODE PAN1455/1555	PANASONIC'S CODE ENW89815CxKF/ENW89815AxKF	DATE Datum	27.06.2011

7. TERMINAL SPECIFICS Interfacebeschreibungen

7.1. RF-INTERFACE - ANT

The PAN1455 presents a 50Ω impedance on the antenna pin. If you need antenna support please e-mail to wireless@ecom.panasonic.de or use the PAN1555 with integrated ceramic antenna.

7.2. POWER SUPPLY

PAN1455/1555 require a power supply with the following characteristics:

Typical : 3.3VDC, min.: 3.0VDC – max.: 3.6VDC, low noise ($\leq 10\text{mV}$), $>80\text{mA}$ peak

Due to the technological requirements and the pulsed radio transmission the supply needs to be fed by an ultra fast (response time $\leq 20\mu\text{s}$) linear regulator placed as close as possible to the VSUP pin (16). Functionality has been verified with the following types: TOREX: XC6204x332xx or XC6401xx42xx

It is also recommended to place a low ESR capacitor with at least $10\mu\text{F}$ as close as possible to the VSUP pin (16).

NOTE: You must ensure that during operation the supply voltage never drops below 2.8 VDC. Otherwise the flash contents (firmware and/or configuration data) can get lost.

7.3. POWER-ON-RESET

PAN1455/1555 are equipped with circuitry for generating Power ON/-OFF Reset from the internal core voltage. A reset is generated when the core voltage falls below typically 1.88V and is released when it rises above typically 1.92V.

In case of Power-On, Power-Off, Watchdog, Low-Power or Software, RESET# acts as an Output by holding RESET# at $\leq 0.3\text{V}$ for min. 1,5ms and max. 3,5ms.

In an application with an external Reset as an Input, for example external Reset-Controller, we recommend to use Open-Drain-Output for this circuit. An external reset shall be generated at RESET# $\leq 0.3\text{V}$ for $\geq 5\text{ms}$ after VSUP has stabilized in the recommended voltage range.

The following table shows the pin states of PAN1455/1555 on reset.

Pin Name	State: PAN1455/1555
UART_RTS#	Input Floating
UART_TXD	Input Floating
UART_RXD	Input Floating
UART_CTS#	Input Pull-Up
GPIO[0] – GPIO[13], GPIO[16], GPIO[17]	Input Floating
GPIO[14]	Input Pull-Up
GPIO[15]	Input Pull-Up
Boot0	Input Pull-Down
ATRST	Input Pull-Up
ATDI	Input Pull-Up
ATMS	Input Pull-Up
ATDO	Input Floating
ATCK	Input Pull-Down
USB_DM	Input Floating
USB_DP	Input Floating

CLASSIFICATION Einstufung	PRODUCT SPECIFICATION Produktspezifikation	No. DS-1x55-2400-102	REV. 1.10
SUBJECT Thema	CLASS 2 BLUETOOTH MODULE Bluetooth Modul der Klasse 2	PAGE Seite	11 of 34
CUSTOMER'S CODE PAN1455/1555	PANASONIC'S CODE ENW89815CxKF/ENW89815AxKF	DATE Datum	27.06.2011

7.4. UART INTERFACE – TXD, RXD, CTS, RTS

The functionality of the interface corresponds to the V.24 / RS-232 standard on TTL-level.

Transmission speeds:

- 1200 bps
- 2400 bps
- 4800 bps
- 9600 bps
- 19200 bps
- 38400 bps
- 57600 bps
- 115200 bps
- 230400 bps
- 460800 bps
- 921200 bps

Character representation:

- 8 or 9 Bit, even/odd/no Parity, 1 or 2 stop bits
- 7 Bit, even/odd Parity, 1 or 2 stop bits
- 7 Bit no Parity, 2 or 3 stop bits

Hardware flow-control with UART_RTS and UART_CTS (active low)

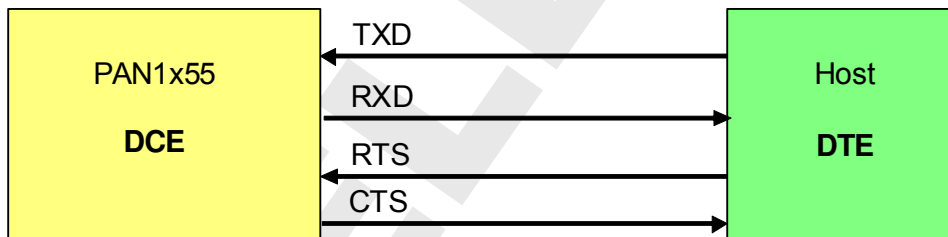

Figure 7.1 UART Signal Connections

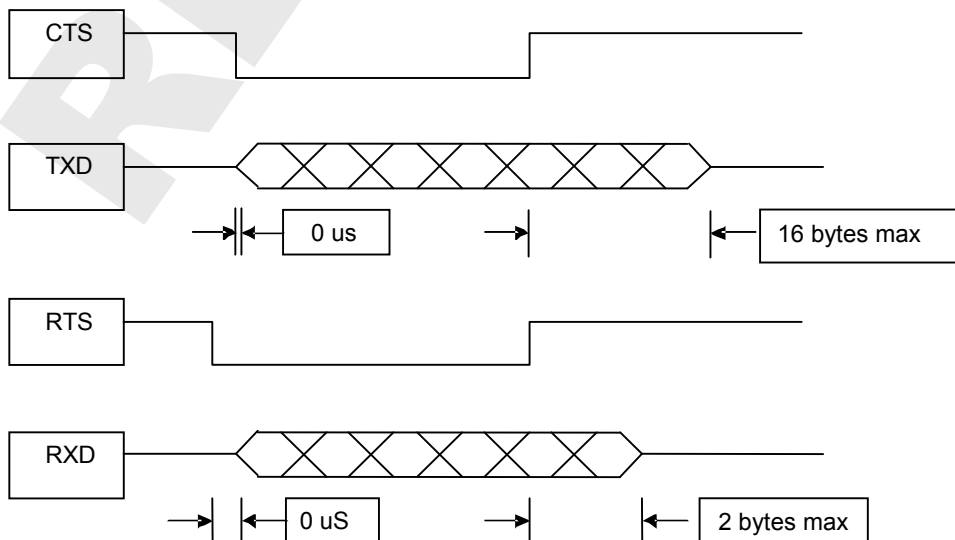

Figure 7.2 UART Timing Diagram

CLASSIFICATION Einstufung	PRODUCT SPECIFICATION Produktspezifikation	No. DS-1x55-2400-102	REV. 1.10
SUBJECT Thema	CLASS 2 BLUETOOTH MODULE Bluetooth Modul der Klasse 2	PAGE Seite	12 of 34
CUSTOMER'S CODE PAN1455/1555	PANASONIC'S CODE ENW89815CxKF/ENW89815AxKF	DATE Datum	27.06.2011

7.5. 3-WIRE SERIAL INTERFACE

When using only GND and UART_Rx, UART_Tx serial lines, you may leave UART_RTS# and UART_CTS# open.

Note: Not using flow control can result in loss of data.

7.6. USB INTERFACE^{1,2}

7.6.1. USB_DP, USB_DN

PAN1455/1555 contain a full speed USB version 2.0 compliant interface capable of directly driving an USB cable. The PAN1455/1555 operates as a USB peripheral and responds to requests from a USB master host controller.

7.7. GPIO INTERFACE

It is possible to use the programmable digital I/Os GPIO[0:17]. The Current from GPIO[17] is limited to 3mA max.

For 5V tolerant GPIO's refer to chapter 6.2.1SPP configuration DCE Mode

7.8. ADC³

It is possible to use the programmable I/Os PIO[0:3,6,7,13:15] as ADC.

The 12-bit ADC is a successive approximation analogue-to-digital converter. A/D conversion can be performed in single, continuous, scan or discontinuous mode.

7.9. DAC⁴

It is possible to use the programmable I/Os PIO[2,3] as ADAC

The DAC module is a 12-bit, voltage output digital-to-analogue converter. The DAC can be configured in 8- or 12-bit mode and may be used in conjunction with the DMA controller.

7.10. PCM INTERFACE⁵

PCM or Pulse Code Modulation is a sampling technique for digitising analogue signals.

The PCM interface for voice applications is provided via the PCM_OUT, PCM_IN, PCM_CLK and PCM_SYNC pins.

The PCM interface can act as master or as slave device.

In master mode, clock frequencies of 128kHz, 256kHz or 512kHz can be generated, when using the internal 4MHz clock. In slave mode, clock frequencies up to 2048kHz are accepted.

The Frame Clock is 8kHz. Long and Short Frame Sync are supported.

PAN1455/1555 interface directly to PCM audio devices including the following:

¹ subject to firmware support, contact Stollmann for current status.

² subject to hardware support, contact Stollmann for availability of variants

³ subject to firmware support, contact Stollmann for current status

⁴ subject to firmware support, contact Stollmann for current status

⁵ subject to firmware support, contact Stollmann for current status

CLASSIFICATION Einstufung	PRODUCT SPECIFICATION Produktspezifikation	No. DS-1x55-2400-102	REV. 1.10
SUBJECT Thema	CLASS 2 BLUETOOTH MODULE Bluetooth Modul der Klasse 2	PAGE Seite	13 of 34
CUSTOMER'S CODE PAN1455/1555	PANASONIC'S CODE ENW89815CxKF/ENW89815AxKF	DATE Datum	27.06.2011

- Qualcomm MSM3000 series and MSM5000 series CDMA base band devices
- OKI MSM7705 four channel A-law and μ -law codec
- WINBOND W681310 8-bit A-law and μ -law codec
- WINBOND W681360 13-bit linear codec
- STW 5093 5094 14-bit linear codec

8. KEY PARTS LIST

Liste der Schlüsselkomponenten

Part Name Teilenummer	Material Material
P.W.Board	Glass cloth epoxide resin with gold plating
BT-IC part name	BC63B239A04Q (Cambridge Silicon Radio Ltd www.csr.com) You have to register, before you can download the data sheet.
μ -Controller	ST32F103xxxx (Cortex baseed STMicroelectronics www.stm.com)

CLASSIFICATION Einstufung	PRODUCT SPECIFICATION Produktspezifikation	No. DS-1x55-2400-102	REV. 1.10
SUBJECT Thema	CLASS 2 BLUETOOTH MODULE Bluetooth Modul der Klasse 2	PAGE Seite	14 of 34
CUSTOMER'S CODE PAN1455/1555	PANASONIC'S CODE ENW89815CxKF/ENW89815AxKF	DATE Datum	27.06.2011

9. TEST CONDITIONS

Meßbedingungen

Measurements shall be made under room temperature and humidity unless otherwise specified.
Messungen unter normalen Bedingungen, Abweichungen sind gesondert notiert.

Temperature	25 ± 10°C	Humidity	40 to 85%RH
Temperatur	25 ± 10°C	Luftfeuchtigkeit	40 to 85%RH

10. ABSOLUTE MAXIMUM RATINGS ⁽¹⁾

Absolute Grenzwerte

The maximum ratings may not be exceeded under any circumstances, not even momentarily and individually, as permanent damage to the module will result.

No.	Item Punkt	Symbol Zeichen	Absolute Maximum Ratings Absolute Grenzwerte	Unit Einheit
1	Supply voltage Versorgungsspannung	V _{cc}	-0.4 to +3.7	V
2	Voltage on any pin Spannung an jedem Pin	V _{Pin}	GND -0.3 to V _{cc} +0.40	V
3	Storage temperature range Lagertemperatur	T _{stg}	-40 to +105	°C
4	Operating temperature range Betriebstemperatur	T _{op}	-40 to +85	°C
6	Lead temperature Löttemperatur	T _{Death}	See chapter 17.2	°C
7	ESD on any pin ESD Festigkeit	V _{ESD}	max 2000 V (C _{Load} =150pF, R _{Load} =330Ω)	V

Notes:

- (1) ABSOLUTE MAXIMUM RATINGS indicate limits beyond which damage to the device may occur.

11. ELECTRICAL REQUIREMENTS

V_{cc} = 3.3V, T_{amb} = 25°C if nothing else stated

No Nr.	Item Punkt	Condition Bedingung	Limit / Grenzen			Unit Einheit
			Min	Typ	Max	
1	Frequency Range Frequenzbereich		2400		2483.5	MHz
2	Load impedance Ausgangsimpedanz	Measured with network analyzer in the frequency range at antenna pin		50		Ω
3	Output return loss Ausgangs Anpassung	Receive Mode to 50Ω load Transmit Mode to 50Ω load	-10 -10			dBm
4	Supply voltage Versorgungsspg.	The typical voltage is recommended V _{cc} at voltage pin	3.0	3.3	3.6	Vdc
5	Ripple on V _{cc} AC Anteil auf V _{cc}	Ripple frequency ≥200kHz Ripple frequency <200kHz			10	mVms

CLASSIFICATION Einstufung	PRODUCT SPECIFICATION Produktspezifikation	No. DS-1x55-2400-102	REV. 1.10
SUBJECT Thema	CLASS 2 BLUETOOTH MODULE Bluetooth Modul der Klasse 2	PAGE Seite	15 of 34
CUSTOMER'S CODE PAN1455/1555	PANASONIC'S CODE ENW89815CxKF/ENW89815AxKF	DATE Datum	27.06.2011

12. I/O OPERATING CHARACTERISTICS

V_{cc} = 3.3V, T_{amb} = 25°C if nothing else stated

Symbol	Item	Condition	Limit			Unit
			Min	Typ	Max	
V _{IL}	Low-Level Input Voltage	VSUP = 3.3V	- 0.5	-	0.8	V
V _{IH}	High-Level Input Voltage		2.0	-	VSUP +0.5	V
V _{OL}	Low-Level Output Voltage	I _{OL} = mA	-	-	0.2	V
V _{OH}	High-Level Output Voltage	I _{OH} = -4mA	VSUP-0.2	-	-	V
I _{OL}	Low -Level Output Current (except GPIO[17])	V _{OL} = 0.4V	-	-	8	mA
I _{OH}	High-Level Output Current (except GPIO[17])	V _{OH} = 2.4V	-	-	8	mA
I _{OL} (GPIO[17])	Low -Level Output Current at GPIO[17]	V _{OL} = 0.4V	-	-	3	mA
I _{OH} (GPIO[17])	High-Level Output Current at GPIO[17]	V _{OH} = 2.4V	-	-	3	mA
I _{wp-u}	Input-current	Weak pull-up typ. 40kΩ	-5.0	-1.0	-0.2	μA
I _{wp-d}	Input-current	Weak pull-down typ. 40kΩ	+0,2	+1.0	+5.0	μA
I _{lc}	I/O pad leakage current	Standard I/Os	-1.0	0	+1.0	μA
I _{lc}	I/O pad leakage current	V _{in} = 5V	-3,0	0	+3,0	μA
C _i	Input Capacitance		-	5	-	pF

13. USB INTERFACE

V_{cc} = 3.3V, T_{amb} = 25°C if nothing else stated

Item	Limit		Unit
	Min	Max	
Input logic level low	-	0.3xVSUP	V
Input logic level high	0.7xVSUP	5.5	V
Output logic level low)*	0	0.2	V
Output logic level high)*	2.8	VSUP	V

)* connected to correctly terminated USB cable

CLASSIFICATION Einstufung	PRODUCT SPECIFICATION Produktspezifikation	No. DS-1x55-2400-102	REV. 1.10
SUBJECT Thema	CLASS 2 BLUETOOTH MODULE Bluetooth Modul der Klasse 2	PAGE Seite	16 of 34
CUSTOMER'S CODE PAN1455/1555	PANASONIC'S CODE ENW89815CxKF/ENW89815AxKF	DATE Datum	27.06.2011

14. TYPICAL CURRENT CONSUMPTION

14.1. SPP CONFIGURATION

14.1.1. Deep Sleep State

The Bluetooth RF is completely deactivated, no paging requests from other Bluetooth devices will be recognized. Only rising control line DTR will activate the PAN1455/1555 and may initiate a Bluetooth link dependent on other parameters.

Note: In Deep Sleep state the AT command set is not active, CTS line is low.

14.1.2. Power Down State

The Bluetooth RF is activated every 1.25 seconds, paging requests from other Bluetooth devices will be recognized after that intervals and accepted if allowed. Additionally rising control line DTR will activate the PAN1455/1555 and may initiate a Bluetooth link dependent on other parameters.

Note: In Power down state the AT command set is not active, CTS line is low.

14.1.3. Idle State

No power down mode activated.

All functionality is available immediately including connection control using AT command set.

14.2. POWER CONSUMPTION

The following values are approximate power consumption values in the different states:

VSUP = 3.3V, T_{amb} = 25°C

Condition	Current Consumption		Unit
	I _{MEAN}	I _{PEAK}	
Idle, no page scan, no inquiry scan, Uart baud rate: 1200 baud	7,5	15	mA
Idle, all functions available, no Bluetooth link, page scan & inquiry scan interval 1,28s	8	56	mA
Idle, all functions available, no Bluetooth link, continuous page scans	50	60	mA
Bluetooth connected, no data traffic – close range (Slave)	10	56	mA
Bluetooth connected, data traffic 115 kbit/s – close range (Slave)	33	61	mA
ACL connected DH5 max PWR, shortest Poll Period (Slave)	43	68	mA
ACL connected DH5 min PWR, shortest Poll Period (Slave)	42	67	mA
ACL connected DH1 max PWR, shortest Poll Period (Slave)	43	69	mA
ACL connected DH1 min PWR, shortest Poll Period (Slave)	41	67	mA
Power Down	7,5	--	mA
Device in reset	1,5	--	mA

CLASSIFICATION Einstufung	PRODUCT SPECIFICATION Produktspezifikation	No. DS-1x55-2400-102	REV. 1.10
SUBJECT Thema	CLASS 2 BLUETOOTH MODULE Bluetooth Modul der Klasse 2	PAGE Seite	17 of 34
CUSTOMER'S CODE PAN1455/1555	PANASONIC'S CODE ENW89815CxKF/ENW89815AxKF	DATE Datum	27.06.2011

14.3. POWER-UP TIME

The time until the PAN1455/1555 is able to accept link requests or serial data depends on the firmware version and the software parameters RSTTIM and RSTMSG. In the SPP firmware version 1.001 the module is command ready after at least 0,3s (RSTTIM=3 / RSTMSG=0) and 2,16s (RSTTIM=40 / RSTMSG=1) maximum. Bluetooth links are accepted 2,3s after reset.

15. ELECTRICAL RF-CHARACTERISTICS

Vcc = 3.0V to 3.6V, Tamb = - 40°C to +85°C

Receiver	Frequency [GHz]	Limit			BT Spec	Unit
		Min	Typ	Max		
Sensitivity at 0.1% BER DH1	2.402	-70,0	-85,3		≤-70	dBm
	2.441	-70,0	-85,4			
	2.480	-70,0	-86,0			
Sensitivity at 0.1% BER DH5	2.402	-70,0	-84,4		≤-70	dBm
	2.441	-70,0	-84,9			
	2.480	-70,0	-85,6			
Sensitivity at 0.1% BER EDR2, PI/4 DQPSK	2.402	-70,0	-88,1		≤-70	dBm
	2.441	-70,0	-88,3			
	2.480	-70,0	-88,1			
Sensitivity at 0.1% BER EDR3, 8DPSK ^{c)}	2.402	-70,0	-82,0		≤-70	dBm
	2.441	-70,0	-82,7			
	2.480	-70,0	-82,4			
Maximum received signal at 0.1% BER with DH1		-20,0	>10		≥-20	dBm
Maximum received signal at 0.1% BER with DH5		-20,0	>10		≥-20	dBm
Maximum received signal at 0.1% BER with EDR2, PI/4 DQPSK		-20,0	>0		≥-20	dBm
Maximum received signal at 0.1% BER with EDR3, 8DPSK		-20,0	>0		≥-20	dBm
C/I co-channel ^{a)}			6	11	≤ 11	dB
Adjacent channel selectivity C/I f = f ₀ + 1MHz ^{a)}			-5	0	≤ 0	dB
Adjacent channel selectivity C/I f = f ₀ - 1MHz ^{a)}			-5	0	≤ 0	dB
Adjacent channel selectivity C/I f ≥ f ₀ + 2MHz ^{a)}			-38	-30	≤ -30	dB
Adjacent channel selectivity C/I f ≤ f ₀ - 2MHz ^{a)}			-22	-20	≤ -20	dB
Adjacent channel selectivity C/I f ≥ f ₀ + 3MHz ^{a)}			-42	-40	≤ -40	dB
Adjacent channel selectivity C/I f ≤ f ₀ - 5MHz ^{a)}			-45	-40	≤ -40	dB
Adjacent channel selectivity C/I f = f _{image} ^{a)}			-15	-9	≤ -9	dB

Notes: a) For BER less then 0,1%. Applies according to BT Test Specification Ver. 1.2/2.0/2.0 + EDR only for Tamb = 20°C

CLASSIFICATION Einstufung	PRODUCT SPECIFICATION Produktspezifikation	No. DS-1x55-2400-102	REV. 1.10
SUBJECT Thema	CLASS 2 BLUETOOTH MODULE Bluetooth Modul der Klasse 2	PAGE Seite	18 of 34
CUSTOMER'S CODE PAN1455/1555	PANASONIC'S CODE ENW89815CxKF/ENW89815AxKF	DATE Datum	27.06.2011

Vcc = 3.3V, Tamb = +25°C

Transmitter	Frequency [GHz]	Limit			BT Spec	Unit
		Min	Typ	Max		
RF transmit power 50 Ω load with GFSK Modulation and default settings ^{b)}	2.402	2,0	3,9			dBm
	2.441	2,0	3,2			
	2.480	2,0	3,0			
RF transmit power 50 Ω load with EDR, PI/4 DQPSK Modulation and default settings ^{b)}	2.402 GFSK		2,7			dBm
	2.402 DPSK		1,6			
	2.441 GFSK		2,7			
	2.441 DPSK		1,6			
	2.480 GFSK		2,2			
	2.480 DPSK		1,0			
RF transmit power 50 Ω load with EDR, 8DPSK Modulation and default settings ^{b)}	2.402 GFSK		2,6			dBm
	2.402 DPSK		1,6			
	2.441 GFSK		2,7			
	2.441 DPSK		1,6			
	2.480 GFSK		2,2			
	2.480 DPSK		1,0			
RF power control range		-21	-	4,0		dB
RF power range control resolution		3,2	3,9	4,6	2 to 8	dB
20 dB bandwidth for modulated carrier		920	924	1000	≤1000	kHz
Initial carrier frequency tolerance		-75	-10	75	≤ ±75	kHz
Carrier frequency drift (packet DH1)		-25	11	25	≤ ±25	kHz
Drift Rate		-20	0	20	20	kHz/ 50μs
Δf _{1avg} "Maximum Modulation"		140	166	175	≥140 to ≤175	kHz
Δf _{2avg} "Minimum Modulation"		115	155	-	≥ 115	kHz

Notes: b) excluding antenna gain

16. MECHANICAL REQUIREMENTS

Mechanische Anforderungen

No.	Item Punkt	Limit Grenzwerte	Condition Bedingung
1	Solderability Lötbarkeit	More than 75% of the soldering area shall be coated by solder Mehr als 75% der Lötfläche soll mit Lötpaste bedeckt sein.	Reflow soldering with recommendable temperature profile
2	Resistance to soldering heat	It shall be satisfied electrical requirements and not be mechanical damage	See chapter 17.2

CLASSIFICATION Einstufung	PRODUCT SPECIFICATION Produktspezifikation	No. DS-1x55-2400-102	REV. 1.10
SUBJECT Thema	CLASS 2 BLUETOOTH MODULE Bluetooth Modul der Klasse 2	PAGE Seite	19 of 34
CUSTOMER'S CODE PAN1455/1555	PANASONIC'S CODE ENW89815CxKF/ENW89815AxKF	DATE Datum	27.06.2011

17. SOLDERING TEMPERATURE-TIME PROFILE (FOR REFLOW SOLDERING)

Temperatur-Zeit Profil für die Reflowlötung

17.1. FOR LEAD SOLDER

Recommended temp. profile for reflow soldering

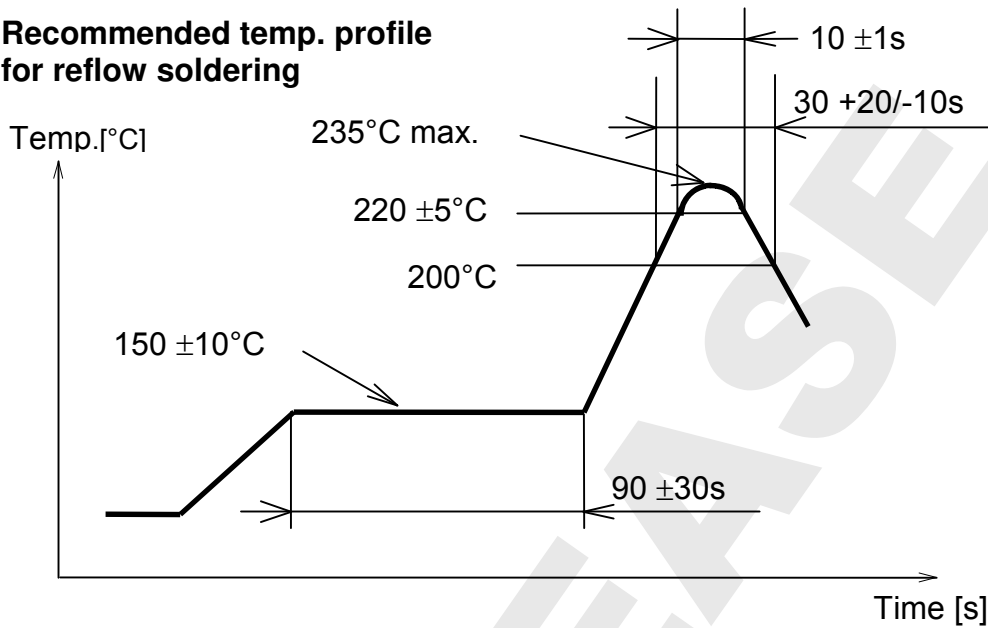

17.2. FOR LEADFREE SOLDER

Our used temp. profile for reflow soldering

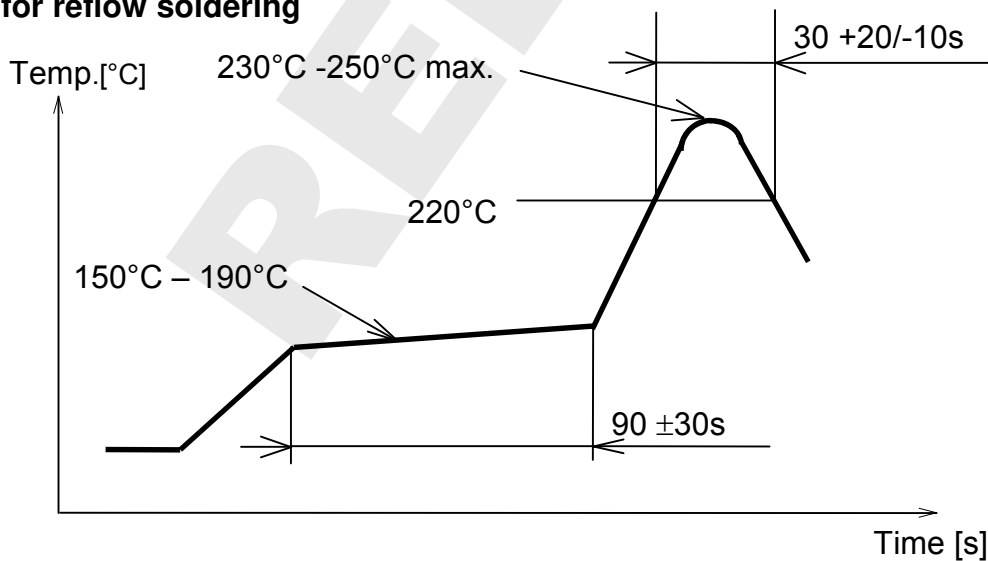

Reflow permissible cycle: 2
Opposite side reflow is prohibited due to module weight.

CLASSIFICATION Einstufung	PRODUCT SPECIFICATION Produktspezifikation	No. DS-1x55-2400-102	REV. 1.10
SUBJECT Thema	CLASS 2 BLUETOOTH MODULE Bluetooth Modul der Klasse 2	PAGE Seite	20 of 34
CUSTOMER'S CODE PAN1455/1555	PANASONIC'S CODE ENW89815CxKF/ENW89815AxKF	DATE Datum	27.06.2011

18. MODULE DIMENSION
Modulabmessungen

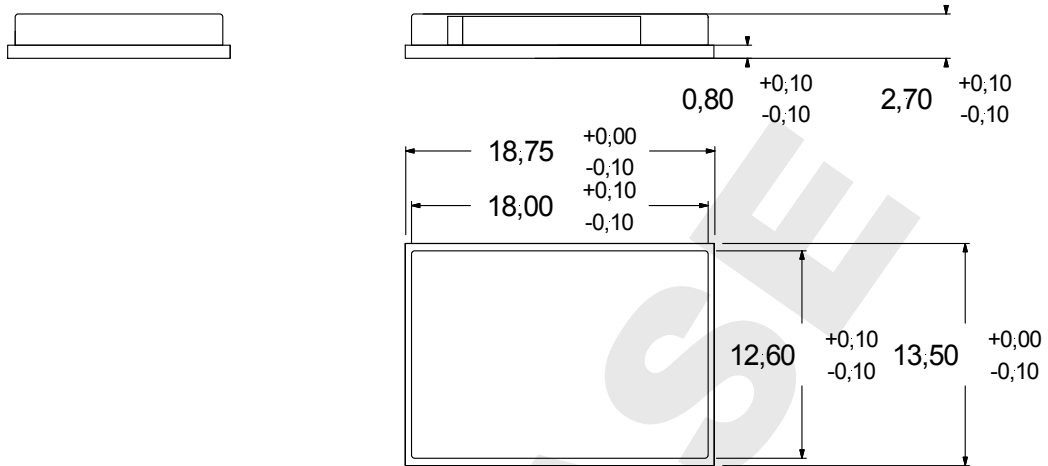

Figure 18.1 PAN1455 dimensions

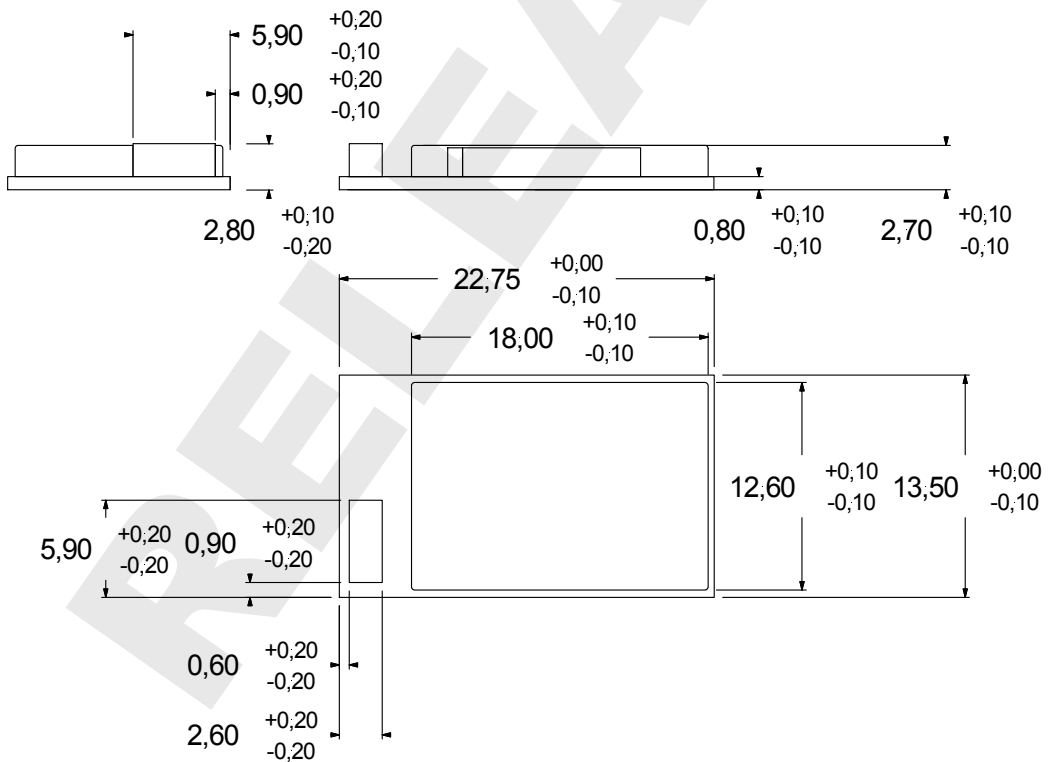

Figure 18.2 PAN1555 dimensions

CLASSIFICATION Einstufung	PRODUCT SPECIFICATION Produktspezifikation	No. DS-1x55-2400-102	REV. 1.10
SUBJECT Thema	CLASS 2 BLUETOOTH MODULE Bluetooth Modul der Klasse 2	PAGE Seite	21 of 34
CUSTOMER'S CODE PAN1455/1555	PANASONIC'S CODE ENW89815CxKF/ENW89815AxKF	DATE Datum	27.06.2011

19. RECOMMENDED FOOT PATTERN
Empfohlenes Land Pattern

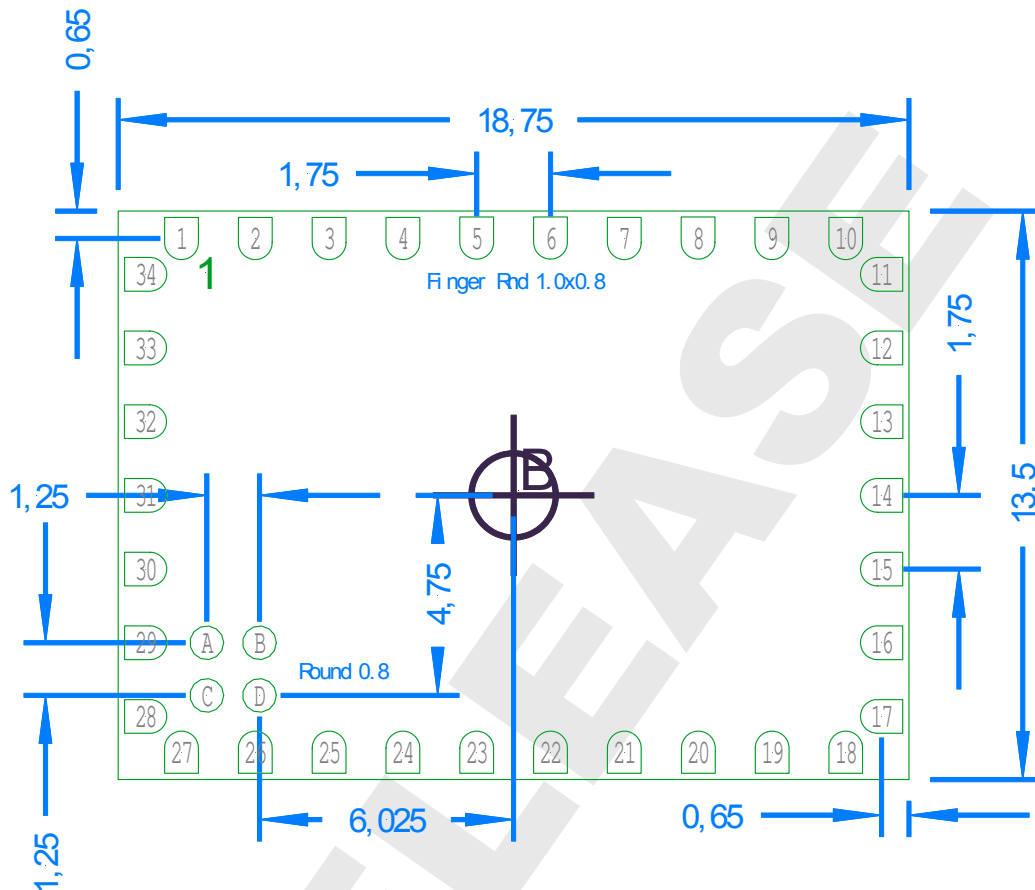
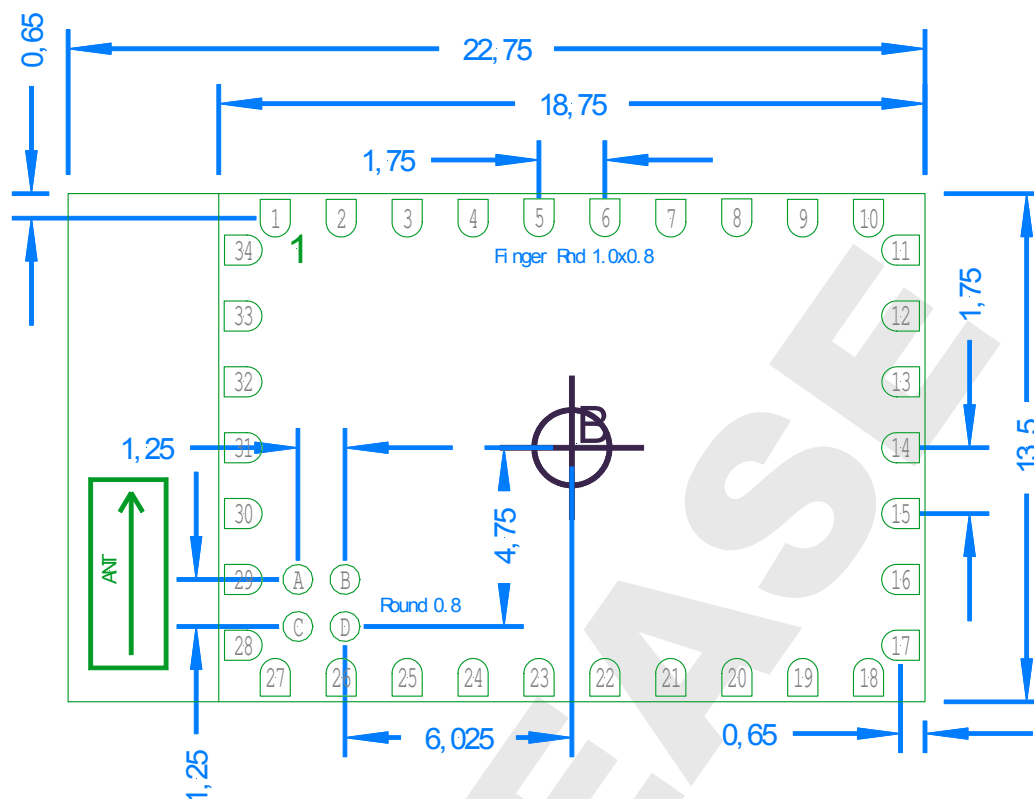

Figure 19.1 PAN1455 Recommended Land pattern
(Top-View not scaled)

Dimensions in mm.

CLASSIFICATION Einstufung	PRODUCT SPECIFICATION Produktspezifikation	No. DS-1x55-2400-102	REV. 1.10
SUBJECT Thema	CLASS 2 BLUETOOTH MODULE Bluetooth Modul der Klasse 2	PAGE Seite	22 of 34
CUSTOMER'S CODE PAN1455/1555	PANASONIC'S CODE ENW89815CxKF/ENW89815AxKF	DATE Datum	27.06.2011



**Figure 19.2 PAN1555 Recommended Land pattern
(Top-View not scaled)**

Dimensions in mm.

If you have no experience about the land pattern, this figure can guide you, but this information is given without any legal responsibility.

We recommend the same dimension for the solder paste screen.

The solder screen thickness depends on your production standard, we recommend 120µm to 150µm.

IMPORTANT:

Please be careful with the area under the module to avoid short cuts.

The bottom side from the PAN1455/1555 is fully coated, **also** the vias!

If you have any questions on this point, we are open to discuss your individual situation.

CLASSIFICATION Einstufung	PRODUCT SPECIFICATION Produktspezifikation	No. DS-1x55-2400-102	REV. 1.10
SUBJECT Thema	CLASS 2 BLUETOOTH MODULE Bluetooth Modul der Klasse 2	PAGE Seite	23 of 34
CUSTOMER'S CODE PAN1455/1555	PANASONIC'S CODE ENW89815CxKF/ENW89815AxKF	DATE Datum	27.06.2011

20. LABELLING DRAWING

Kennzeichnung des Moduls durch Label

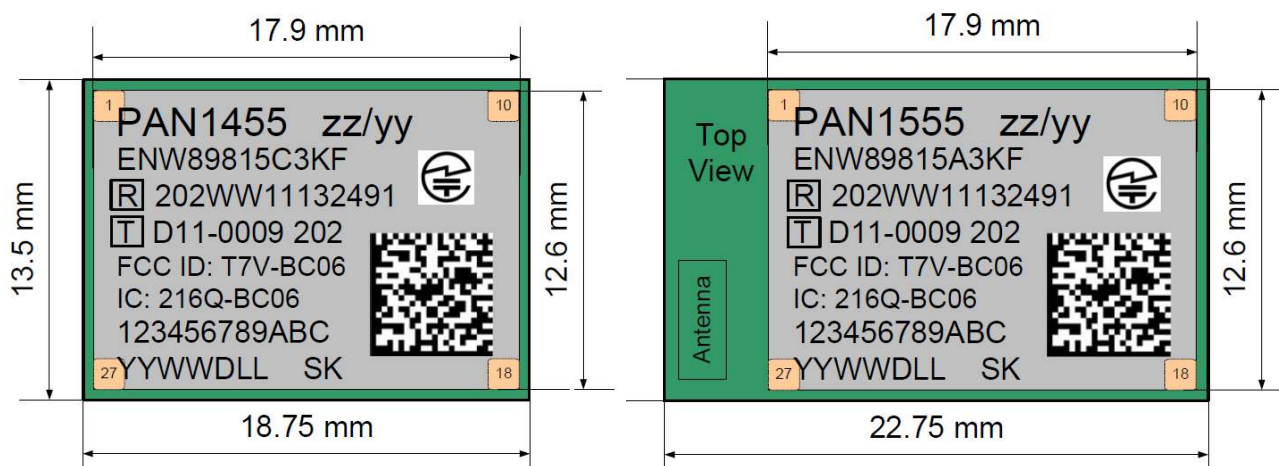

The information on the Module are marked by laser.

Information in the 2D-Barcode are in the format

- BT-address [12 signs, here 123456789ABC].
- Ordering number [12 signs, please refer also to chapter 24];
- The identifier for the software release (2 signs, here yy);
- Datecode: Year-Week-Day-Lotnumber [7 signs, here YYWWDLL].

All items are separated by a semicolon.

As a summary:

202WW11132491	Japan Radio Marking
D11-0009 202	Japan TTE Marking
FCC ID: T7V-BC06	FCC Certification Marking
zz	Identifier for the hardware version
yy	Identifier for the software version
123456789ABC	BT-Address
YYWWDLL	Datecode – Year-Week-Day-Lotnumber

CLASSIFICATION Einstufung	PRODUCT SPECIFICATION Produktspezifikation	No. DS-1x55-2400-102	REV. 1.10
SUBJECT Thema	CLASS 2 BLUETOOTH MODULE Bluetooth Modul der Klasse 2	PAGE Seite	24 of 34
CUSTOMER'S CODE PAN1455/1555	PANASONIC'S CODE ENW89815CxKF/ENW89815AxKF	DATE Datum	27.06.2011

21. SOFTWARE

Software

Standard platforms of PAN1455/1555 are available with several popular Bluetooth profiles, many other profiles are available on request. Before starting production, be certain to carefully review that the software meets your requirements.

21.1. SPP SOFTWARE

Serial Port Profile

Customized variants are available on request.

Please refer to Reference [1].

21.2. HDP SOFTWARE

The Health Device Profile

Please refer to Reference [1].

21.3. HID SOFTWARE

The Human Interface Device Software

Please refer to Reference [1].

21.4. HDP/SPP SOFTWARE

The combined HDP and SPP Profile enables customers to use both versions (SPP/HDP) in parallel.

Please refer to Reference [1].

21.5. OTHER PROFILES ARE AVAILABLE ON REQUEST.

22. CAUTIONS

Warnungen

Failure to do so may result in degrading of the product's functions and damage to the product.

22.1. DESIGN NOTES

Designhinweise

- (1) Please follow the condition written in this specification, especially the control signals of this module.
- (2) The supply voltage has to be free of ac ripple voltage, as for example from a battery or a low noise regulator output. For noisy supply voltages provide a decoupling circuit as for example a ferrite in series connection and a blocking capacitor to ground of at least 47uF directly at the module.
- (3) This product should not be stressed when installed.
- (4) Heat is the major cause of shortening the life of these products. Please keep this product away from heat.
Avoid assembly and use of the target equipment in conditions where the products' temperature may exceed the maximum allowable.
- (5) The supply voltage should not be exceeding or reverse, and should not carry noise and spike.
- (6) Please keep this product away from other high frequency circuits.

CLASSIFICATION Einstufung	PRODUCT SPECIFICATION Produktspezifikation	No. DS-1x55-2400-102	REV. 1.10
SUBJECT Thema	CLASS 2 BLUETOOTH MODULE Bluetooth Modul der Klasse 2	PAGE Seite	25 of 34
CUSTOMER'S CODE PAN1455/1555	PANASONIC'S CODE ENW89815CxKF/ENW89815AxKF	DATE Datum	27.06.2011

22.2. INSTALLATION NOTES

Verarbeitungshinweise

- (1) Reflow soldering is possible for twice on the condition in chapter 15. Please set up the temperature at the soldering portion of this product according to this reflow profile.
- (2) Carefully position the products so that their heat will not burn into printed circuit boards or affect the other components that are susceptible to heat.
- (3) Carefully locate these products so that their temperatures will not increase due to the effects of heat generated by neighboring components.
- (4) If a vinyl-covered wire comes into contact with the products, then the cover will melt and generate toxic gas, damaging the insulation. Never allow contact between the cover and these products to occur.
- (5) This product should not be stressed or vibrated when reflowed.
- (6) Keep the following conditions when you install this product for reparation by hand soldering.
- (7) Do not wash this product.
- (8) Refer to the recommended pattern when designing a board.
- (9) Pressing on parts of the metal cover or fastening objects to the metal cover is not allowed.

22.3. USAGE CONDITIONS NOTES

Benutzerhinweise

- (1) Take measure against static electricity. If pulses or other transient loads (a large load applied in a short time) are applied to the products, then before use, check and evaluate their operation when assembled on your products.
- (2) Do not use the fallen product.
- (3) Do not put on damage and dirt to the pin , and don't touch the electric components.
- (4) Be certain to follow the condition written in the ratings , about the power supply instruments applied to this product.
- (5) Electrode peeling strength: Do not add pressure of more than 4.9N when soldered on PCB
- (6) Pressing on parts of the metal cover or fastening objects to the metal cover is not allowed.
- (7) These products are intended for general purpose and standard use in general electronic equipment, such as home appliances, office equipment, information and communication equipment.

22.4. STORAGE NOTES

Lagerhinweise

- (1) The module may not be stressed mechanically during storage.
- (2) Do not store these products in the following conditions or the performance characteristics of the product, such as RF performance will be adversely affected:
 - Storage in salty air or in an environment with a high concentration of corrosive gas, such as Cl₂, H₂S, NH₃, SO₂, or NOX
 - Storage in direct sunlight
 - Storage in an environment where the temperature may be outside the range of 5°C to 35°C range, or where the humidity may be outside the 45 to 85% range.

CLASSIFICATION Einstufung	PRODUCT SPECIFICATION Produktspezifikation	No. DS-1x55-2400-102	REV. 1.10
SUBJECT Thema	CLASS 2 BLUETOOTH MODULE Bluetooth Modul der Klasse 2	PAGE Seite	26 of 34
CUSTOMER'S CODE PAN1455/1555	PANASONIC'S CODE ENW89815CxKF/ENW89815AxKF	DATE Datum	27.06.2011

- Storage of the products for more than one year after the date of delivery at your company if the avoidance all the above conditions (1) to (3) have been met.
- (3) Storage period: Please check the adhesive strength of the embossed tape and soldering after 6 months of storage.
- (4) Please keep this product away from water, poisonous gas and corrosive gas.
- (5) This product should not be stressed or shocked when transported.
- (6) Please follow the specification when piling up the packed crate (max. 10).

22.5. SAFETY CAUTIONS

Sicherheitshinweise

These specifications are intended to preserve the quality assurance of products as individual components.

Before use, check and evaluate their operation when mounted on your products. Abide by these specifications, without deviation when using the products. These products may short-circuit. If electrical shocks, smoke, fire, and/or accidents involving human life are anticipated when a short circuit occurs, then at least, provide the following failsafe functions, as a minimum.

- (1) Ensure the safety of the whole system by installing a protection circuit and a protection device.
- (2) Ensure the safety of the whole system by installing a redundant circuit or another system to prevent a single fault causing an unsafe status.

CLASSIFICATION Einstufung	PRODUCT SPECIFICATION Produktspezifikation	No. DS-1x55-2400-102	REV. 1.10
SUBJECT Thema	CLASS 2 BLUETOOTH MODULE Bluetooth Modul der Klasse 2	PAGE Seite	27 of 34
CUSTOMER'S CODE PAN1455/1555	PANASONIC'S CODE ENW89815CxKF/ENW89815AxKF	DATE Datum	27.06.2011

22.6. OTHER CAUTIONS

Weitere Hinweise

- (1) This specification sheet is copyrighted. Please do not open it to the third party.
- (2) Do not use this product of our company for another purpose.
- (3) Be sure to provide an appropriate fail-safe function on your product to prevent a second damage that may be caused by the abnormal function or the failure of our product.
- (4) This product has not been manufactured with any ozone chemical controlled under the Montreal Protocol.
- (5) These products are not intended for other uses, other than under the special conditions shown below. Before using these products under such special conditions, check their performance and reliability under the said special conditions carefully to determine whether or not they can be used in such a manner.
 - In liquid, such as water, salt water, oil, alkali, or organic solvent, or in places where liquid may splash.
 - In direct sunlight, outdoors, or in a dusty environment
 - In an environment where condensation occurs.
 - In an environment with a high concentration of harmful gas (e.g. salty air, HCl, Cl₂, SO₂, H₂S, NH₃, and NO_x)
- (6) If an abnormal voltage is applied due to a problem occurring in other components or circuits, replace these products with new products because they may not be able to provide normal performance even if their electronic characteristics and appearances appear satisfactory.
- (7) When you have any question or uncertainty, both of you and Panasonic sincerely cope with it.

CLASSIFICATION Einstufung	PRODUCT SPECIFICATION Produktspezifikation	No. DS-1x55-2400-102	REV. 1.10
SUBJECT Thema	CLASS 2 BLUETOOTH MODULE Bluetooth Modul der Klasse 2	PAGE Seite	28 of 34
CUSTOMER'S CODE PAN1455/1555	PANASONIC'S CODE ENW89815CxKF/ENW89815AxKF	DATE Datum	27.06.2011

23. PACKAGING Verpackung

23.1. EMBOSSED TAPE / BLISTERGURT

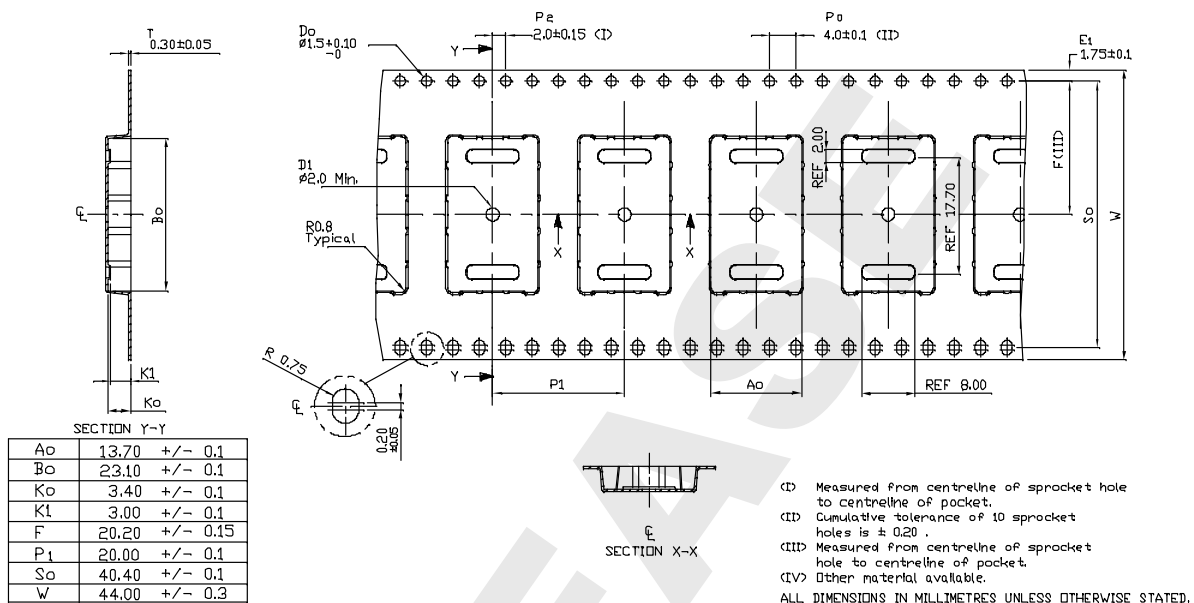

(1) Dimension of the tape PAN1555 / Abmessungen des Gurtes (EIAJ-tbd)

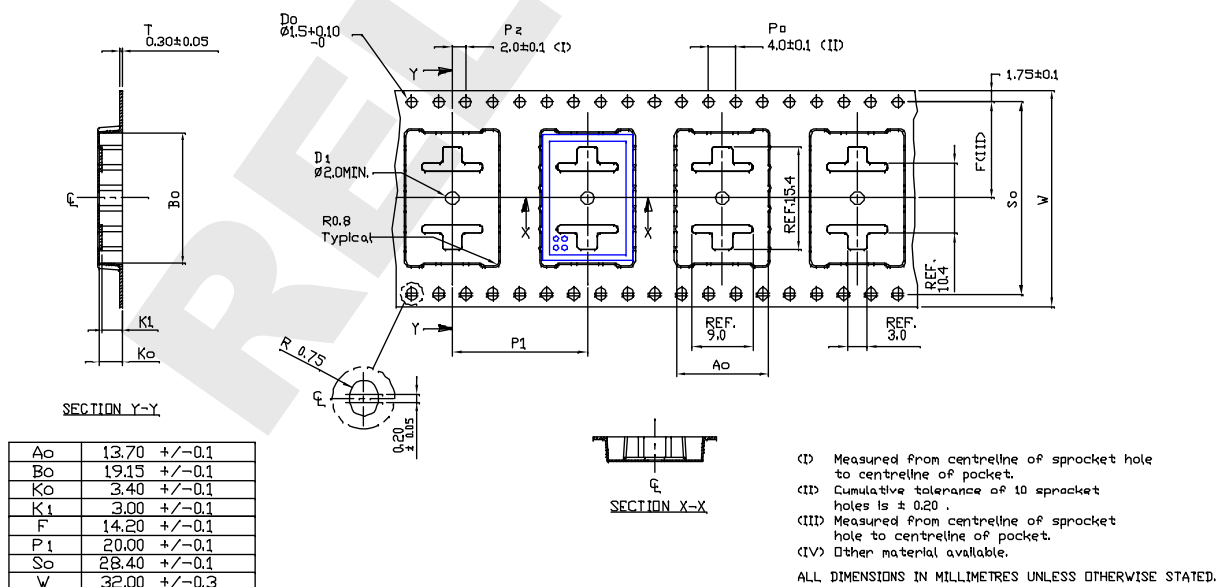

(2) Dimension of the tape PAN1455 / Abmessungen des Gurtes (EIAJ-tbd)

CLASSIFICATION Einstufung	PRODUCT SPECIFICATION Produktspezifikation	No. DS-1x55-2400-102	REV. 1.10
SUBJECT Thema	CLASS 2 BLUETOOTH MODULE Bluetooth Modul der Klasse 2	PAGE Seite	29 of 34
CUSTOMER'S CODE PAN1455/1555	PANASONIC'S CODE ENW89815CxKF/ENW89815AxKF	DATE Datum	27.06.2011

(3) Cover tape reel strength / Abzugskräfte Blistergurt Deckfolie

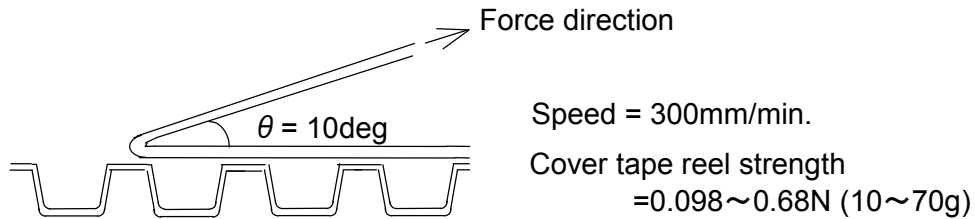

(4) Empty hollow / leere Taschen

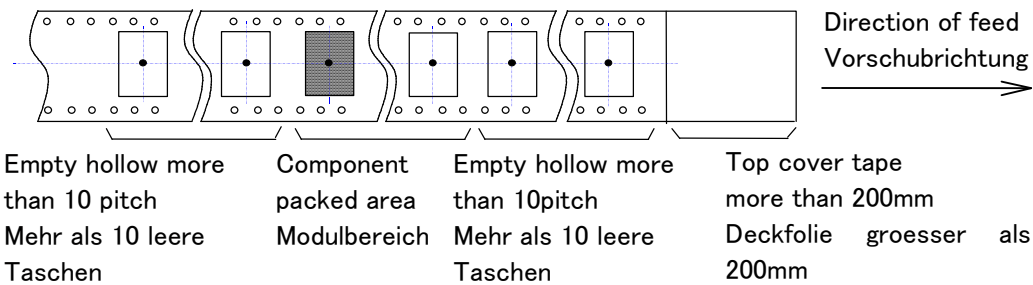

Empty hollow in component packed area shall be less than two per reel and those hollows shall not be consecutive.

Es dürfen minimal 2 leere Taschen im Bereich der Komponenten vorhanden sein, diese dürfen aber nicht aufeinander folgen.

23.2. COMPONENT DIRECTION
Komponentenanordnung

Top cover tape shall not be found on reel holes and shall not stick out from reel.

Deckfolien darf nicht durch die Löcher der Spule und nicht außerhalb der Spule geführt werden.

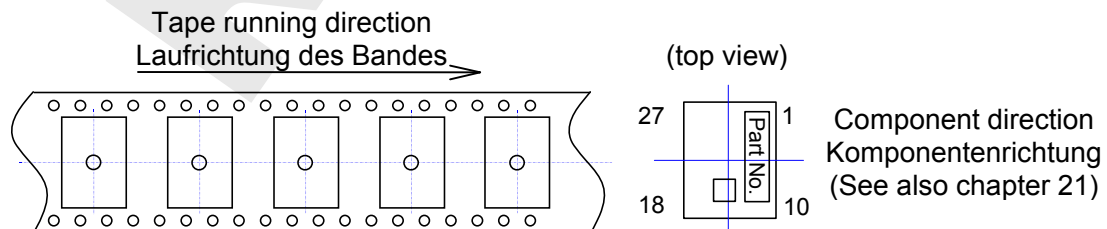

Figure 1

CLASSIFICATION Einstufung	PRODUCT SPECIFICATION Produktspezifikation	No. DS-1x55-2400-102	REV. 1.10
SUBJECT Thema	CLASS 2 BLUETOOTH MODULE Bluetooth Modul der Klasse 2	PAGE Seite	30 of 34
CUSTOMER'S CODE PAN1455/1555	PANASONIC'S CODE ENW89815CxKF/ENW89815AxKF	DATE Datum	27.06.2011

23.3. REEL DIMENSION
Abmaße der Rolle

- (1) Quantity per reel : 500 pieces
Anzahl pro Rolle : 500 Stück
- (2) Marking : Customer's part No. / Quantity / Lot No. and Our part# with bar-code shall be on the reel.
Kennzeichnung : Kundennummer / Anzahl / Losnummer und unsere Komponentenummer als Barcode wird auf die Rolle gedruckt
Refer to figure 2
Bezugnehmend zur Zeichnung 2

23.4. PACKAGE
Umverpackung

- (1) Package box : 1 or 2 reel (depends on quantity)
Paketbox.: 1 oder 2 Rollen (abhängig von der Liefermenge)
- (2) Marking : Customer's part No. / Quantity / Lot No. and Our part# with bar-code shall be on the package box.
Kennzeichnung : Kundennummer / Anzahl / Losnummer und unsere Komponentenummer als Barcode wird auf die Verpackung gedruckt
Refer to figure 2 and 3
Bezugnehmend zur Zeichnung 2 und 3

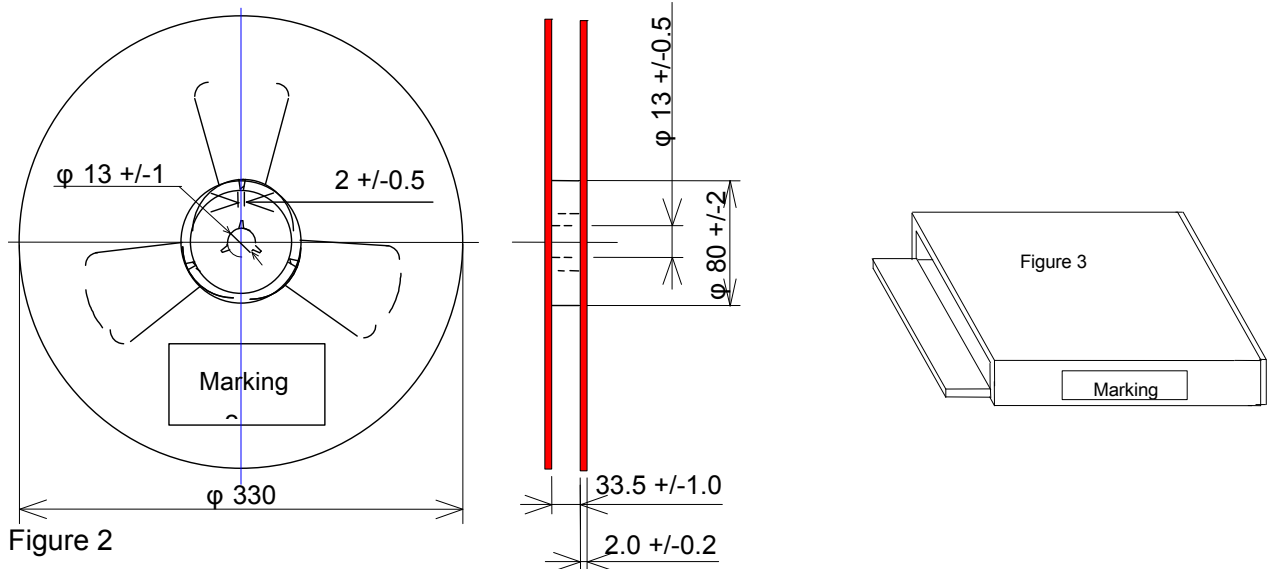

CLASSIFICATION Einstufung	PRODUCT SPECIFICATION Produktspezifikation	No. DS-1x55-2400-102	REV. 1.10
SUBJECT Thema	CLASS 2 BLUETOOTH MODULE Bluetooth Modul der Klasse 2	PAGE Seite	31 of 34
CUSTOMER'S CODE PAN1455/1555	PANASONIC'S CODE ENW89815CxKF/ENW89815AxKF	DATE Datum	27.06.2011

24. ORDERING INFORMATION

Bestellinformationen

Ordering part number	Description
ENW89815C3KF	PAN1455 BT 3.0 256kByte Flash Memory, without Antenna Software: SPP ⁽¹⁾
ENW89815A3KF	PAN1555 BT 3.0 256kByte Flash Memory, with Antenna Software: SPP ⁽¹⁾
ENW89815A4KF	PAN1555 BT 3.0 256kByte Flash Memory, with Antenna Software: HDP ⁽¹⁾
ENW89815A5KF	PAN1555 BT 3.0 256kByte Flash Memory, with Antenna Software: SPP/HDP ⁽¹⁾
ENW89815C4KF	PAN1455 BT 3.0 256kByte Flash Memory, without Antenna Software: HDP ⁽¹⁾
ENW89815C5KF	PAN1455 BT3.0 256kByte Flash Memory, without Antenna Software: SPP/HDP ⁽¹⁾

Notes:

(1) This software is licensed by the company Stollmann please refer to [1] .

25. ROHS DECLARATION

RoHS-Erklärung

Declaration of environmental compatibility for supplied products:

Hereby we declare to our best present knowledge based on declaration of our suppliers that this product do not contain by now the following substances which are banned by Directive 2002/95/EC (RoHS) or if contain a maximum concentration of 0,1% by weight in homogeneous materials for

- Lead and lead compounds
- Mercury and mercury compounds
- Chromium (VI)
- PBB (polybrominated biphenyl) category
- PBDE (polybrominated biphenyl ether) category

And a maximum concentration of 0,01% by weight in homogeneous materials for

- Cadmium and cadmium compounds

26. DATA SHEET STATUS

Datenblatt Status

This data sheet contains the final specification (RELEASE).

Panasonic reserves the right to make changes at any time without notice in order to improve design and supply the best possible product.

Supplementary data will be published at a later date.

Please consult the most recently issued data sheet before initiating or completing a design.

CLASSIFICATION Einstufung	PRODUCT SPECIFICATION Produktspezifikation	No. DS-1x55-2400-102	REV. 1.10
SUBJECT Thema	CLASS 2 BLUETOOTH MODULE Bluetooth Modul der Klasse 2	PAGE Seite	32 of 34
CUSTOMER'S CODE PAN1455/1555	PANASONIC'S CODE ENW89815CxKF/ENW89815AxKF	DATE Datum	27.06.2011

27. REGULATORY INFORMATION

27.1. FCC NOTICE



The device PAN1555, including the ceramic antenna and also the SMD type PAN1455, including with the antennas, which are listed in 27.5, complies with Part 15 of the FCC Rules. The device meets the requirements for modular transmitter approval as detailed in FCC public Notice DA00-1407.transmitter

Operation is subject to the following two conditions: (1) This device may not cause harmful interference, and (2) This device must accept any interference received, including interference that may cause undesired operation.

27.2. CAUTION



The FCC requires the user to be notified that any changes or modifications made to this device that are not expressly approved by Panasonic Electronic Devices Europe GmbH may void the user's authority to operate the equipment.

This equipment has been tested and found to comply with the limits for a Class B digital device, pursuant to Part 15 of the FCC Rules. These limits are designed to provide reasonable protection against harmful interference in a residential installation. This equipment generates, uses and can radiate radio frequency energy and, if not installed and used in accordance with the instructions, may cause harmful interference to radio communications. However, there is no guarantee that interference will not occur in a particular installation. If this equipment does cause harmful interference to radio or television reception, which can be determined by turning the equipment off and on, the user is encouraged to try to correct the interference by one or more of the following measures:

- Reorient or relocate the receiving antenna.
- Increase the separation between the equipment and receiver.
- Connect the equipment into an outlet on a circuit different from that to which the receiver is connected.
- Consult the dealer or an experienced radio/TV technician for help

27.3. LABELING REQUIREMENTS



The Original Equipment Manufacturer (OEM) must ensure that FCC labeling requirements are met. This includes a clearly visible label on the outside of the OEM enclosure specifying the appropriate Panasonic FCC identifier for this product as well as the FCC Notice above. The FCC identifier are **FCC ID: T7V-BC06**. This FCC identifier is valid for all versions, for details, please see the chapter 24. Ordering Information.

In any case end product must be labelled exterior with "Contains FCC ID: T7V-BC06"

CLASSIFICATION Einstufung	PRODUCT SPECIFICATION Produktspezifikation	No. DS-1x55-2400-102	REV. 1.10
SUBJECT Thema	CLASS 2 BLUETOOTH MODULE Bluetooth Modul der Klasse 2	PAGE Seite	33 of 34
CUSTOMER'S CODE PAN1455/1555	PANASONIC'S CODE ENW89815CxKF/ENW89815AxKF	DATE Datum	27.06.2011

27.4. ANTENNA WARNING



The related part number for this device is PAN1455 with SMD pad). For details, please see the chapter 24. Ordering Information. This device are tested with a standard SMA connector and with the antennas listed below. When integrated in the OEMs product, these fixed antennas require installation preventing end-users from replacing them with non-approved antennas. Any antenna exceeding 2dBi not in the following table must be tested to comply with FCC Section 15.203 for unique antenna connectors and Section 15.247 for emissions. The FCC identifier for this device with the antenna listed in item 1 are the same (FCC ID: T7V-BC06).

27.5. APPROVED ANTENNA LIST

Note: We are able to qualify your antenna and will add to this list as that process is completed.

Item	Part Number	Manufacturer	Frequency Band	Type	Gain (dBi)
1	WIMO17010.10	Wimo	2.4GHz	ROD	+2
2	2450AT42B100	Johanson	2.4GHz	SMD	-1.5

27.6. RF EXPOSURE PAN1455/PAN1555



To comply with FCC RF Exposure requirements, the Original Equipment Manufacturer (OEM) must ensure that the approved antenna in the previous table must be installed.

The preceding statement must be included as a CAUTION statement in manuals for products operating with the approved antennas in the previous table to alert users on FCC RF Exposure compliance.

Any notification to the end user of installation or removal instructions about the integrated radio module is not allowed.

The radiated output power of PAN1455 with mounted ceramic antenna (FCC ID: T7V-BC06) is far below the FCC radio frequency exposure limits. Nevertheless, the PAN1455 shall be used in such a manner that the potential for human contact during normal operation is minimized.

End users may not be provided with the module installation instructions. OEM integrators and end users must be provided with transmitter operating conditions for satisfying RF exposure compliance.

27.7. INDUSTRY CANADA CERTIFICATION

PAN1455/PAN1555 comply with the regulatory requirements of Industry Canada (IC), license:

IC: 216Q-BC06

Manufacturers of mobile, fixed or portable devices incorporating this module are advised to clarify any regulatory questions and ensure compliance for SAR and/or RF exposure limits. Users can obtain Canadian information on RF exposure and compliance from

www.ic.gc.ca

This device has been designed to operate with the antenna listed in section 27.5 above, having a maximum gain of 2.0 dBi. Antennas not included in this list or having a gain greater than 2.0 dBi are strictly prohibited for use with this device. The required antenna impedance is 50 ohms. The antenna used for this transmitter must not be colocated or operating in conjunction with any other antenna or transmitter.

CLASSIFICATION Einstufung	PRODUCT SPECIFICATION Produktspezifikation	No. DS-1x55-2400-102	REV. 1.10
SUBJECT Thema	CLASS 2 BLUETOOTH MODULE Bluetooth Modul der Klasse 2	PAGE Seite	34 of 34
CUSTOMER'S CODE PAN1455/1555	PANASONIC'S CODE ENW89815CxKF/ENW89815AxKF	DATE Datum	27.06.2011

28. RELATED DOCUMENTS

Mitgeltende Dokumente

[1] Stollmann Firmware updates/support:

<http://www.stollmann.de/de/support/downloads/bluetooth-adapter/bluemod-p2xg2.html>

29. GENERAL INFORMATION

Allgemeine Informationen

© Panasonic Electronic Devices Europe GmbH 2009.

All rights reserved.

This product description does not lodge the claim to be complete and free of mistakes.

Please contact the related product manager in every case.

If we deliver ES samples to the customer, these samples have the status Engineering Samples. This means, the design of this product is not yet concluded. Engineering Samples may be partially or fully functional, and there may be differences to be published Data Sheet.

Engineering Samples are not qualified and are not to be used for reliability testing or series production.

Disclaimer:

Customer acknowledges that samples may deviate from the Data Sheet and may bear defects due to their status of development and the lack of qualification mentioned above.

Panasonic rejects any liability or product warranty for Engineering Samples. In particular, Panasonic disclaims liability for damages caused by

- the use of the Engineering Sample other than for Evaluation Purposes, particularly the installation or integration in an other product to be sold by Customer,
- deviation or lapse in function of Engineering Sample,
- improper use of Engineering Samples.

Panasonic disclaims any liability for consequential and incidental damages.

In case of any questions, please contact your local sales partner or the related product manager.

30. LIFE SUPPORT POLICY

Politik für Lebenserhaltungssysteme

This Panasonic product is not designed for use in life support appliances, devices, or systems where malfunction can reasonably be expected to result in a significant personal injury to the user, or as a critical component in any life support device or system whose failure to perform can be reasonably expected to cause the failure of the life support device or system, or to affect its safety or effectiveness. Panasonic customers using or selling these products for use in such applications do so at their own risk and agree to fully indemnify Panasonic for any damages resulting.