

DH-7J
RELAY-SPDT
HERMETICALLY SEALED

REVISIONS

REV.	ECO	DESCRIPTION	DATE	APPROVED
AB	09-023188	ITEM 8 WAS -248, ITEM 9 WAS -138, ITEM 10 WAS -821	13AUG2009	CB

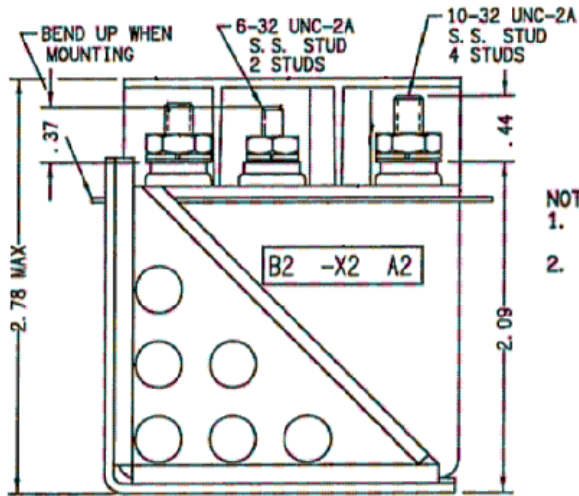
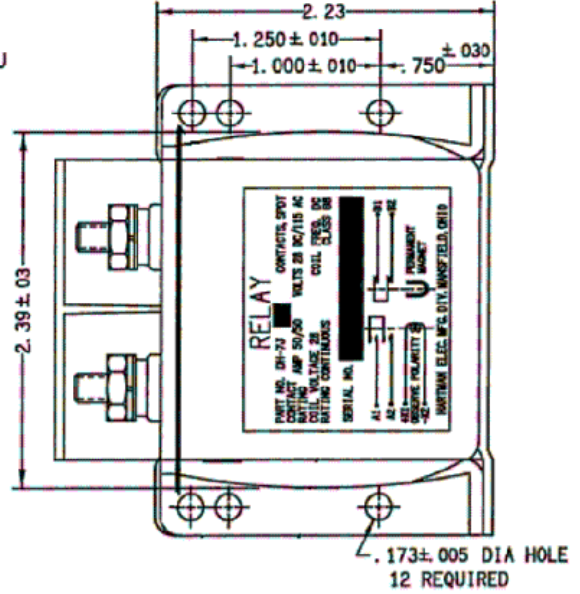
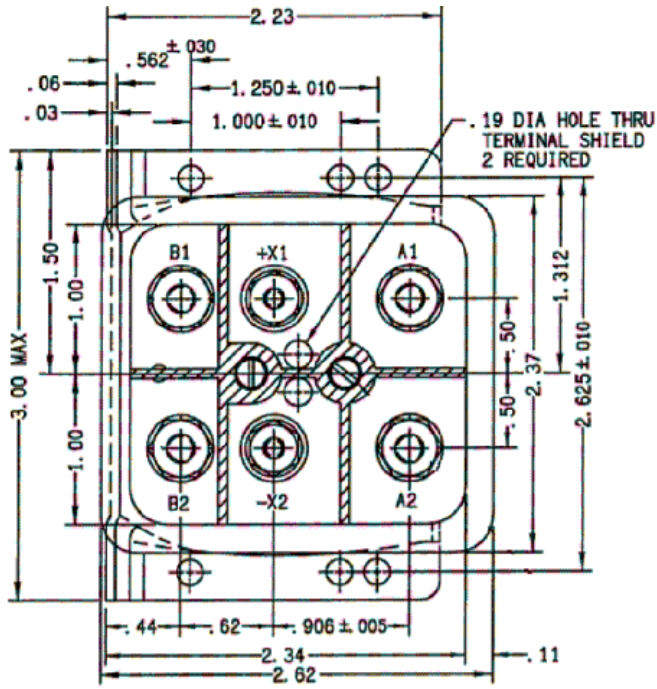

- NOTES:
- CONTACTOR MEETS THE MATERIALS AND WORKMANSHIP REQUIREMENTS OF MIL-R-6106.
 - MOUNTING SURFACE SHALL PROVIDE ELECTRICAL GROUND.

ALL DIMENSIONS ARE IN INCHES



TE CONNECTIVITY
175 N. DIAMOND STREET MANSFIELD,
OHIO 44902

TITLE

RELAY-SPDT
HERMETICALLY SEALED

TE P.N.

8-1616927-9

DWG NO.

DH-7J

DS

DATA SHEET

CAGE CODE
74063

SCALE
NONE

SHEET
1 OF 2

REV
AB

GENERAL SPECIFICATION

CONSTRUCTION	HERMETICALLY SEALED
CONTACTS	SPDT DOUBLE BREAK
RES., 115V, 400HZ, OR 28 VDC	50 AMP
IND., 115V, 400HZ, OR 28 VDC	50 AMP
MOTOR, 115V, 400HZ, OR 28 VDC	50 AMP
COIL DATA	
VOLTAGE, NOM.	24 TO 28 VDC
VOLTAGE, MAX.	30 VDC
CURRENT AT 25° C	.5 AMP MAX
PICKUP AT 25° C	18 VDC MAX
DROPOUT	7 +0/-5.5 VDC
AMBIENT TEMP.	120° C
RATED DUTY	CONTINUOUS
VIBRATION	15G, 300-600 HZ
	14G, 600-700 HZ
	10G, 5-1500 HZ
ALTITUDE	80,000 FT
MINIMUM CYCLES	50,000
MAX. WEIGHT	13-1/2 OZ

SCHEMATIC

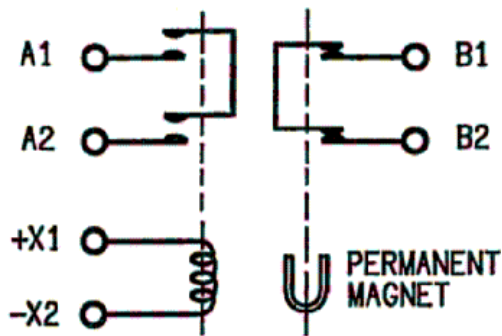

TE CONNECTIVITY
175 N, DIAMOND STREET MANSFIELD,
OHIO 44902

TITLE

RELAY-SPDT
HERMETICALLY SEALED

TE P.N.

8-1616927-9

DWG NO.

DH-7J

DS

DATA SHEET

CAGE CODE
74063

SCALE
NONE

SHEET
2 OF 2

REV
AB