

- $\triangle 1$ HOUSING: LIQUID CRYSTAL POLYMER, COLOR BLACK.
CONTACTS: HIGH RELIABILITY COPPER ALLOY.
GROUND BUSES: PHOSPHOR BRONZE ALLOY, UNS C51100.
- $\triangle 2$ CONTACTS & GROUND BUSES: NICKEL UNDERPLATE ALL OVER,
MATING SURFACE PLATED TO MEET LEVEL 1 PERFORMANCE
REQUIREMENTS OF TE PRODUCT SPECIFICATION 108-1422,
SOLDER TAILS PLATED MATTE TIN.
- $\triangle 3$ DATE CODE MARKED IN AREA INDICATED ON SIDE OPPOSITE
POSITION #1.
- $\triangle 4$ ONE GROUND BUS WITH 5 TAILS PER EACH MODULE.
- $\triangle 5$ TOLERANCE NON-ACCUMULATIVE.
- $\triangle 6$ FOR STANDARD APPLICATIONS, ORIENTATION HOLE TO BE
 $\phi .094 \pm .002 [2.39 \pm 0.05]$.
FOR SLIP-FIT APPLICATIONS, ORIENTATION HOLE TO BE
 $\phi .079 \pm .001 [2.00 \pm 0.03]$.
- $\triangle 7$ OBSOLETE

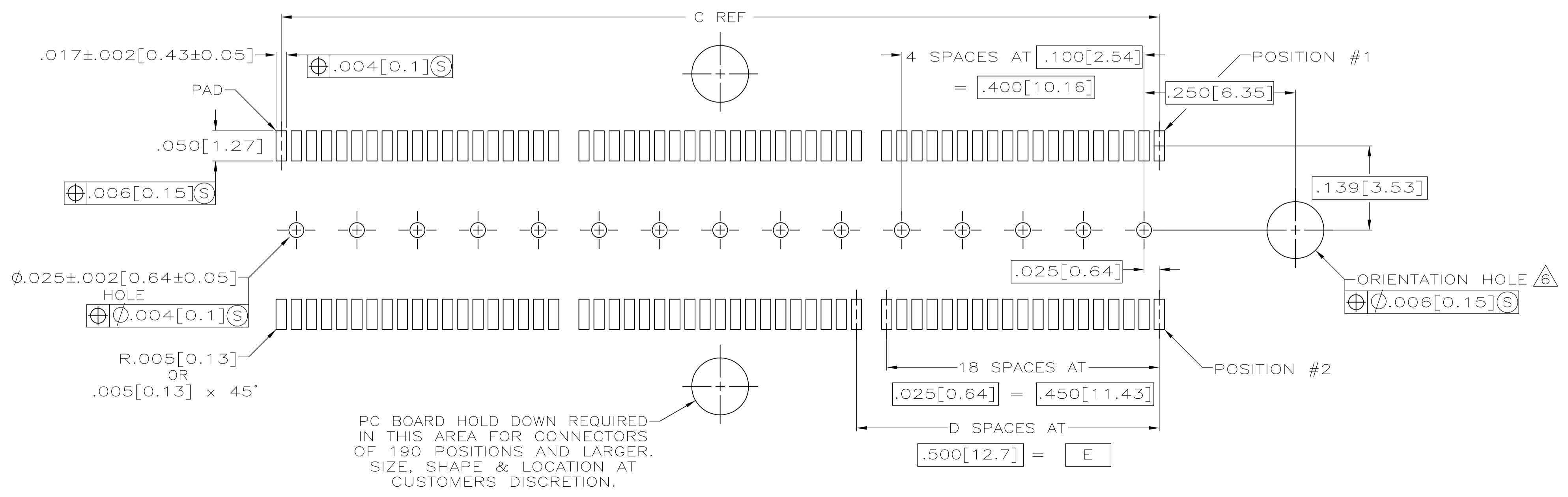
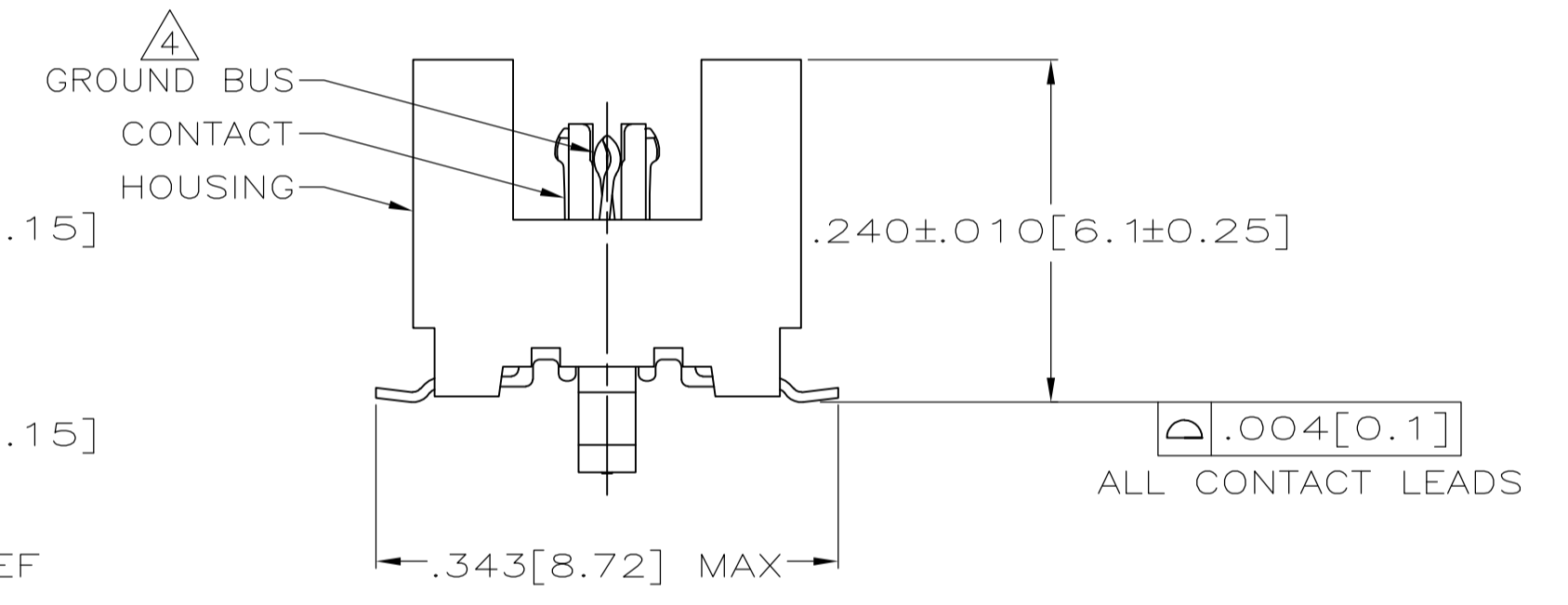
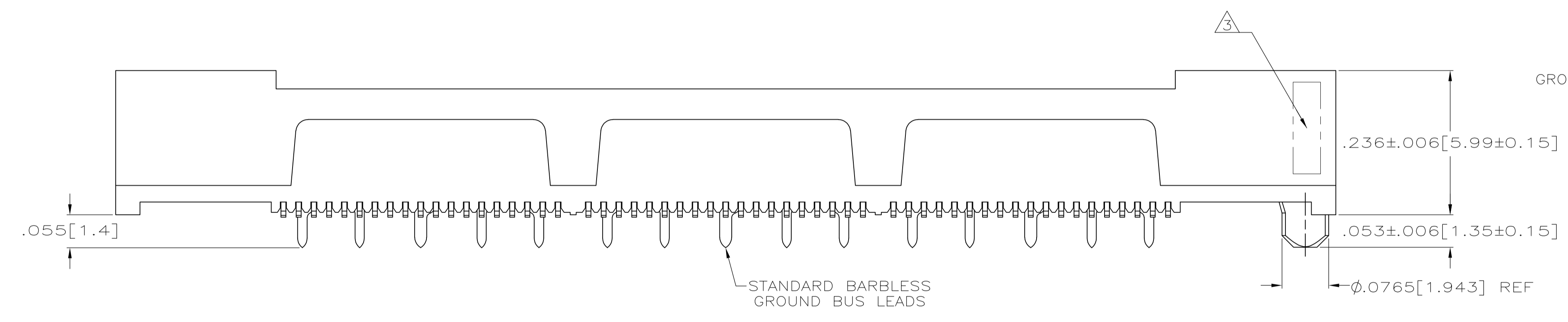

PC BOARD HOLD DOWN REQUIRED
IN THIS AREA FOR CONNECTORS
OF 190 POSITIONS AND LARGER.
SIZE, SHAPE & LOCATION AT
CUSTOMERS DISCRETION.

RECOMMENDED PC BOARD LAYOUT
(VIEWED FROM CONNECTOR SIDE)

4.724 [120]	3.000 [76.2]	6	3.450 [87.63]	3.900 [99.06]	4.000 [101.6]	266	5767110-7
4.094 [104]	2.500 [63.5]	5	2.950 [74.93]	3.400 [86.36]	3.500 [88.9]	228	5767110-6
3.465 [88]	2.000 [50.8]	4	2.450 [62.23]	2.900 [73.66]	3.000 [76.2]	190	5767110-5
3.465 [88]	1.500 [38.1]	3	1.950 [49.53]	2.400 [60.96]	2.500 [63.5]	152	5767110-4
2.835 [72]	1.000 [25.4]	2	1.450 [36.83]	1.900 [48.26]	2.000 [50.8]	114	5767110-3
2.205 [56]	.500 [12.7]	1	.950 [24.13]	1.400 [35.56]	1.500 [38.1]	76	5767110-2
1.732 [44]	.000 [0]	0	.450 [11.43]	.900 [22.86]	1.000 [25.4]	38	5767110-1
F	E	D	C	B	A	NO OF POS	PART NUMBER

THIS DRAWING IS A CONTROLLED DOCUMENT.

DWN S. ATTADIA 27 OCT 04	Tyco Electronics Tyco Electronics Corporation Harrisburg, Pa 17105-3608
CHK D. DIXON 27 OCT 04	
APRD D. DIXON 27 OCT 04	NAME RECEPTACLE ASSEMBLY, VERTICAL, .025[0.64]CL, GULL WING LEADS, MICTOR
PRODUCT SPEC 108-1422	SIZE A1
APPLICATION SPEC 114-11004	DRAWING NO 00779
RESTRICTED TO	SCALE 8:1
MATERIAL $\triangle 1$	FINISH $\triangle 2$
WEIGHT -	SHEET 1 OF 1
CUSTOMER DRAWING	REV B