

| ITEM # | PART # | QTY | DESCRIPTION |
|--------|-------------|-----|----------------------|
| 1 | MAJ-60-12 | 1 | OM PLUG HOUSING |
| 2 | MAJ-60-08P | 1 | JACK INSERT, 10 COND |
| 3 | MAP-60-06 | 1 | STRAIN RELIEF |
| 4 | MAP-60-07 | 1 | WASHER, RUBBER |
| 5 | MAP-60-08 | 1 | NUT, ADAPTER |
| 6 | AJ-117BR-9 | 1 | BUSHING - 1/4 |
| 7 | AJ-117BR-10 | 1 | WASHER - 1/4 |
| 8 | AJ-117BR-15 | 1 | SPRING - 1/4 |
| 9 | AJ-117BR-11 | 1 | STUD, SHELL - 1/4 |

B MAJ-60-30CP

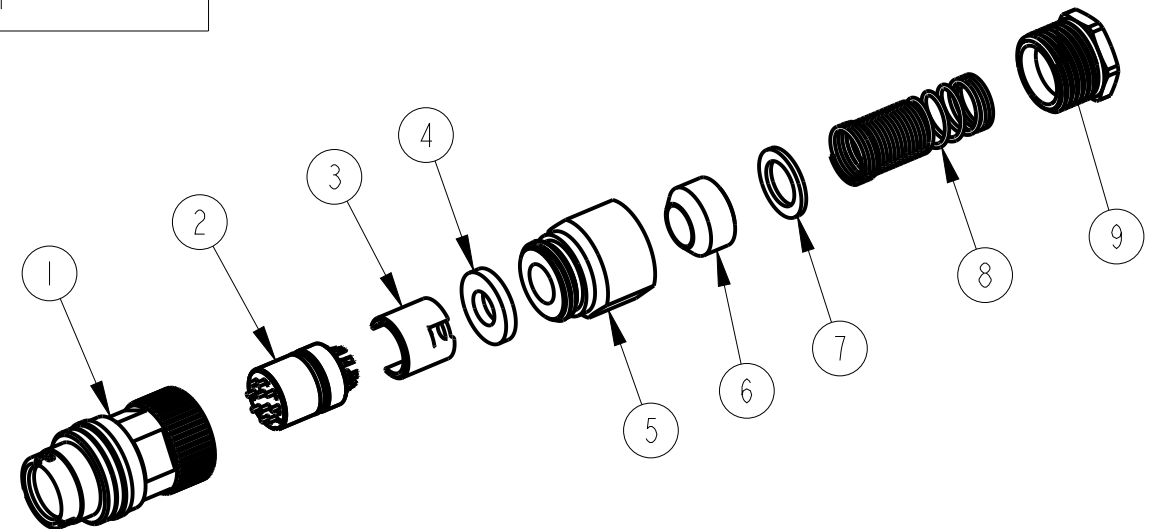

NOTES:
1) ORANGE ALIGNMENT DIMPLE

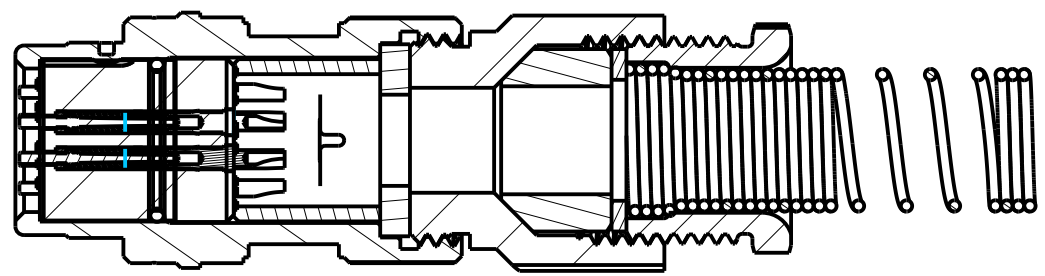
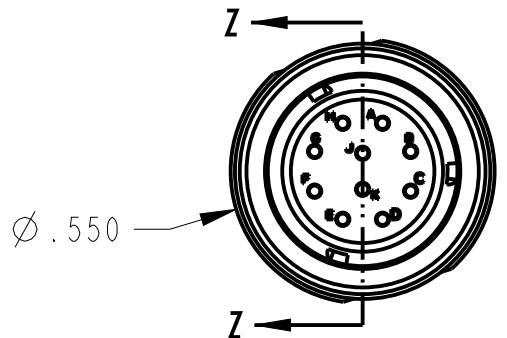
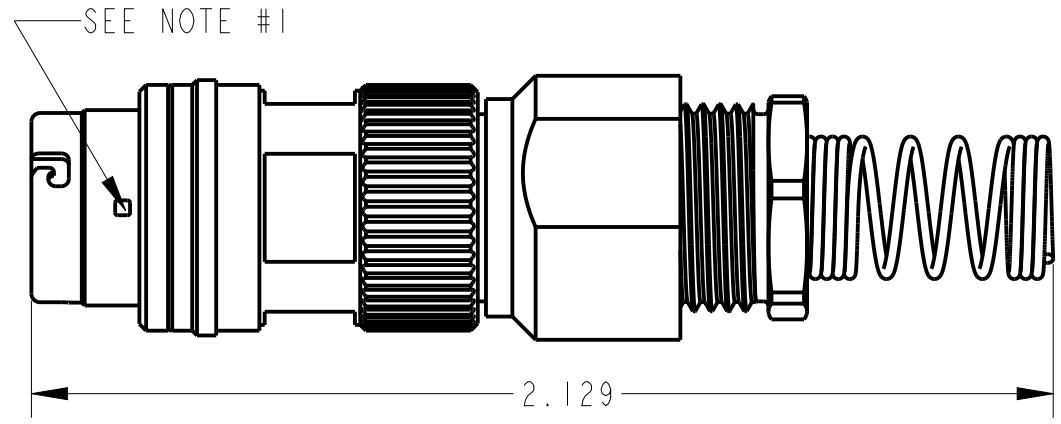

SECTION Z-Z

THIS DOCUMENT CONTAINS PROPRIETARY INFORMATION OF NEXUS, INCORPORATED AND SUCH INFORMATION MAY NOT BE DISCLOSED TO OTHERS FOR ANY PURPOSE OR USED FOR ANY PURPOSE WITHOUT THE WRITTEN CONSENT OF NEXUS.

| | | | | | | | |
|------------|--------------------------------------|------|------------|------|---|----------|-------------------------|
| DWN. BY | | HR | DATE | | 8/11/17 | MATERIAL | |
| CHECKED BY | | | DATE | | | FINISH | |
| APPR. BY | | | DATE | | | WEIGHT | SCALE = 2.00 : 1 |
| C | REPLACE CONTACT INSERT WAS MAJ-60-01 | 1259 | 10/11 2019 | BAM | TITLE | | NEXUS STAMFORD, CONN |
| B | CHG: MAP-60-06 TO MAP-60-06C | 243 | 9/21 2017 | HR | 10-COND RECEPTACLE $\phi .250$ CABLE | | |
| A | NEW RELEASE | | 8/11 2017 | HR | DO NOT SCALE DWG. | | SIZE B |
| LET. | REVISION | CN # | DATE | CHK. | SHEET 1 OF 1 | | DWG. NO. MAJ-60-30CP |

UNLESS OTHERWISE SPECIFIED:
DIMENSIONS ARE IN INCHES &/OR [mm]
TOLERANCES:
DECIMAL: .XX[X.X] .XXX[X.XX]
 ±.01[0.3] ±.003[0.08]
FRACTION: X/X ANGLES: .X
 ±1/64 ±.5°