

boostedNFC analog front-end with active load modulation

Data brief

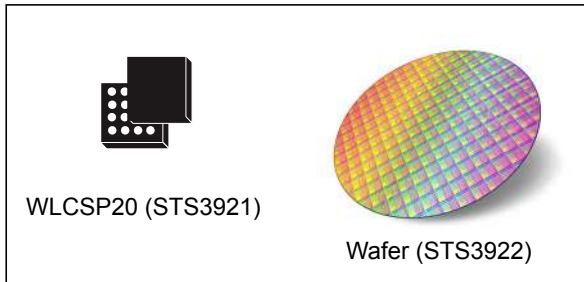

Features

- Supply voltage range from 2.7 V to 3.6 V
- Operating temperature: -25 °C to 85 °C
- Extended read range in card emulation mode with antennas below 100 mm²
 - boostedNFC technology, based on active load modulation
 - Internal timing defined by VCO locked to reader frequency
 - Delay compensation and synchronization to ensure transmission in phase with reader field
 - Adjustable initial phase
 - Low-impedance output driver
 - Automatic output power control to avoid communication holes
- Automatic antenna tuning (STS3922 only)
- High degree of Interoperability
 - Automatic power control
 - Automatic gain control
- EMVCo™, ISO/IEC 14443, JIS (X) 6319-4 compliance for full interoperability with existing payment and ticketing infrastructure. Card emulation supporting:
 - ISO/IEC 14443 Type A 106 kbps
 - ISO/IEC 14443 Type B 106 kbps
 - FeliCa™ 212 kbps

- Interface to dual-interface microcontroller to boost card emulation performance
 - Contactless or NFC-WI interface to SE
 - Power supply switch for SE
- Low power consumption
 - Low power in Wakeup mode
 - Mechanism to power the SE at field detection
- Simple system integration
 - SPI interface and on-chip EEPROM for operating option settings
- Delivery forms:
 - STS3922 delivered as bare dice
 - STS3921 in small footprint, with low overall cost of ownership: wafer-level chip-scale package (WLCSP)

Applications

boostedNFC products are ideal for NFC applications on small-footprint devices, such as wearable devices.

boostedNFC products are intended for two types of embedded applications:

- In combination with a dual-interface chip such as an ST31G480 secure microcontroller to allow payment and ticketing on smart devices
- In combination with RFID tag ICs to allow specific features such as Bluetooth®/Wi-Fi® pairing through NFC, and communication to a microcontroller through an RF interface.

1 Description

The STS3921 and STS3922 products are a family of advanced analog front-ends with ST's unique boostedNFC technology. They are ideal for applications that require the card emulation functionality, but are environmentally challenged or have limited space for the antenna. This solution allows for a simpler design than the conventional NFC controller-based architecture, and occupies a board footprint around one-third smaller.

The boostedNFC technology from ST overcomes the main difficulties seen in these applications when using passive load modulation through generating a tag response with active transmission. This allows for tag-to-reader communication at coupling factors that are one order of magnitude lower than conventional methods. When compared to passive NFC implementations, boostedNFC increases the usable operating volume by up to 900%. The consumer's experience during contactless transactions is easy, quick, and completely reliable, whether for payments in shops, ticketing in metro/urban mass transit infrastructures, or access control.

boostedNFC products are compliant with the ISO 14443 and FeliCa™ protocols. An onboard EEPROM allows optimal operational settings to be selected and programmed by the customer.

The STS3921 is provided in 20-bump wafer-length Chip-scale package (WLCSP20) whereas the STS3922 are delivered as bare dice.

In order to meet environmental requirements, ST offers this device in different grades of ECOPACK® packages, depending on their level of environmental compliance. ECOPACK® specifications, grade definitions and product status are available at: www.st.com. ECOPACK® is an ST trademark.

2 Software and hardware development package

ST provides a comprehensive development and design package to:

- Simplify software integration: ST lowers the cost for developers by providing multi-application support with optimized solutions including intuitive SDK platforms for integrating contactless services around any microcontroller wearable device architecture.
- Simplify hardware integration: ST provides a set of reference designs, expansion boards and design guidelines.
- Simplify deployment: ST provides turnkey solution partnership with OS vendors and precertification services to help to reduce the time to market as well as development costs.

3 STS3921/STS3922 block diagrams and implementation schematics

Figure 1 and Figure 2 show the block diagrams of the STS3921 and STS3922 devices, respectively.

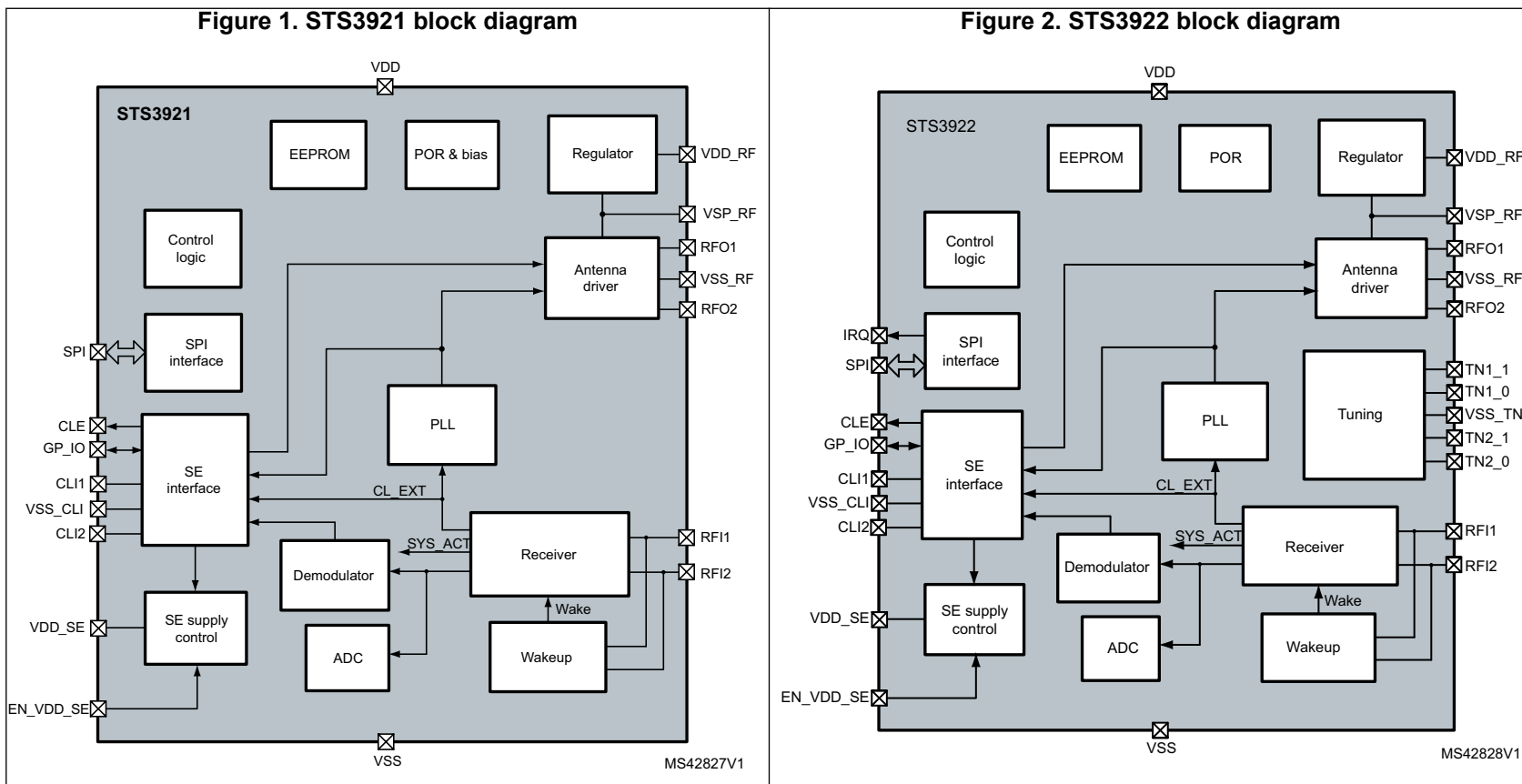
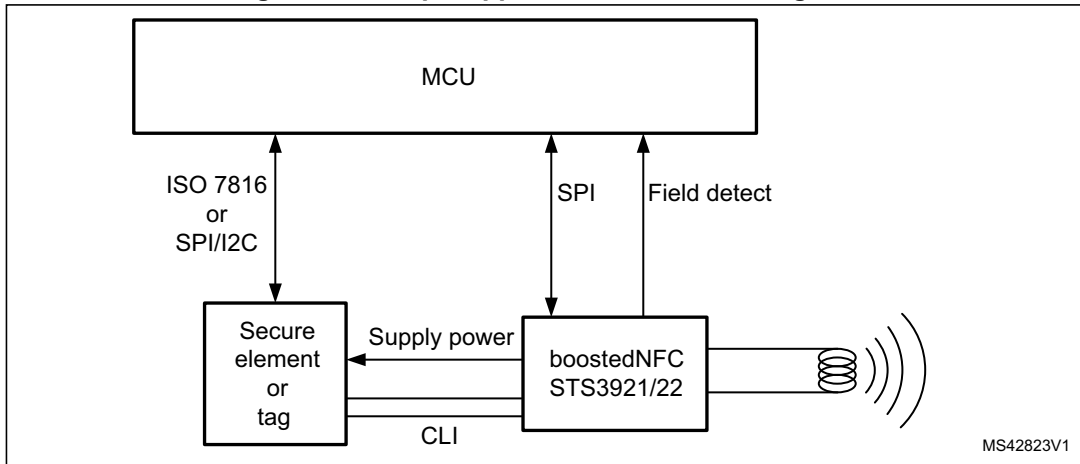

Figure 3 illustrates how the STS3921 and STS3922 devices are connected in applications involving a secure element or an RFID tag.

Figure 3. Example application schematic diagram



4 Revision history

Table 1. Document revision history

Date	Revision	Changes
29-Nov-2016	1	Initial release.

IMPORTANT NOTICE – PLEASE READ CAREFULLY

STMicroelectronics NV and its subsidiaries (“ST”) reserve the right to make changes, corrections, enhancements, modifications, and improvements to ST products and/or to this document at any time without notice. Purchasers should obtain the latest relevant information on ST products before placing orders. ST products are sold pursuant to ST’s terms and conditions of sale in place at the time of order acknowledgment.

Purchasers are solely responsible for the choice, selection, and use of ST products and ST assumes no liability for application assistance or the design of Purchasers’ products.

No license, express or implied, to any intellectual property right is granted by ST herein.

Resale of ST products with provisions different from the information set forth herein shall void any warranty granted by ST for such product.

ST and the ST logo are trademarks of ST. All other product or service names are the property of their respective owners.

Information in this document supersedes and replaces information previously supplied in any prior versions of this document.

© 2016 STMicroelectronics – All rights reserved

