



# EVALUATING THE AD9656 ANALOG-TO-DIGITAL CONVERTER

## Preface

This user guide describes the [AD9656](#) evaluation board [AD9656EBZ](#), which provides the support circuitry required to operate the ADC in its various modes and configurations. The application software used to interface with the device is also described.

The [AD9656](#) data sheet provides additional information and should be consulted when using the evaluation board. Documents and software tools are available at [AD9656](#) and [www.analog.com/hsadcevalboard](http://www.analog.com/hsadcevalboard). For additional information or questions, send an email to [highspeed.converters@analog.com](mailto:highspeed.converters@analog.com).

## Typical Measurement Setup

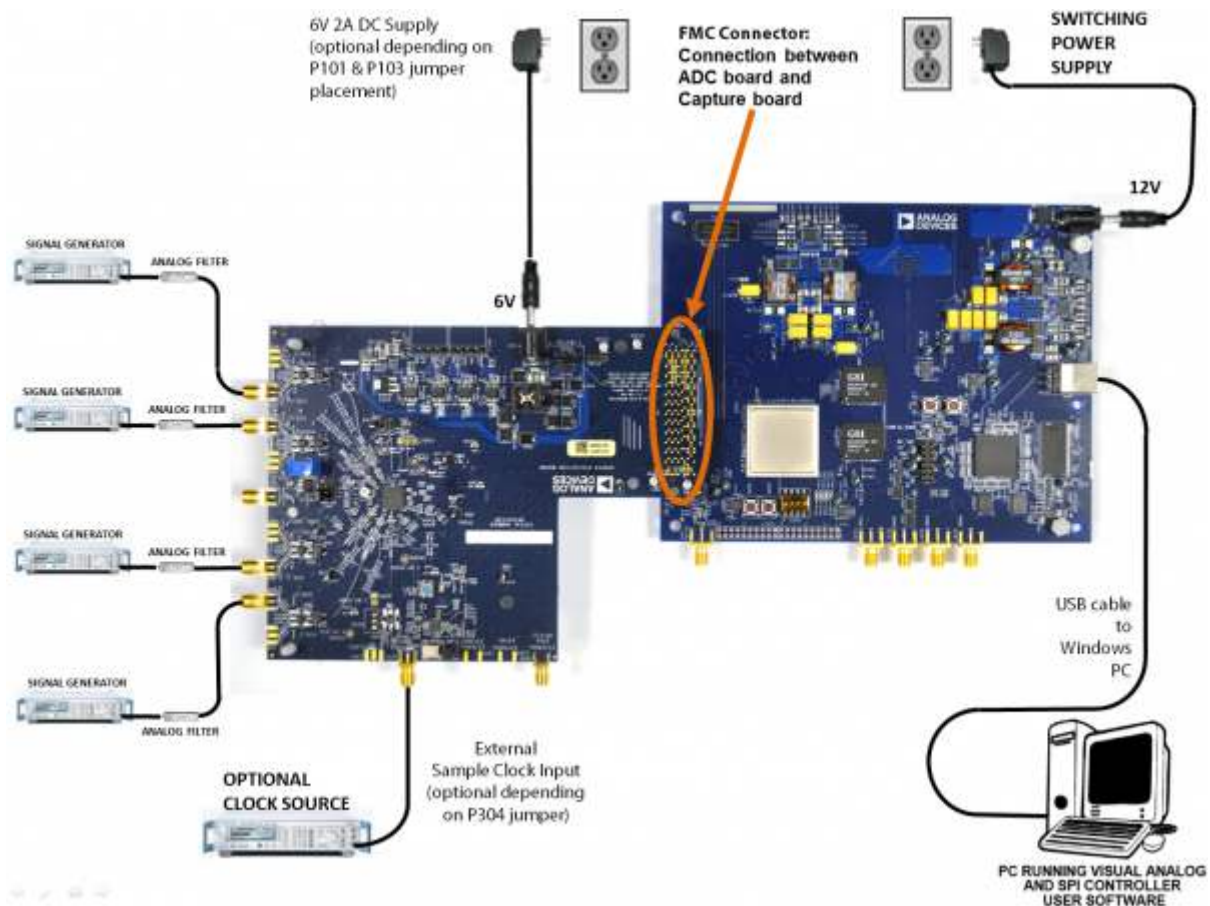

Figure 1. Evaluation Board Connection—[AD9656EBZ](#) (on Left) and [HSC-ADC-EVALEZ](#) (on Right)

## Features

- SPI interface for setup and control
- External, on-board oscillator
- On-board LDO regulator, needing a single external 6V, 2A dc supply
- ADC VREF configurable for ADC-internal reference, on-board reference, off-board reference
- VisualAnalog® and SPIController software interfaces

## Helpful Documents

- [AD9656](#) data sheet
- High speed ADC FIFO evaluation kit ([HSC-ADC-EVALEZ](#))
- HSC-ADC-EVALEZ Wiki Guide <http://wiki.analog.com/resources/eval/hsc-adc-eval>
- [AN-905 Application Note](#), *VisualAnalog Converter Evaluation Tool Version 1.0 User Manual*
- [AN-878 Application Note](#), *High Speed ADC SPI Control Software*
- [AN-877 Application Note](#), *Interfacing to High Speed ADCs via SPI*
- [AN-835 Application Note](#), *Understanding ADC Testing and Evaluation*

## Design and Integration Files

- [Schematics, layout files, bill of materials](#) <Coming Soon>

## Equipment Needed

- Analog signal source(s) and antialiasing filter(s)
- Sample clock source (if not using the on-board crystal oscillator)
- Switching power supply (6.0V, 2.5A) for AD9656EBZ
- Switching power supply (12V, 3.3A) for HSC-ADC-EVALEZ
- PC running Windows®
- USB 2.0 port
- [AD9656EBZ](#) board
- [HSC-ADC-EVALEZ](#) FPGA-based data capture kit

## Getting Started

This section provides quick start procedures for using the [AD9656EBZ](#) board. Both the default and optional ADC settings are described.

## Configuring the Board

Before using the software for testing, configure the evaluation board as follows:

1. Connect the evaluation board to the data capture board, as shown in Figure 1.
2. On the ADC evaluation board, confirm that the jumpers are installed as shown in Figure 2.
3. The [AD9656EBZ](#) can be powered in one of three ways. The default is to have the [AD9656EBZ](#) obtain its power from the [HSC-ADC-EVALEZ](#) through the FMC connector. For this configuration, jumper pin 1 to pin 2 on both P101 and P103 on the [AD9656EBZ](#). The other power configurations will be described in the Power Supplies section below.
4. Connect the 12V, 3.3A switching power supply to the [HSC-ADC-EVALEZ](#) board.
5. Connect the [HSC-ADC-EVALEZ](#) board (P702) to the PC using a USB cable.
6. On the ADC evaluation board, use a clean signal generator with low phase noise to provide an input signal to the desired channel(s). Use a shielded, RG-58, 50Ω coaxial cable (optimally 1 m or shorter) to connect the signal generator. For best results, use a narrow-band, band-pass filter with 50Ω terminations and an appropriate center frequency. (Analog Devices, Inc. uses TTE, Allen Avionics, and K&L band-pass filters.)

## Evaluation Board Hardware

The evaluation board provides the support circuitry required to operate the [AD9656](#) in its various modes and configurations. Figure 1 shows the typical bench characterization setup used to evaluate AC performance. It is critical that the signal sources used for the analog input and clock have very low phase noise (ideally ~100 fs rms jitter) to realize the optimum performance of the signal chain. Proper filtering of the analog input signal to remove harmonics and lower the integrated or broadband noise at the input is necessary to achieve the specified noise performance.

See [AD9656 Design Support <Coming Soon>](#) for schematics and layout diagrams. These diagrams demonstrate the routing and grounding techniques that should be applied at the system level when designing application boards using these converters.

### Power Supplies

The [AD9656EBZ](#) can obtain its power from the [HSC-ADC-EVALEZ](#) through the FMC connector. P101 and P103 both need to have pin 1 tied to pin 2 for obtaining board power through the FMC connector from the HSC-ADC-EVALEZ capture board. If P101 and P103 have pin 1 jumpered to pin 2, do not connect the supplied 6V wall supply to the AD9656 evaluation board. When changing the configuration of P101 and P103, please remove both jumpers and then place them in their desired positions.

Alternatively, the [AD9656EBZ](#) can obtain its power from the wall-mountable 6V, 2A switching power supply. For this mode, P101 and P103 both need to have pin 2 tied to pin 3. Connect the supply to a 100V ac to 240V ac, 47Hz to 63Hz wall outlet. The output from the supply is provided through a 2.1mm inner diameter jack that connects to the printed circuit board (PCB) at P102. The 6V supply is fused and conditioned on the PCB before connecting to the low dropout linear regulators that supply the proper bias to each of the various sections on the board.

Also, the evaluation board can be powered in a nondefault condition using external bench power supplies. To do this, remove the E104, E105, E106, and E108 ferrite beads to disconnect the on-board LDOs from the power planes. Note that in some board configurations some of these might already be uninstalled. P104 and P105 headers can be installed to facilitate connection of external bench supplies to the board. E110, E111, E112 and E113 need to be populated to connect P104 and P105 to the board power domains. A 1.8V, 0.5A supply is needed for 1.8V\_DUT\_AVDD, 1.8V\_DRVDD and 1.8V\_DVDD. Although the voltage requirements are the same for these three, it is recommended that separate supplies be used for each of these.

A 3.3V, 0.5A supply is needed for 3.3V\_DIG, which is used to power additional on board circuitry.

### Input Signals

The four channel inputs on the evaluation board are set up for a double balun-coupled analog input

with a 50Ω impedance. When connecting the ADC clock and analog source, use clean signal generators with low phase noise, such as the Rohde & Schwarz SMA, or an equivalent. Use a shielded, RG-58, 50Ω coaxial cable (optimally 1 m or shorter) for connecting to the evaluation board. Enter the desired frequency and amplitude (see the Specifications section in the data sheet). When connecting the analog input source, use of a multipole, narrow-band band-pass filter with 50Ω terminations is recommended. Analog Devices uses band-pass filters from TTE and K&L Microwave, Inc. Connect the filters as close to the evaluation board as possible.

## Clock

The default clock input circuit is derived from an on-board 125MHz crystal oscillator feeding through a transformer-coupled circuit using a high bandwidth 1:1 impedance ratio transformer (T302) that adds negligible jitter to the clock path. The external clock input (J302) is 50 Ω terminated and ac-coupled to handle single-ended sinusoidal inputs. The transformer converts the single-ended input to a differential signal that is clipped by CR301 before entering the ADC clock inputs. The [AD9656](#) ADC is equipped with an internal clock divider (programmable divide ratios of 1 through 8) to facilitate usage with higher frequency clocks. When using the internal divider and a higher input clock frequency, remove CR301 to preserve the slew rate of the clock signal.

The [AD9656EBZ](#) board is set up to be clocked through the transformer-coupled input network from the 125MHz crystal oscillator, Y801. If an external clock source is desired, remove C302 (optionally) and Jumper J304 to disable the oscillator from running and connect the external clock source to the SMA connector, J302 (labeled CLOCK+).

If an external clock source is used instead of the onboard crystal oscillator, it should also be supplied with a clean signal generator as previously specified for the analog input signals. Analog Devices evaluation boards typically can accept ~2.8V p-p or 13 dBm sine wave input for the clock at the board SMA clock connector.

## Output Signals

The default setup uses the Analog Devices high speed converter evaluation platform ( [HSC-ADC-EVALEZ](#)) for data capture. The JESD204B outputs from the ADC are routed to P2 using 100Ω differential traces. For more information on the data capture board and its optional settings, visit [www.analog.com/hsadcevalboard](http://www.analog.com/hsadcevalboard).

## Jumper Settings

Set the jumper settings/link options on the evaluation board for the required operating modes before powering on the board. The functions of the jumpers are described in Table 1. Figure 2 shows the default jumper settings.

## Table 1. Jumper Settings

Jumper	Description
P101, P103	<p>These jumpers determine the power source for the <a href="#">AD9656EBZ</a>. Connect Pin 1 to Pin 2 on both P101 and P103 to power the ADC board from the <a href="#">HSC-ADC-EVALEZ</a> through the FMC connector. Connect Pin 2 to Pin 3 on both P101 and P103 to power the ADC board from the wall supply connected to P102. Leave both P101 and P103 unjumped if using headers P104 and P105.</p>
J304	<p>This jumper enables the on-board crystal oscillator. Remove this jumper (and optimally C302) if an external off-board clock source is used.</p>
J206	<p>This jumper selects between internal <math>V_{REF}</math> and external <math>V_{REF}</math>. To choose the ADC's internal reference, connect Pin 3 (DUT_SENSE) to Pin 5 (GND) as shown in Figure 2. The default value of the internal reference is 1 V. SPI Register 0x18 Bits[7:6] can be used to program the internal reference voltage to values from 1 V to 1.4 V, in 0.1 V increments. Register control is accomplished with SPIController software, which is discussed below in the <b>Setting up the SPI Controller Software</b> section.</p> <p>To use the on-board <a href="#">AD822</a> buffered reference, connect Pin 2 (DUT_SENSE) to Pin 1 (AVDD), and connect Pin 4 (DUT_VREF) to Pin 6 (EXT_REF). Adjust external VREF to the desired value (from 1.0 V to 1.4 V) using potentiometer R247.</p> <p>To apply a reference voltage from an external off-board source, connect Pin 2 (DUT_SENSE) to Pin 1 (AVDD) and apply the reference voltage to Pin 4 (DUT_VREF). The AD9656 reference voltage is specified to be from 1.0 V to 1.4 V.</p>

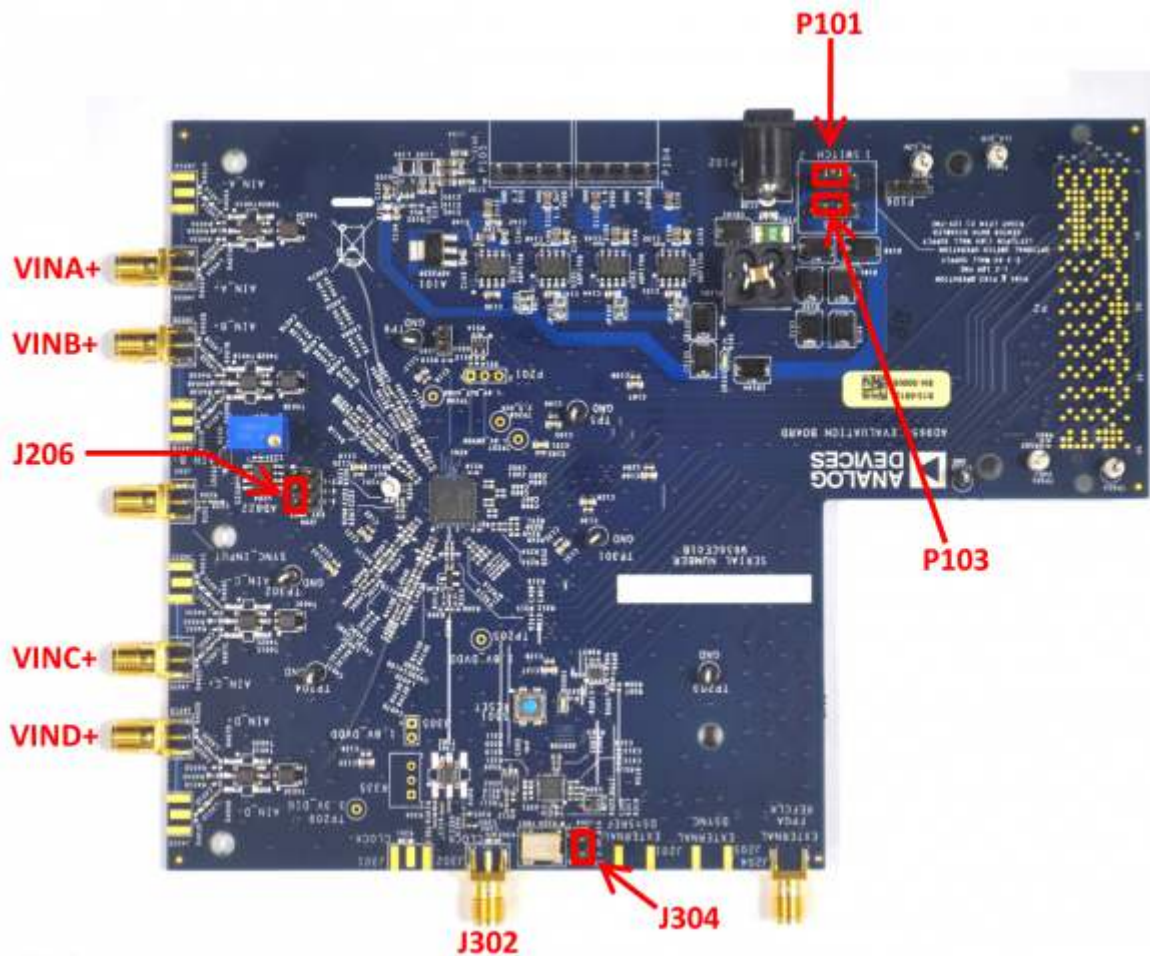

Figure 2. Default Jumper Connections for *AD9656EBZ* Board

## How To Use The Software For Testing

### Setting up the ADC Data Capture

The installers for VisualAnalog and SPIController are in the following locations:

[ftp://ftp.analog.com/pub/HSSP\\_SW/VisualAnalog/VisualAnalog\\_Setup.exe](ftp://ftp.analog.com/pub/HSSP_SW/VisualAnalog/VisualAnalog_Setup.exe)

[ftp://ftp.analog.com/pub/adispi/A2DComponents/Install/SPIController\\_Setup.exe](ftp://ftp.analog.com/pub/adispi/A2DComponents/Install/SPIController_Setup.exe)

Run these installers on the PC that is connected to the evaluation setup before proceeding.

After configuring the board hardware, set up the ADC data capture using the following steps:

1. Start VisualAnalog on the connected PC. The appropriate part type should be listed in the status bar of the **VisualAnalog - New Canvas** window. Select the template that corresponds to the type of testing to be performed (see Figure 3). Average FFT is a good test to start with.

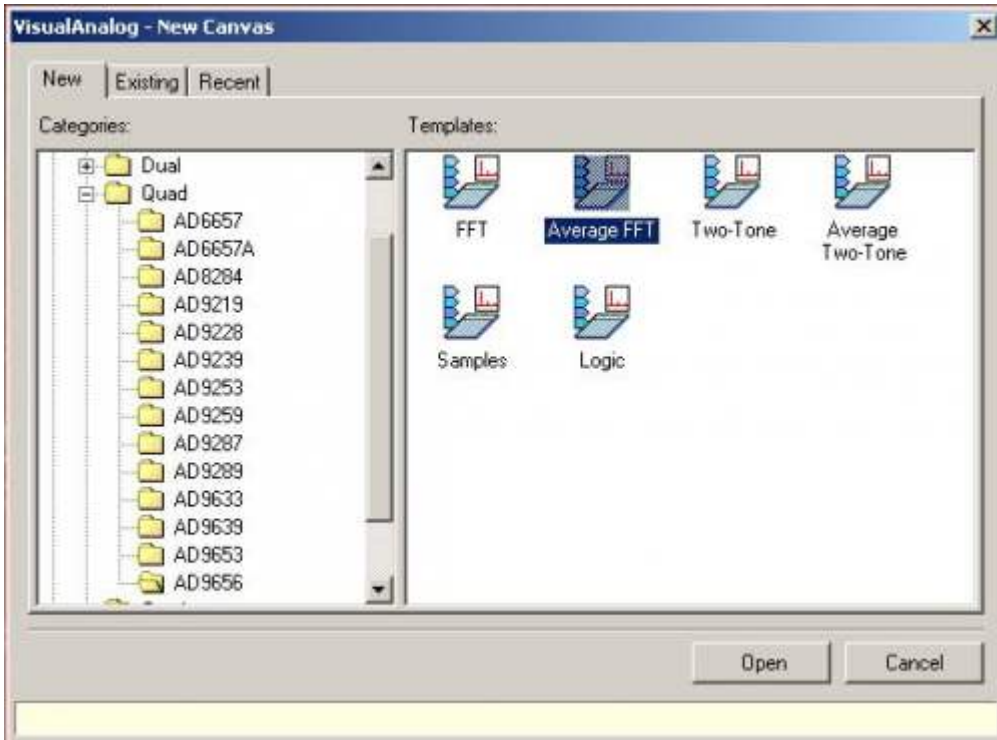

Figure 3. VisualAnalog, New Canvas Window

- After the template is selected, a message might appear asking if the default configuration can be used to program the FPGA (see Figure 4). If this message appears, click **Yes**, and the window will close.

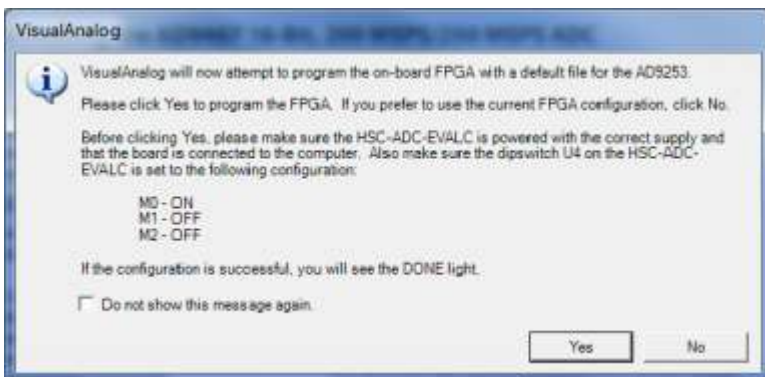

Figure 4. VisualAnalog Default Configuration Message

- To view the canvas and associated functional blocks, click the **Expand Display** button, located on the bottom right corner of the window (see Figure 5), to see what is shown in Figure 6.



Figure 5. VisualAnalog Window Toolbar, Collapsed Display



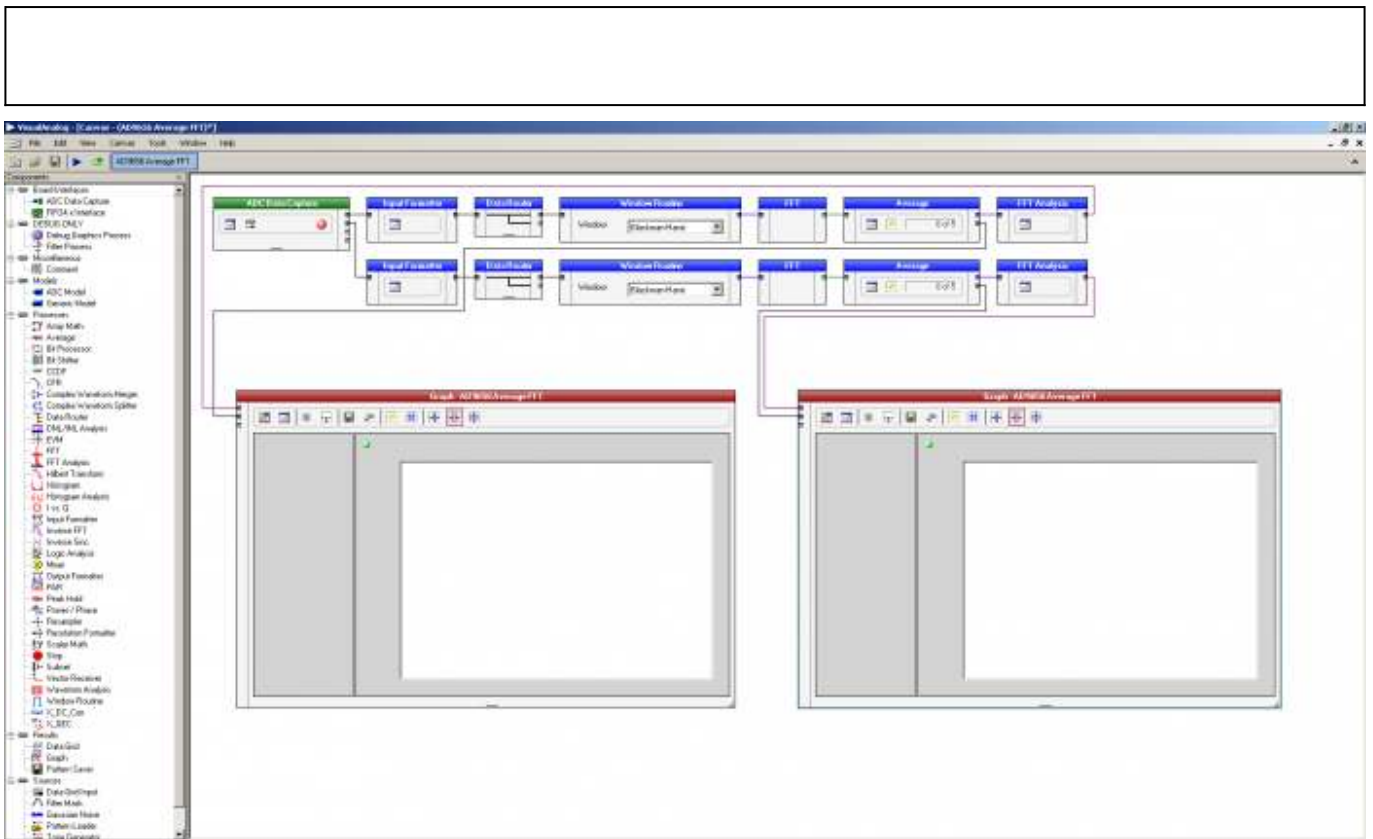

Figure 6. VisualAnalog, Main Window Expanded Display

4. To configure VisualAnalog to operate with the AD9656, push the Settings button on the ADCDataCapture block, as shown in Figure 7.



Figure 7. VisualAnalog Window Toolbar, Collapsed Display

5. In the ADC Data Capture Settings Window, General Tab, select AD9656 to be the device, enter the sample clock frequency (125 is the default value), as shown in Figure 8. The sample frequency entered here is used for scaling of frequency values in test results and graphs. In the Output Data field, the channels to be tested are selected, as well as the FFT capture depth (“Length”). Note that the total of the capture depths for all selected channels cannot exceed 256k.

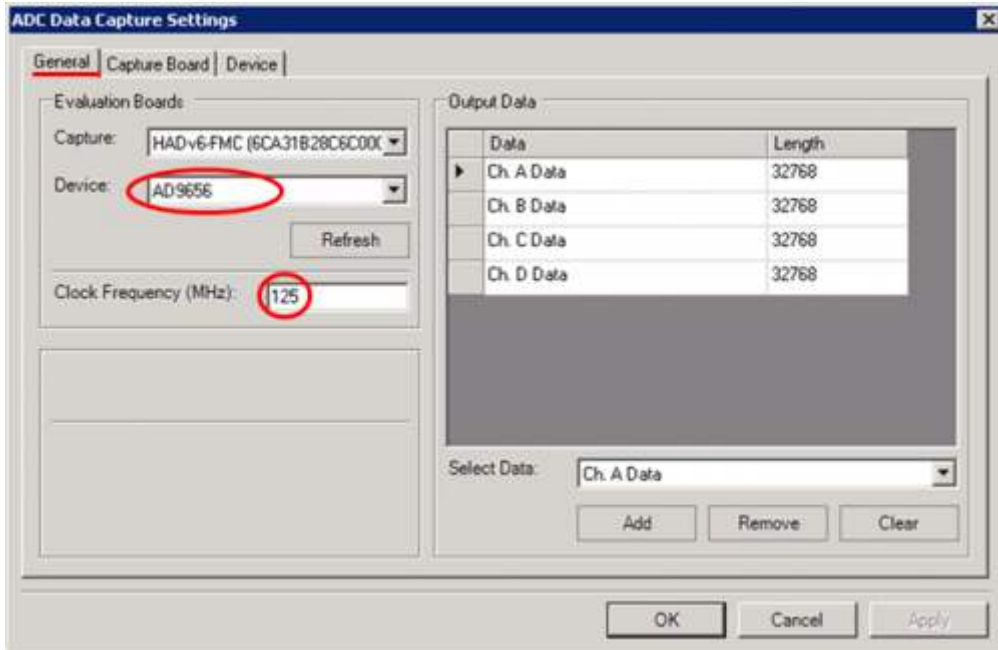

Figure 8. VisualAnalog ADC Data Capture Settings Window, General Tab

6. In the ADC Data Capture Settings Window, Capture Board Tab, enter 60 in the Fill Delay field. Push the Browse button to navigate to the FPGA program file for the AD9656. The default installation location and filename will be similar to: C:\Program Files\Analog Devices\VisualAnalog\Hardware\HADv6\AD9656\_hadv6fmc.mcs Push the program button.

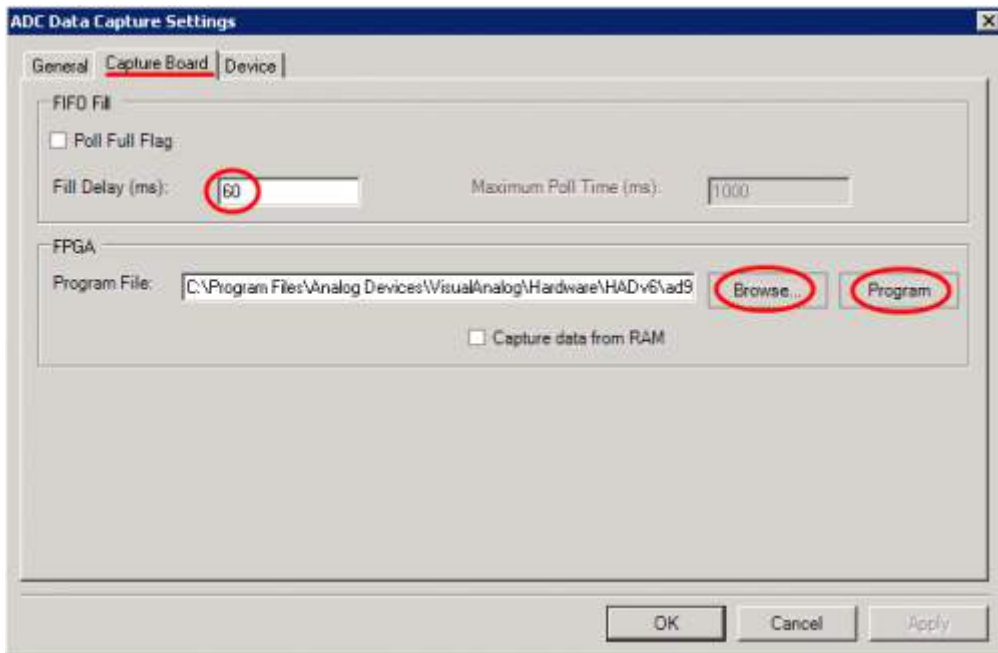

Figure 9. VisualAnalog ADC Data Capture Settings Window, Capture Board Tab

7. In the ADC Data Capture Settings Window, Device Tab, check the Enable Data Capture Controls

checkbox. The capture control fields will be enabled.  
Select:

- GTX RX Equalization: 6
- Encode: 125MSPS (default configuration)
- Number of lanes: 2 Lanes (At least 2 lanes are required for 125MSPS. The single lane bitrate at 125MSPS would exceed the driver and FPGA capabilities.)
- Leave the other checkboxes unchecked.

Though the AD9656 supports a wide variety of converter/lane/sample rate configurations, the software supports only the configurations in the software menu as an out-of-the-box functional kit. If other sample rates or configurations are required, an additional external clock is likely needed.

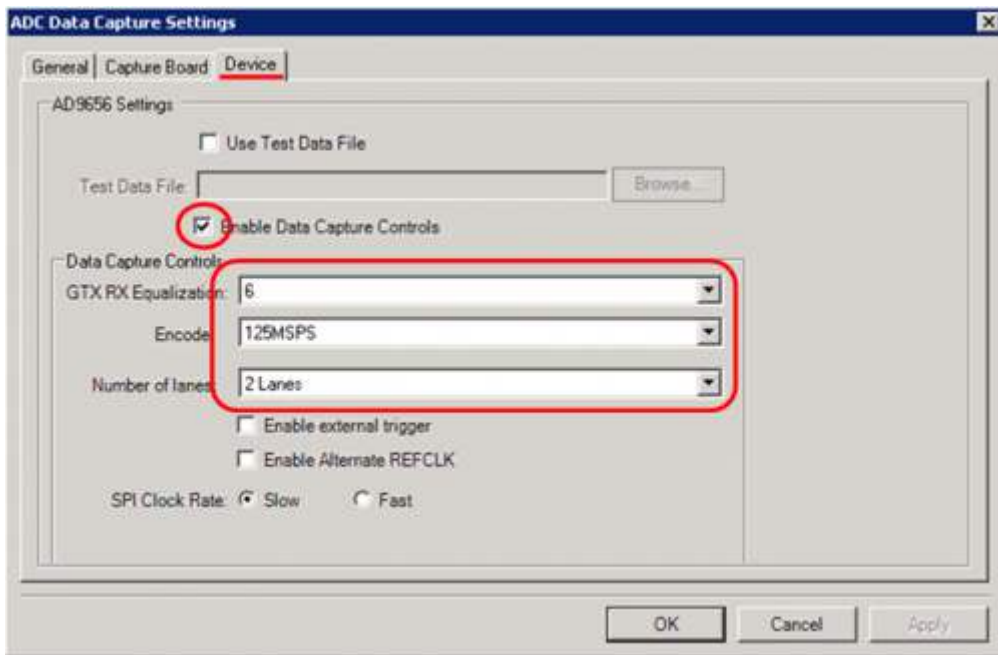

Figure 10. VisualAnalog ADC Data Capture Settings Window, Device Tab

8. VisualAnalog is now setup to work with the AD9656EBZ in the default configuration. Other VisualAnalog features and capture settings are documented in the [AN-905 Application Note](#), *VisualAnalog Converter Evaluation Tool Version 1.0 User Manual*.

## Evaluation And Test

### Setting up the SPI Controller Software

After the ADC data capture board setup is complete, set up the SPI controller software using the following procedure:

1. Open the SPI controller software by going to the **Start** menu or by double-clicking the

**SPIController** software desktop icon. If prompted for a configuration file, select .cfg file whose name begins with AD9656. If not prompted, check the title bar of the window to determine which configuration is loaded. If necessary, choose **Cfg Open** from the **File** menu and select the appropriate file based on your part type. Note that the **CHIP ID(1)** box should be filled to indicate whether the correct SPI controller configuration file is loaded (see Figure 11).

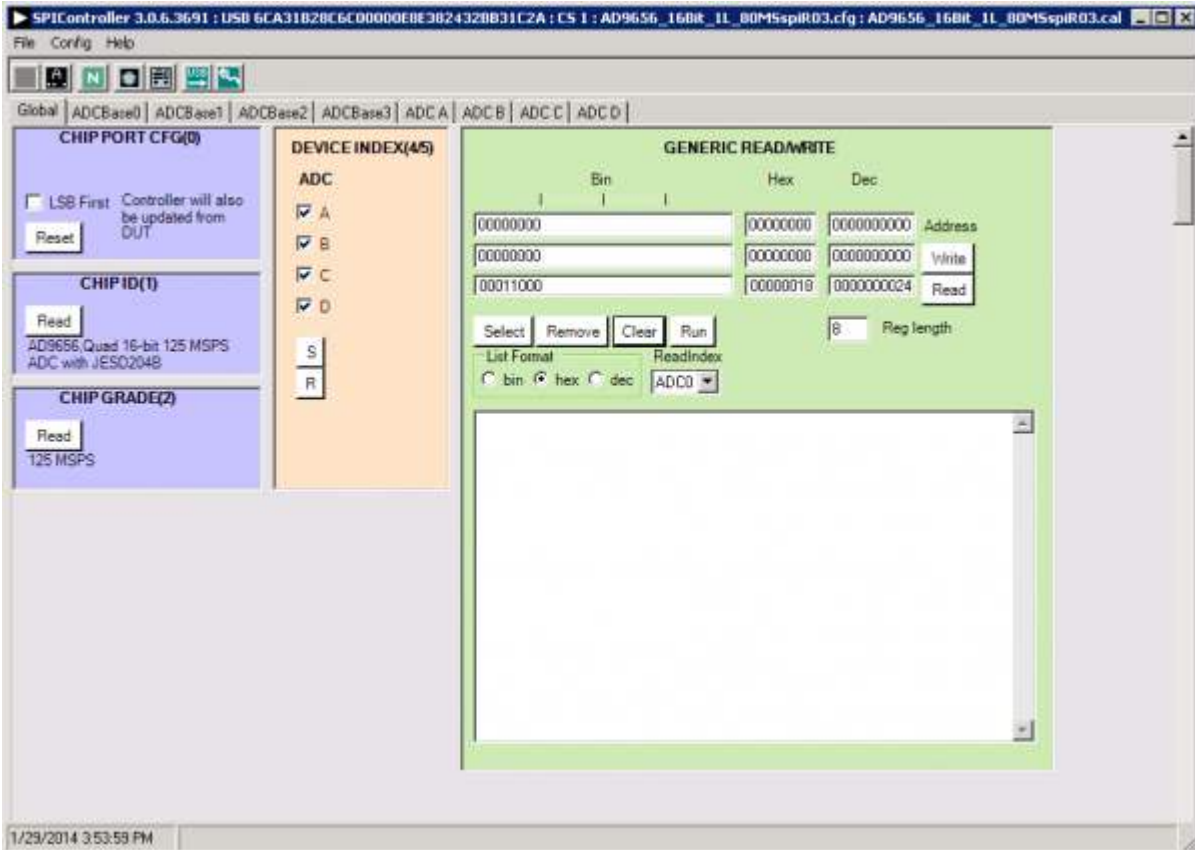

Figure

11. SPI Controller, CHIP ID(1) Box
2. Click the **New DUT** button in the **SPIController** window (see Figure 12)

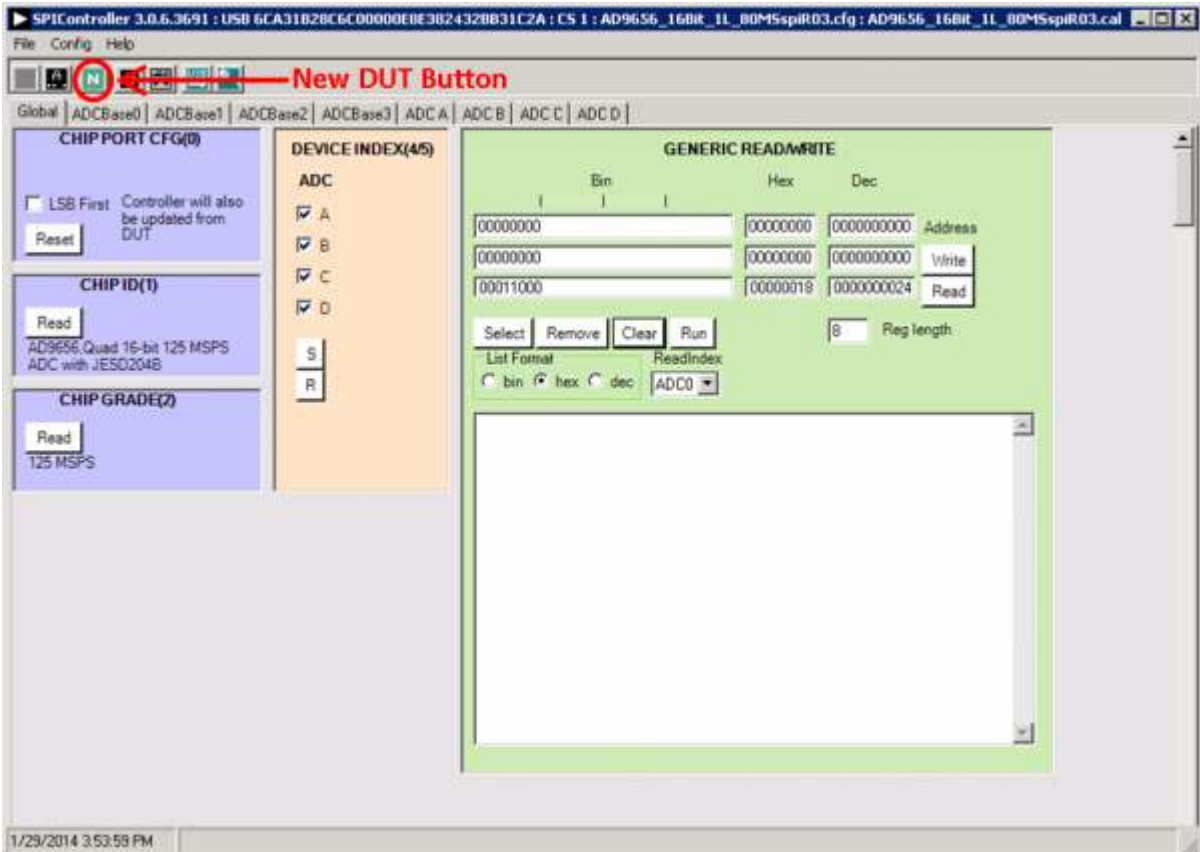

Figure

12. SPI Controller, New DUT Button

- In the **ADCBase0** tab of the **SPIController** window, find the **CLOCK DIVIDE(B)** box (see Figure 13), and the **MODES(8)** box (see Figure 14). If using the clock divider, use the drop-down box to select the correct clock divide ratio, if necessary. If there is any interruption of the ADC clock during power-up or during operation, a Digital Reset may be needed to re-initialize the ADC (Figure 14). For additional information, refer to the data sheet, the [AN-878 Application Note, High Speed ADC SPI Control Software](#), and the [AN-877 Application Note, Interfacing to High Speed ADCs via SPI](#).

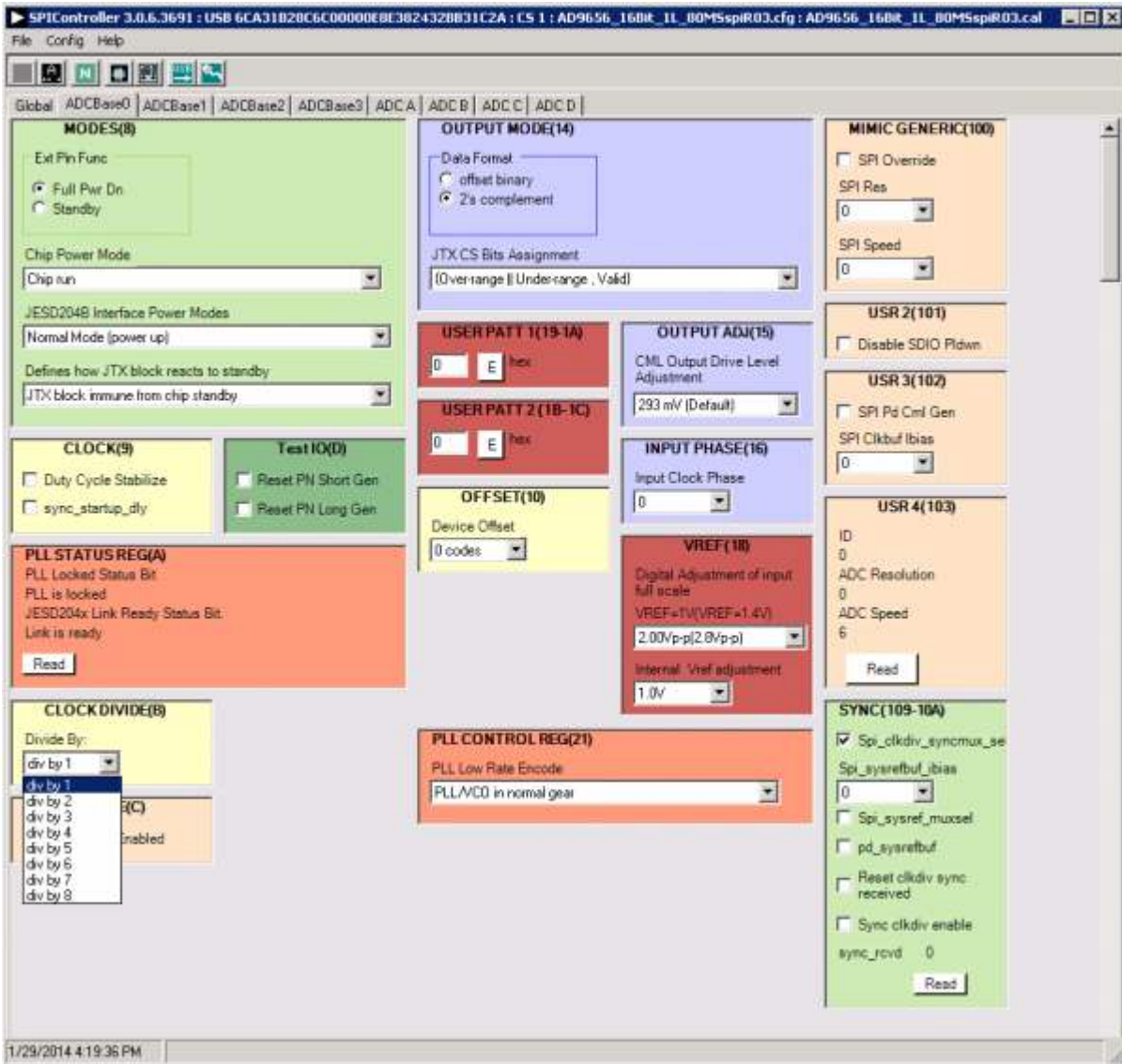

Figure

13. SPI Controller, CLOCK DIVIDE(B) Box

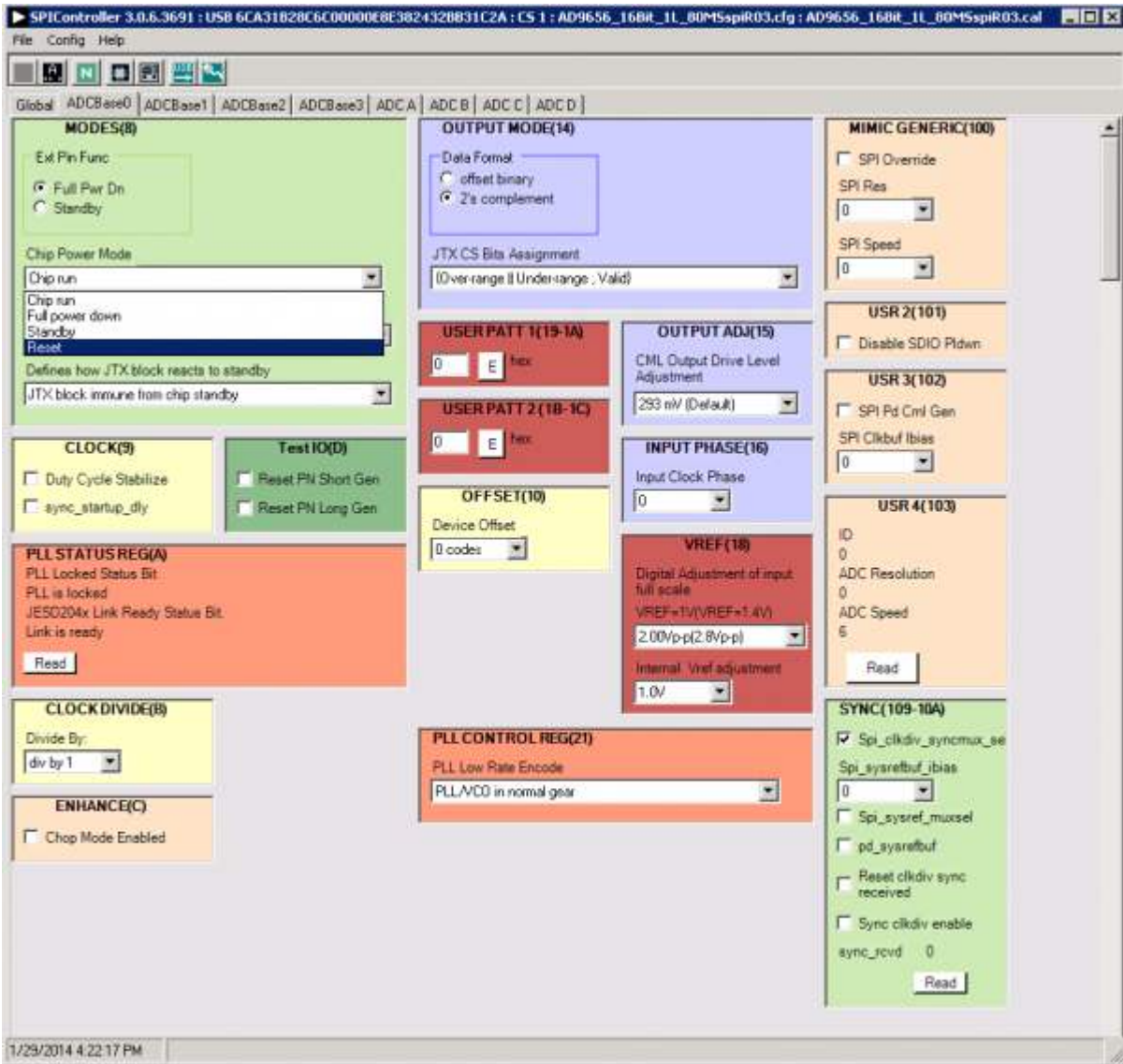

Figure 14. SPI Controller, Chip Power Mode - Digital Reset Selection

- In the **ADCBase1** tab of the **SPIController** window, set the number of lanes the AD9656 will be configured to. Note that the number of lanes selected here must match the settings made in VisualAnalog as shown in Step 7, Figure 10 above.

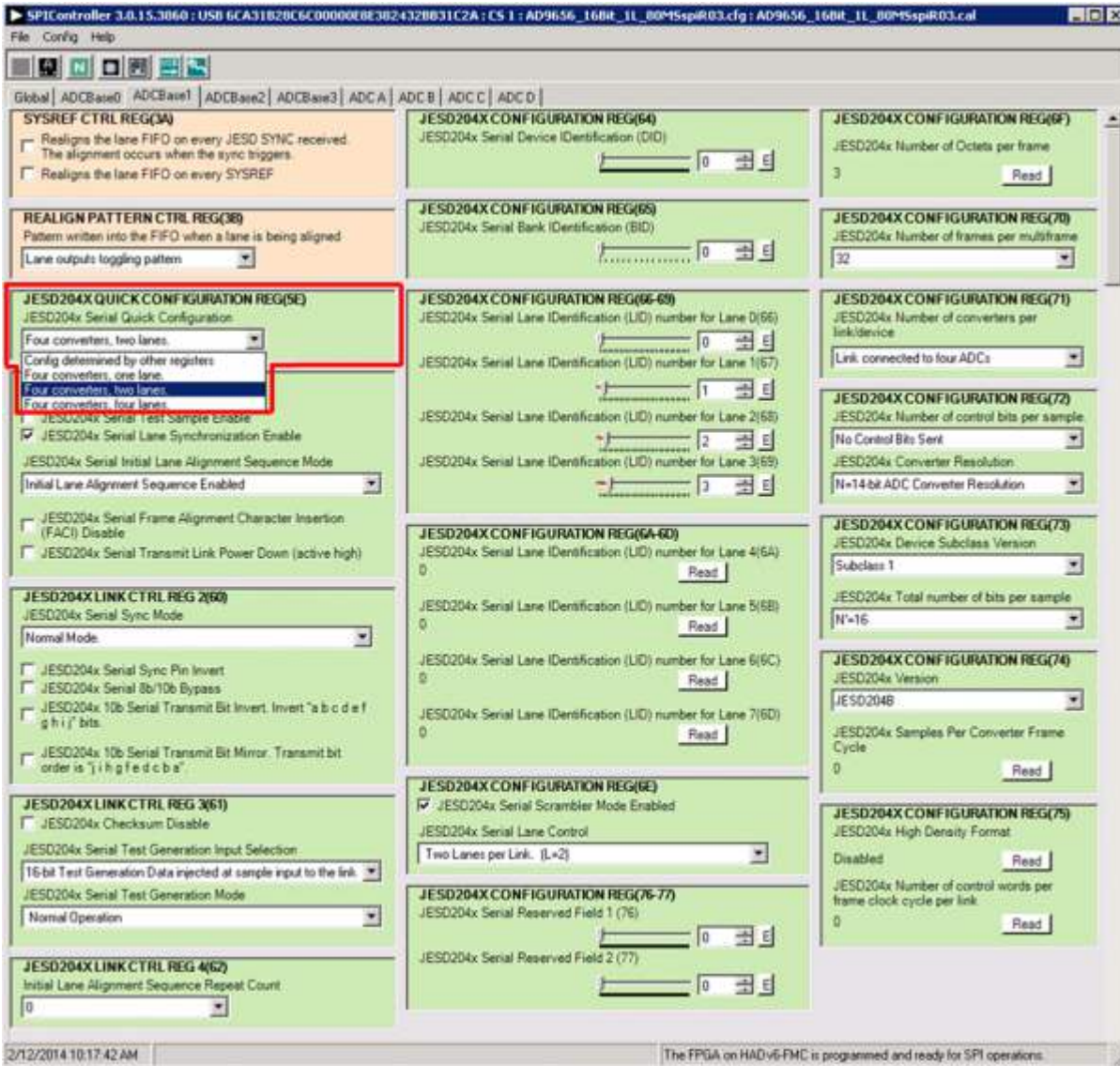

Figure 15. SPI Controller, Quick Configure Box

- Note that other settings can be changed on the **ADCBase0** tab (see Figure 13) and the **ADC A** through **ADC D** tabs (see Figure 16) to set up the part in the desired mode. The **ADCBase0** tab settings affect the entire part, whereas the settings on the **ADC A** through **ADC D** tabs each affect the selected channel only. See the data sheet, the [AN-878 Application Note, High Speed ADC SPI Control Software](#), and the [AN-877 Application Note, Interfacing to High Speed ADCs via SPI](#), for additional information on the available settings.



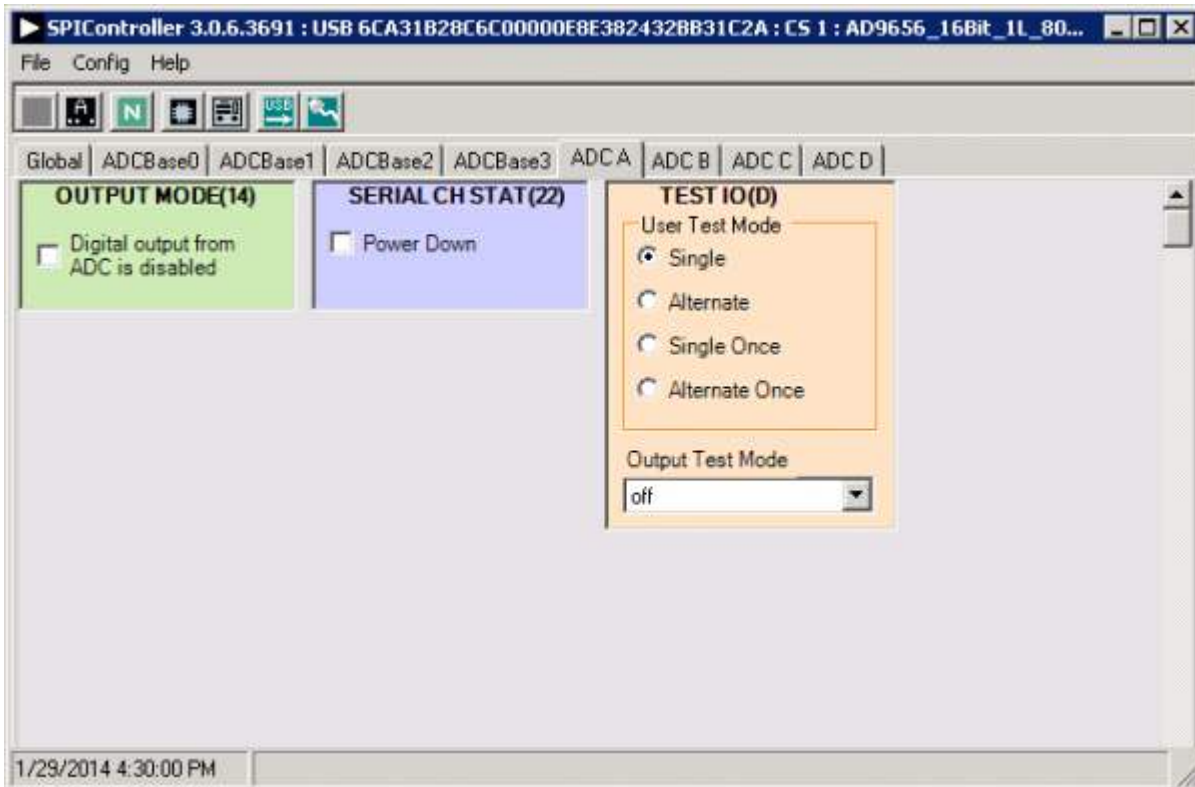

Figure 16. SPI Controller, Example ADC A Page

6. Invoke a Digital Reset as shown in Figure 14 before testing. After selecting Reset, select Chip run to return to normal operation.
7. To begin testing, click the **Run** or **Continuous Run** button in the **VisualAnalog** toolbar (see Figure 17).

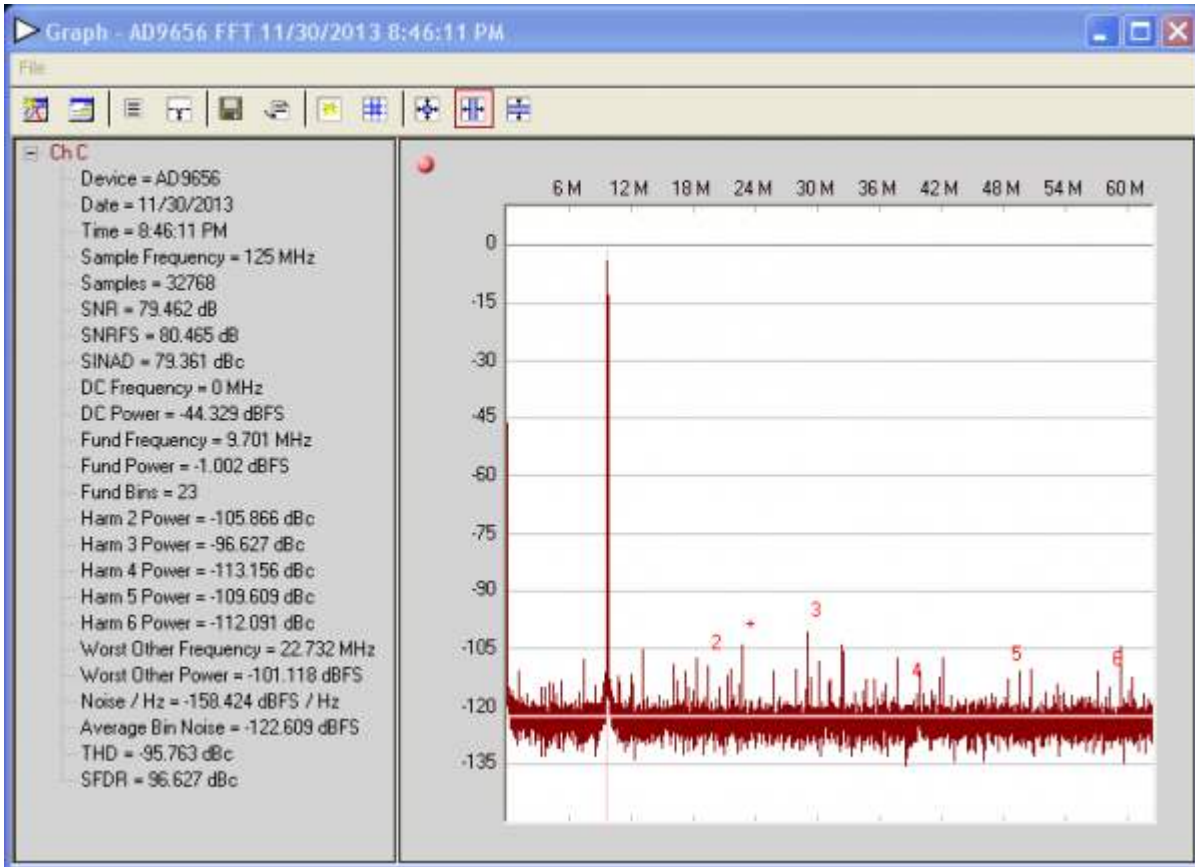

Figure 17. Run/Continuous Run Buttons (Encircled in Red) in VisualAnalog Toolbar, Collapsed Display

## Adjusting the Amplitude of the Input Signal

The next step is to adjust the amplitude of the input signal for each channel as follows:

1. Adjust the amplitude of the input signal so that the fundamental is at the desired level. Examine the **Fund Power** reading in the left panel of the **VisualAnalog Graph - AD9656 FFT** window (see Figure 18).



Figure

### 18. Graph Window of VisualAnalog

2. Repeat this procedure for the other channels, if desired
3. Click the floppy-disk icon within the **VisualAnalog Graph - AD9656 FFT** window to save the performance data as a .csv formatted file for plotting or analysis.

## Troubleshooting Tips

Lack of SPI communication will cause difficulty in configuring the ADC.

- Go to the **Global** tab of the **SPIController** window and push the **Read** button in the **GENERIC READ/WRITE** window. This will read the contents of ADC register 0x00. If SPI communication is working properly and the ADC is powered up, the value 0x18 hexadecimal will appear. If the contents show 0x00, the ADC is not powered up or SPI communication is not working.
- Check that there is correct power to the [AD9656EBZ](#) board, and to the [HSC-ADC-EVALEZ](#).
- Check that the USB cable is properly connected from the PC to the [HSC-ADC-EVALEZ](#).
- The LED on the **VisualAnalog ADCDataCapture** block should be green. If it is red, push the USB button on the same block to refresh the connection.

If the FFT plot appears abnormal, do the following:

- If you see an abnormal noise floor, go to the **ADCBase0** tab of the **SPIController** window and toggle the **Chip Power Mode** in **MODES(8)** from **Chip Run** to **Reset** and back (Figure 14).
- If you see a normal noise floor when you disconnect the signal generator from the analog input, be sure that you are not overdriving the ADC. Reduce the input level, if necessary.
- In **VisualAnalog**, click the **Settings** icon in the **Input Formatter** block. Check that **Number**

**Format** is set to the correct encoding (twos complement by default). Check that the **Number Format** in the **VisualAnalog Input Formatter** matches the data format selected in the **SPIController ADCBase0 OUTPUT MODE(14)** window. Repeat for the other channels.

If the FFT appears normal but the performance is poor, check the following:

- Make sure that an appropriate filter is used on the analog input.
- Make sure that the signal generators for the clock and the analog input are clean (low phase noise).
- Change the analog input frequency slightly if noncoherent sampling is being used.
- Make sure that the SPI configuration file matches the product being evaluated.

If the FFT window remains blank after **Run** in VisualAnalog (see Figure 17) is clicked, do the following:

- Make sure that the evaluation board is securely connected to the [HSC-ADC-EVALEZ](#) board.
- Make sure that the correct FPGA program was installed by clicking the **Settings** icon in the **ADC Data Capture** block in VisualAnalog. Then select the **FPGA** tab and verify that the proper FPGA .mcs file (one containing “AD9656” in the filename) is selected for the part.
- Make sure that the FPGA has been programmed by verifying that the **CONFIG\_DONE** LED is illuminated on the [HSC-ADC-EVALEZ](#) board. If the **CONFIG\_DONE** LED is not illuminated, click the **Settings** icon in the **ADC Data Capture** block in VisualAnalog. Then select the **FPGA** tab and verify that the proper FPGA .mcs file (one containing “AD9656” in the filename) is selected for the part. Then push the **Program** button. The LED should light up.
- On the [AD9656EBZ](#) there is an LED next to a reset button (S501). If this LED is not lit, push the reset button and try running again.

© Analog Devices, Inc. All rights reserved. Trademarks and registered trademarks are the property of their respective owners.



[www.analog.com](http://www.analog.com)