

- 1. TYPE RCX510N25
- 2. STRUCTURE SILICON N-CHANNEL MOS FET
- 3. APPLICATIONS SWITCHING



4. ABSOLUTE MAXIMUM RATINGS [Ta=25°C]

DRAIN-SOURCE VOLTAGE		$V_{DSS}$	• • •	250V
GATE-SOURCE VOLTAGE		$V_{GSS}$	• • •	±30V
DRAIN CURRENT	CONTINUOUS	$I_D$	• • •	±51A*
	PULSED	$I_{DP}$	• • •	±204A* PW ≤ 10 μs DUTY CYCLE ≤ 1%
SOURCE CURRENT	CONTINUOUS	$I_S$	• • •	51A*
(BODY DIODE)	PULSED	$I_{SP}$	• • •	204A* PW ≤ 10 μs DUTY CYCLE ≤ 1%
TOTAL POWER DISSIPATION		$P_D$	• • •	40W (Tc=25°C)
CHANNEL TEMPERATURE		$T_{ch}$	• • •	150°C
RANGE OF STORAGE TEMPERATURE		$T_{stg}$	• • •	-55~150°C

5. THERMAL RESISTANCE

CHANNEL TO CASE	$R_{th(ch-c)}$	• • •	3.13°C/W
-----------------	----------------	-------	----------

\* Limited only by maximum channel temperature allowed

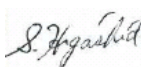
DESIGN	CHECK	APPROVAL	DATE : 26/DEC/2008	SPECIFICATION No.TSQ03050-RCX510N25
			REV. : 0	<b>ROHM CO., LTD.</b>

6.ELECTRICAL CHARACTERISTICS [Ta=25°C]  
《MOSFET.》

PARAMETER	ITEM	CONDITION	MIN.	TYP.	MAX.
GATE-SOURCE LEAKAGE	$I_{GSS}$	$V_{GS} \pm 30V / V_{DS} = 0V$	—	—	$\pm 100nA$
DRAIN-SOURCE BREAKDOWN VOLTAGE	$V_{(BR)DSS}$	$I_D = 1mA / V_{GS} = 0V$	250V	—	—
ZERO GATE VOLTAGE DRAIN CURRENT	$I_{DSS}$	$V_{DS} = 250V / V_{GS} = 0V$	—	—	10 $\mu A$
GATE THRESHOLD VOLTAGE	$V_{GS(th)}$	$V_{DS} = 10V / I_D = 1mA$	3.0V	—	5.0V
STATIC DRAIN-SOURCE ON-STATE RESISTANCE	$R_{DS(on)}$ * PULSED	$I_D = 25.5A / V_{GS} = 10V$	—	48m $\Omega$	65m $\Omega$
FORWARD TRANSFER ADMITTANCE	$ Y_{fs} $ * PULSED	$V_{DS} = 10V / I_D = 25.5A$	15S	—	—
INPUT CAPACITANCE	$C_{iss}$	$V_{DS} = 25V$ $V_{GS} = 0V$ $f = 1MHz$	—	7000pF	—
OUTPUT CAPACITANCE	$C_{oss}$		—	350pF	—
REVERSE TRANSFER CAPACITANCE	$C_{rss}$		—	200pF	—
TURN-ON DELAY TIME	$t_{d(on)}$ * PULSED	$V_{DD} \doteq 125V$ $I_D = 25.5A$ $V_{GS} = 10V$ $R_L = 4.9\Omega$ $R_G = 10\Omega$ see Fig. 1-1,1-2	—	65ns	—
RISE TIME	$t_r$ * PULSED		—	300ns	—
TURN-OFF DELAY TIME	$t_{d(off)}$ * PULSED		—	170ns	—
FALL TIME	$t_f$ * PULSED		—	210ns	—
TOTAL GATE CHARGE	$Q_g$ * PULSED	$V_{DD} \doteq 125V$ $I_D = 51A$ $V_{GS} = 10V$ $R_L = 2.5\Omega / R_G = 10\Omega$ See Fig.2-1,2-2	—	120nC	—
GATE-SOURCE CHARGE	$Q_{gs}$ * PULSED		—	40nC	—
GATE-DRAIN CHARGE	$Q_{gd}$ * PULSED		—	40nC	—

## BODY DIODE (SOURCE-DRAIN)

PARAMETER	ITEM	CONDITION	MIN.	TYP.	MAX.
FORWARD VOLTAGE	$V_{SD}$ * PULSED	$I_S = 51A / V_{GS} = 0V$	—	—	1.5V

## 7.INNER CIRCUIT

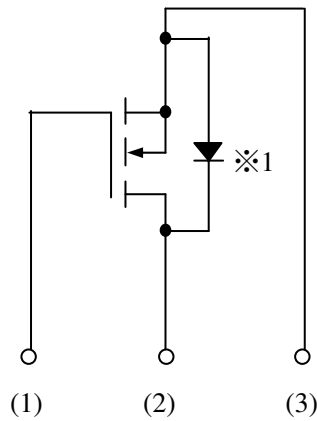

⊛ 1 BODY DIODE

- (1) GATE
- (2) DRAIN
- (3) SOURCE

## 8.MARKING

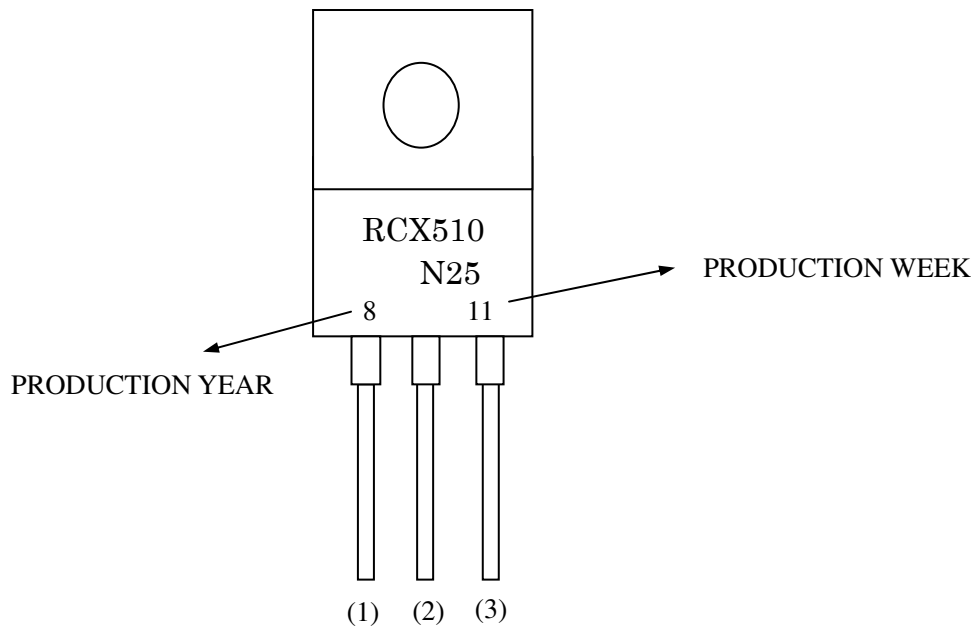

## 9.MEASUREMENT CIRCUIT

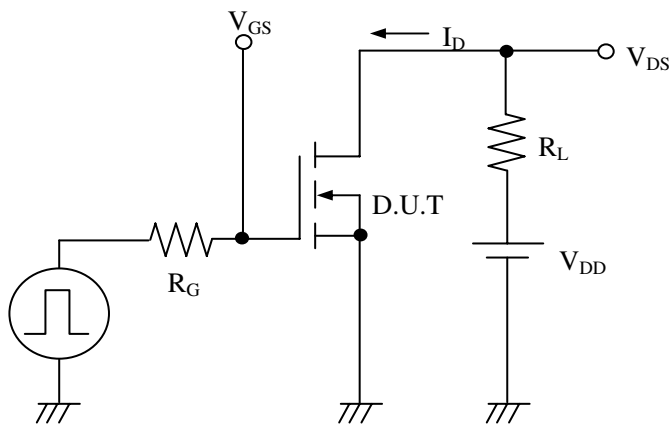

Fig.1-1 SWITCHING TIME MEASUREMENT CIRCUIT

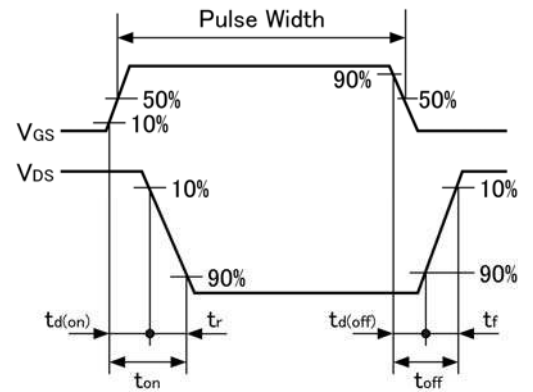

Fig.1-2 SWITCHING WAVEFORMS

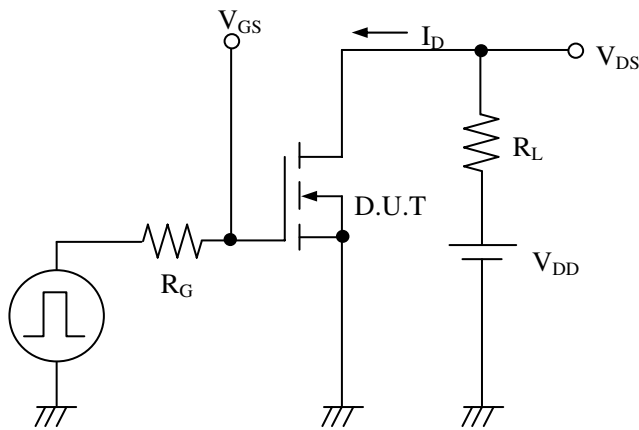

Fig.2-1 GATE CHARGE MEASUREMENT CIRCUIT

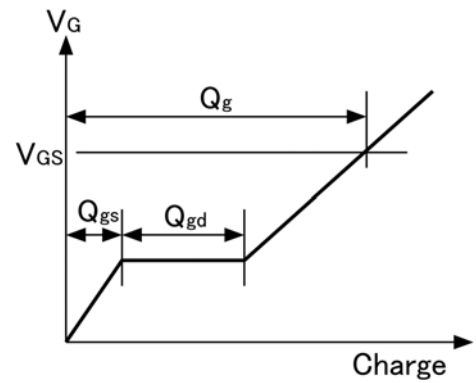

Fig.2-2 GATE CHARGE WAVEFORM