

THIS DRAWING IS UNPUBLISHED. RELEASED FOR PUBLICATION
 © COPYRIGHT BY TYCO ELECTRONICS CORPORATION. ALL RIGHTS RESERVED.

LOC	DIST	REVISIONS					
AG	53	P	LTR	DESCRIPTION	DATE	DWN	APVD
			A	REVISED PER ECO-06-001742	31JAN06	JDP	JGH

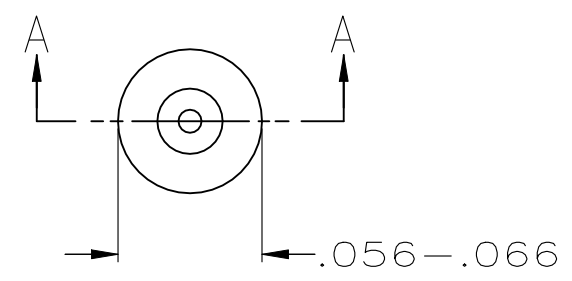

- MATERIAL:
 EYELET: COPPER PER ASTM B 152
 SPRING: BERYLLIUM COPPER PER ASTM B 194
- PLATING:
 EYELET: TIN PLATE PER ASTM B 545
 .000100 MIN THICK
 SPRING: GOLD PLATE PER ASTM B 488
 .000030 MIN THICK OVER NICKEL PLATE PER QQ-N-290 ON CONTACT AREA.
 TIN PLATE PER ASTM B 545
 .000150 MIN THICK

3 TO INSURE 1/2 OZ MIN RETENTION DO NOT EXCEED .004 DIFFERENCE IN PIN DIA WHEN CHANGING TO A SMALLER DIA PIN

4. HOLE SIZE FOR HAND INSERTION 0.043-0.046

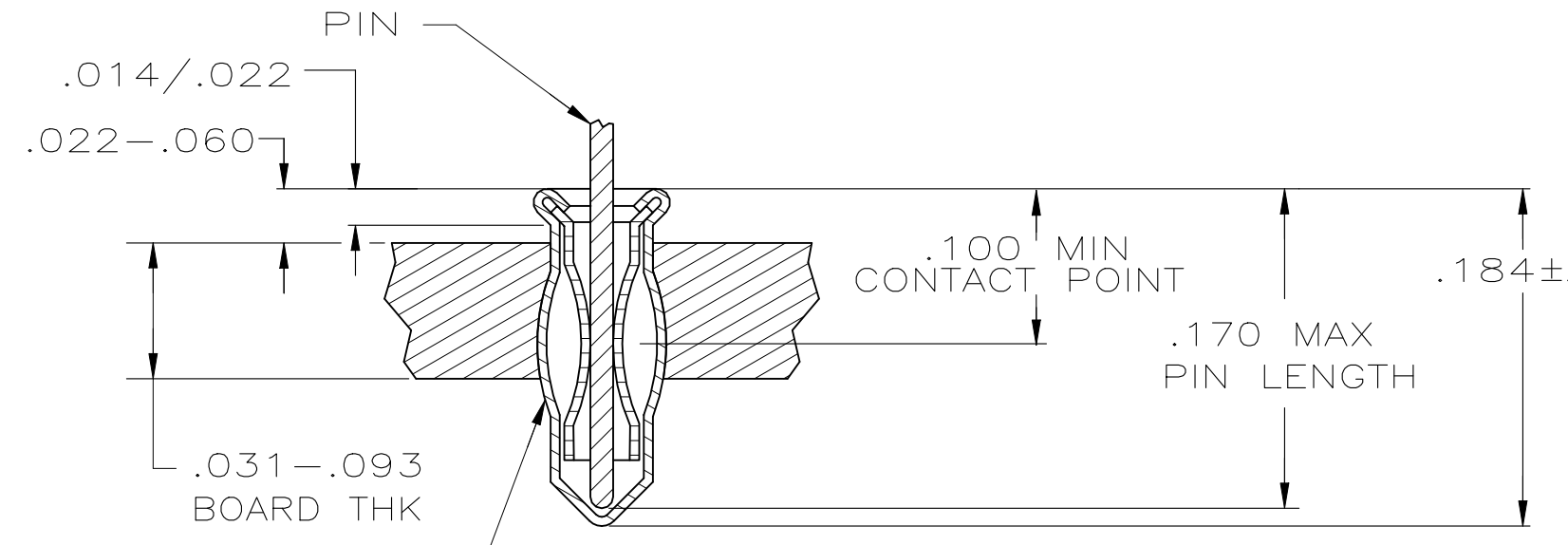

SECTION A-A

.100/.170	.012/.021	TIN	TIN	5645946-1
.100/.170	.012/.021	GOLD	TIN	5645946-2
LENGTH	DIA 3	SPRING	EYELET	PART NO
PIN		FINISH		
NO. 1 SERIES LONG				

THIS DRAWING IS A CONTROLLED DOCUMENT.		DWN G. ATTADIA - 20APR2005 DOCK5	Tyco Electronics Corporation Harrisburg, PA 17105-3608	
DIMENSIONS: INCHES		CHK J. HAVENER - 20APR2005	NAME MINIATURE SPRING SOCKET ASSEMBLY	
TOLERANCES UNLESS OTHERWISE SPECIFIED:		APVD J. HAVENER - 20APR2005	PRODUCT SPEC 108-14008	
0 PLC ± - 1 PLC ± - 2 PLC ± - 3 PLC ± - 4 PLC ± - ANGLES ± -		APPLICATION SPEC 114-13152	SIZE A3	CAGE CODE 00779
MATERIAL NOTE 1		WEIGHT -	DRAWING NO C-5645946	RESTRICTED TO -
FINISH NOTE 2		CUSTOMER DRAWING		SCALE NTS
		SHEET 1 OF 1		REV A