

REAL TIME CLOCK MODULE (I²C-Bus) High-Stability Frequency with Built in Timestamp and Power Switching **RX-8035SA / LC**



Product Number
RX-8035SA B : X1B000172000100
RX-8035SA AC : X1B000172000200
RX-8035SA AA : X1B000172000300
RX-8035LC B : X1B000182000100
RX-8035LC AC : X1B000182000200
RX-8035LC AA : X1B000182000300



RX-8035SA



RX-8035LC

- Built-in 32.768 kHz crystal unit : Frequency adjusted for high accuracy. ($\pm 5 \times 10^{-6} / T_a = +25^\circ\text{C}$)
- Interface Type : I²C-Bus Interface (400kHz)
- Operating voltage range : 2.4 V to 5.5 V
- Wide voltage for Timekeeping. : 1.0 V to 5.5 V
- Low backup current : 350 nA (SA) 400 nA (LC) / 3 V (Typ.)
- Event detection and Time stamp : One-shot full timestamp and interrupt.
- Dual event detection ports : Each terminal has a de-bounce circuit.
- Auto power switching functions : It switches VDD and VBAT, automatically.
- Dual Alarm, Periodic interruption.

Epson prepared Linux driver for development.

(http://www5.epsondevice.com/en/information/support/linux_rtc/)

The registered trademark Linux® is used pursuant to a sublicense from LMI(Linux Mark Institute)

Block diagram

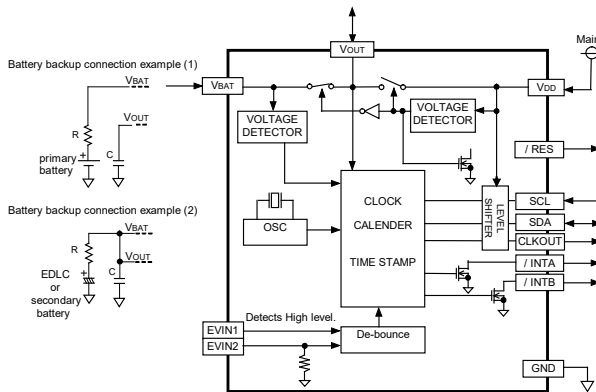

Overview

- **The event detection and Timestamp function**
Dual event detection terminals.
Selectable de-bounce time 35ms or 2s.
Available event detection interrupt output.
- **Power switching functions.**
• An external diode is unnecessary to have a reverse current prevention switch built-in in the VBAT side to connect a primary cell to.
• When VDD is less than 2.4V, an internal source is switched to VBAT, and /RES is Low level. When VDD voltage rises to higher than 2.52V, an internal source is switched to VDD, and /RES is released with 105ms delay.
• Note: When the supply from VBAT, SCL and SDA are disabled.
- **Alarm, Periodic interrupt, 32.768kHz clock output.**
• Available monthly-alarm and weekly- Dual alarm.
• Interrupt period are selectable from 2Hz to Monthly.
• CLKOUT outputs 32.768kHz, it powered from VDD.

Pin function

Signal Name	Input / Output	Function
SCL	Input	I ² C serial clock.
SDA	In/Out	I ² C data in/out.
VDD	—	Main power supply.
VBAT	—	Power supply for backup.
Vout	Output	Switched power out. (maximum output current 20mA)
/ RES	Output	VDD voltage state.
GND	—	Ground
EVIN1	Input	Event detection input 1
EVIN2	Input	Event detection input 2
/ INTA	Output	Interrupt out A.
/ INTB	Output	Interrupt out B.
CLKOUT	Output	32.768kHz output. (CMOS. Can not inhibit.)
N.C.	—	Do not connect.

Terminal connection / External dimensions

(Unit:mm)

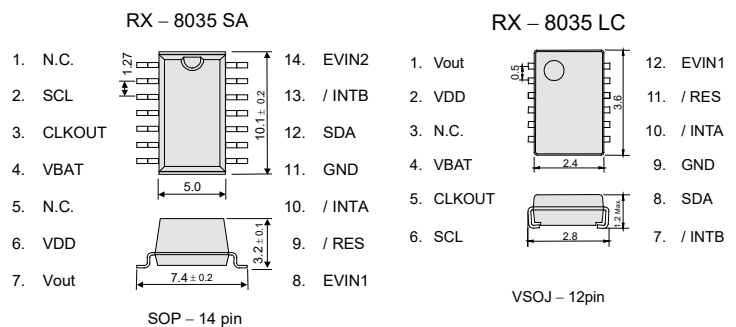

The metal case inside of the molding compound may be exposed on the top or bottom of this product. This purely cosmetic and does not have any effect on quality, reliability or electrical specs.

Prohibition of use of glue after a mount of a product
An LC package product cannot use glue and resin coating.
When such a processing is necessary, please examine a CE package product.

Specifications (characteristics)

* Refer to application manual for details.

Recommended Operating Conditions

Item	Symbol	Conditions	Min.	Typ.	Max.	Unit
Operating voltage	VACCESS	VDD	2.4	3.0	5.5	V
Time keeping voltage	VCLK	VBAT	1.0	3.0	5.5	V
Operating temperature	TOPR	—	-40	+25	+85	°C
Storage temperature	TSTG	—	-55	—	+125	°C

Frequency characteristics

Item	Symbol	Conditions	Rating	Unit
Frequency tolerance	$\Delta f / f$	T _a = +25 °C V _{BAT} = 3.0 V	B: 5 ± 23 ^{*1)} AA: 5 ± 5 ^{*2)} AC: 0 ± 5 ^{*2)}	× 10 ⁻⁶
Oscillation start-up time	t _{STA}	T _a = +25 °C V _{DD} = 3.0 V	1 Max.	s
Frequency / voltage characteristics	f / V	T _a = +25 °C V _{DD} = 2.4 V to 5.5 V	± 1 Max.	× 10 ⁻⁶

*1) Equivalent to ±1 minute of monthly deviation (excluding offset).
*2) Equivalent to ±13 seconds of monthly deviation (excluding offset).

Current consumption characteristics

T_a = -40 °C to +85 °C

Item	Symbol	Conditions	Min.	Typ.	Max.	Unit
Current Consumption	I _{BAT}	RX-8035SA V _{BAT} = 3.0V, V _{DD} = 0.0V SCL=SDA = GND	-	350	1200	nA
		RX-8035LC V _{BAT} = 3.0V, V _{DD} = 0.0V SCL=SDA = GND	-	400	-	-
	I _{DD}	V _{DD} = 3.0V SCL=SDA = GND CLKOUT = open	-	1.40	2.50	μA

Power supply detection voltage

T_a = -40 °C to +85 °C

Item	Symbol	Conditions	Min.	Typ.	Max.	Unit
Voltage of low battery voltage.	V _{LOW}	-	1.10	1.25	1.40	V
Power switching voltage (VDD to VBAT)	V _{D2B}	+25 °C	2.328	2.40	2.472	V

PROMOTION OF ENVIRONMENTAL MANAGEMENT SYSTEM CONFORMING TO INTERNATIONAL STANDARDS

At Seiko Epson, all environmental initiatives operate under the Plan-Do-Check-Action (PDCA) cycle designed to achieve continuous improvements. The environmental management system (EMS) operates under the ISO 14001 environmental management standard.

All of our major manufacturing and non-manufacturing sites, in Japan and overseas, completed the acquisition of ISO 14001 certification.





ISO 14000 is an international standard for environmental management that was established by the International Standards Organization in 1996 against the background of growing concern regarding global warming, destruction of the ozone layer, and global deforestation.

WORKING FOR HIGH QUALITY

In order provide high quality and reliable products and services than meet customer needs, Seiko Epson made early efforts towards obtaining ISO9000 series certification and has acquired ISO9001 for all business establishments in Japan and abroad. We have also acquired IATF 16949 certification that is requested strongly by major automotive manufacturers as standard.

IATF 16949 is the international standard that added the sector-specific supplemental requirements for automotive industry based on ISO9001.

► Explanation of the mark that are using it for the catalog

	► Pb free.
	► Complies with EU RoHS directive. *About the products without the Pb-free mark. Contains Pb in products exempted by EU RoHS directive. (Contains Pb in sealing glass, high melting temperature type solder or other.)
	► Designed for automotive applications such as Car Multimedia, Body Electronics, Remote Keyless Entry etc.
	► Designed for automotive applications related to driving safety (Engine Control Unit, Air Bag, ESC etc).

NOTICE : PLEASE READ CAREFULLY BELOW BEFORE THE USE OF THIS DOCUMENT ©Seiko Epson Corporation 2020

1. The content of this document is subject to change without notice. Before purchasing or using Epson products, please contact with sales representative of Seiko Epson Corporation ("Epson") for the latest information and be always sure to check the latest information published on Epson's official web sites and resources.
2. This document may not be copied, reproduced, or used for any other purposes, in whole or in part, without Epson's prior consent.
3. Information provided in this document including, but not limited to application circuits, programs and usage, is for reference purpose only. Epson makes no guarantees against any infringements or damages to any third parties' intellectual property rights or any other rights resulting from the information. This document does not grant you any licenses, any intellectual property rights or any other rights with respect to Epson products owned by Epson or any third parties.
4. Using Epson products, you shall be responsible for safe design in your products; that is, your hardware, software, and/or systems shall be designed enough to prevent any critical harm or damages to life, health or property, even if any malfunction or failure might be caused by Epson products. In designing your products with Epson products, please be sure to check and comply with the latest information regarding Epson products (including, but not limited to this document, specifications, data sheets, manuals, and Epson's web site). Using technical contents such as product data, graphic and chart, and technical information, including programs, algorithms and application circuit examples under this document, you shall evaluate your products thoroughly both in stand-alone basis and within your overall systems. You shall be solely responsible for deciding whether to adopt/use Epson products with your products.
5. Epson has prepared this document carefully to be accurate and dependable, but Epson does not guarantee that the information is always accurate and complete. Epson assumes no responsibility for any damages you incurred due to any misinformation in this document.
6. No dismantling, analysis, reverse engineering, modification, alteration, adaptation, reproduction, etc., of Epson products is allowed.
7. Epson products have been designed, developed and manufactured to be used in general electronic applications and specifically designated applications ("Anticipated Purpose"). Epson products are NOT intended for any use beyond the Anticipated Purpose that requires particular quality or extremely high reliability in order to refrain from causing any malfunction or failure leading to critical harm to life and health, serious property damage, or severe impact on society, including, but not limited to listed below ("Specific Purpose"). Therefore, you are strongly advised to use Epson products only for the Anticipated Purpose. Should you desire to purchase and use Epson products for Specific Purpose, Epson makes no warranty and disclaims with respect to Epson products, whether express or implied, including without limitation any implied warranty of merchantability or fitness for any Specific Purpose. Please be sure to contact our sales representative in advance, if you desire Epson products for Specific Purpose:
 - Space equipment (artificial satellites, rockets, etc.)/ Transportation vehicles and their control equipment (automobiles, aircraft, trains, ships, etc.) / Medical equipment/ Relay equipment to be placed on sea floor/ Power station control equipment / Disaster or crime prevention equipment/Traffic control equipment/ Financial equipment
 - Other applications requiring similar levels of reliability as the above
8. Epson products listed in this document and our associated technologies shall not be used in any equipment or systems that laws and regulations in Japan or any other countries prohibit to manufacture, use or sell. Furthermore, Epson products and our associated technologies shall not be used for the purposes of military weapons development (e.g. mass destruction weapons), military use, or any other military applications. If exporting Epson products or our associated technologies, please be sure to comply with the Foreign Exchange and Foreign Trade Control Act in Japan, Export Administration Regulations in the U.S.A (EAR) and other export-related laws and regulations in Japan and any other countries and to follow their required procedures.
9. Epson assumes no responsibility for any damages (whether direct or indirect) caused by or in relation with your non-compliance with the terms and conditions in this document or for any damages (whether direct or indirect) incurred by any third party that you give, transfer or assign Epson products.
10. For more details or other concerns about this document, please contact our sales representative.
11. Company names and product names listed in this document are trademarks or registered trademarks of their respective companies.