

KS1100 SERIES PUSHBUTTON SWITCH

ANTI-VANDAL SWITCHES
DETECTOR SWITCHES
DIP SWITCHES
KEYLOCK SWITCHES
NAVIGATION SWITCHES
PUSHBUTTON SWITCHES
ROCKER SWITCHES
ROTARY SWITCHES
SLIDE SWITCHES
SNAP ACTION SWITCHES
TACTILE SWITCHES
TOGGLE SWITCHES
CAP OPTIONS



APPLICATIONS / MARKETS



Audio / Visual



Kiosks



Consumer Electronics



Instrumentation



Vending Machines



Medical Equipment

RoHS

SPECIFICATIONS

Contact Rating: 10mA @ 12VDC Max
Contact Resistance: 100mΩ Max Initial
Insulation Resistance: 100MΩ Min. @ 100VDC
Dielectric Strength: 1,000VAC for 1 Minute
Electrical Life: 50,000,000
Operating Temperature: -10°C to 70°C
Storage Temperature: -10°C to 70°C
Contact Arrangement: SPST
Travel: 2.0mm to Electrical Make
 4.0mm Max Travel
Actuation: 60gf

FEATURES & BENEFITS

- 10mA 12VDC rating
- 1 Pole SPST Momentary Function
- Long Travel
- 50,000,000 Electrical Life
- Low Actuator Force

PART NUMBER CONFIGURATOR

Series

KS1100

Function

OA - Momentary

Circuit

1 - SPST

Actuator

A - 15.2mm Height

Operating Force

F060 - 60 GF

Specifications subject to change without notice



E-SWITCH®

www.e-switch.com

800.867.2717

1

KS1100 SERIES PUSHBUTTON SWITCH

BODY DIMENSIONS & PCB LAYOUT

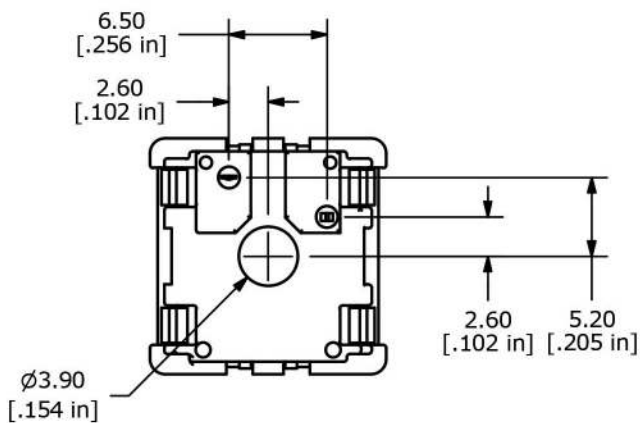
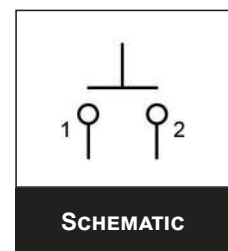
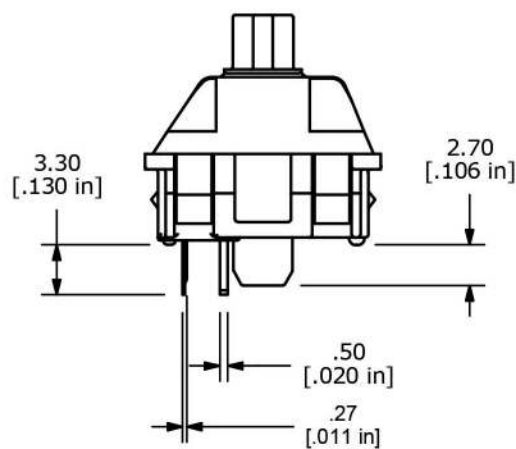
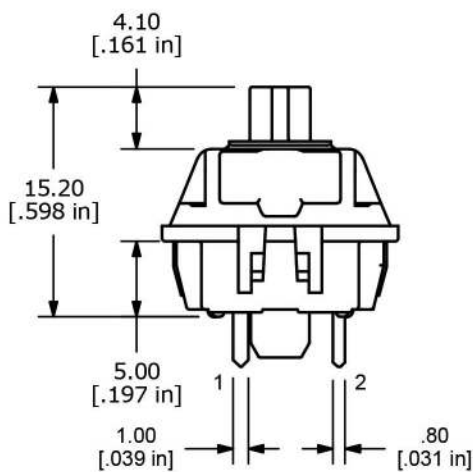
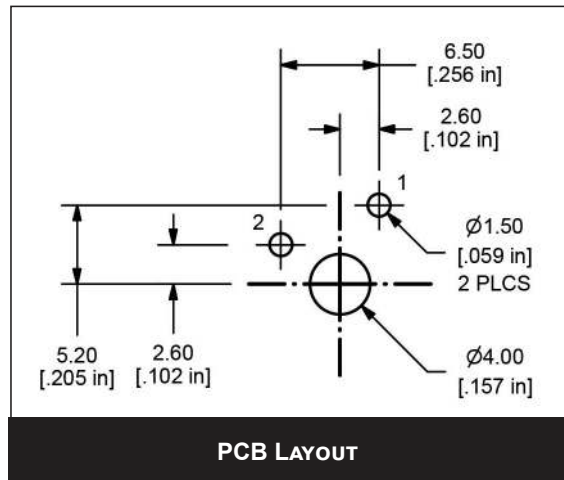
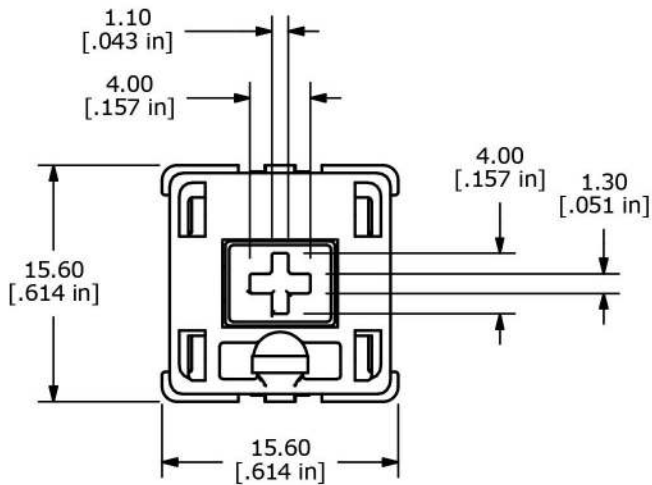

- ANTI-VANDAL SWITCHES
- DETECTOR SWITCHES
- DIP SWITCHES
- KEYLOCK SWITCHES
- NAVIGATION SWITCHES
- PUSHBUTTON SWITCHES**
- ROCKER SWITCHES
- ROTARY SWITCHES
- SLIDE SWITCHES
- SNAP ACTION SWITCHES
- TACTILE SWITCHES
- TOGGLE SWITCHES
- CAP OPTIONS