

DASH NO	CABLE ACCOMMODATED	A HEX
-009	8218, BELDEN 21-597, ESSEX YR23023, BELDEN	.178
-013A	TCC-75-2 8241F, BELDEN	.255
-014	8212, BELDEN	.255
-025	734A TYPE	
-026	735A TYPE	.178
-027	KS19224L2 LUCENT	

DATA CONTAINED IN THIS DOCUMENT IS PROPRIETARY TO TROMPETER ELECTRONICS INC. AND SHALL NOT BE DISCLOSED, COPIED OR USED FOR PROCUREMENT OR MANUFACTURE WITHOUT EXPRESS WRITTEN PERMISSION OF TROMPETER ELECTRONICS INC.

REVISIONS		PLIMWLT	SH 1
REV	DESCRIPTION	DATE	APPROVED
A	PRODUCTION RELEASE		

**RED INDICATES ORIGINAL**

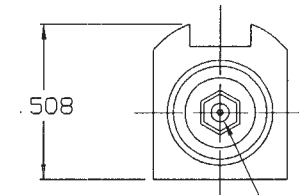
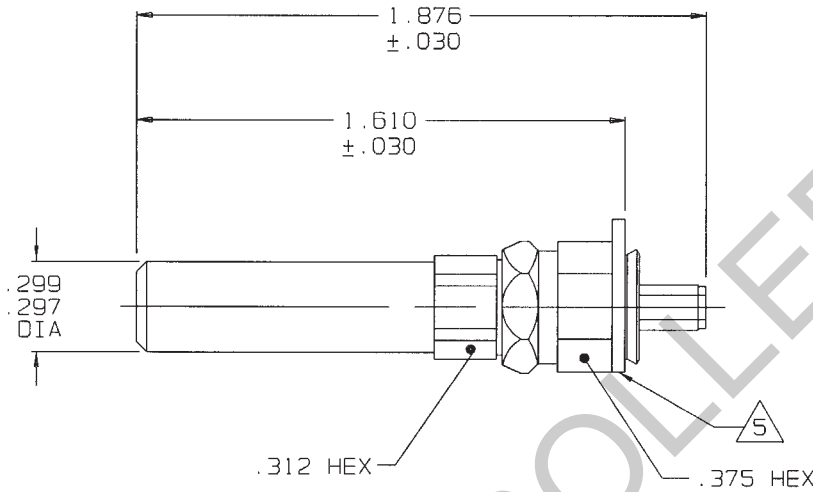

MODEL NO.	TEI P/N
PLIMWLT	1-0604

5 PLATE TO ROTATE FREELY AFTER WITHSTANDING AN AXIAL FORCE OF 25 LBS IN THE DIRECTION OF THE CABLE ENTRY

4 ASSEMBLE IAW TAI-200 EXCEPT INSTALL NUT ASSY OVER CABLE PRIOR TO TERMINATING CONNECTOR

3 SEE TABLE FOR CABLE ACCOMMODATED

2. 75 OHM COAXIAL MINIATURE TOOL CRIMP PATCH PLUG, IN STANDARD CRIMP DESIGN, WITH ENTRY BUSHING

1. FINISH: TFS-1B (2G-GOLD)

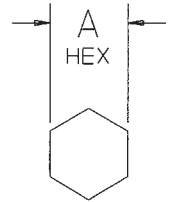

RECOMMENDED  
HEX CRIMP

OUTLINE DRAWING

INTERPRET DRAWING PER MIL-STD-100 DIMENSIONS ARE IN INCHES AND INCLUDE FINISH THICKNESS UNLESS OTHERWISE SPECIFIED		TOL: UNLESS SPECIFIED .XX ± .02 .XXX ± .010 .XXXX		 a cinch connectivity solutions brand	
DRAWN PD	DATE 1-10-02	MATERIAL:			
CHECKED		FINISH:		SIZE	CAGE CODE
QUALITY	1-17-02			A	14949
MANIF	1/17/02			DRAWING NO.	REV.
APPROVED	1/16/02			PLIMWLT	A
CAO FILE NO.	PLIMWLT.PRT	DO NOT SCALE DWG		SCALE	DATE
NEXT ASSY				2/1	1-17-02
				SHEET	1 OF 1