

**NOTES: UNLESS OTHERWISE SPECIFIED**

1. ALL DIMENSIONS APPLY AFTER PLATING.
2. DIMENSION IN FREE STATE.
3. RECOMMENDED SHIELD THICKNESS =  $.006[0.15] + .003[0.08]$
4. REFER TO THE TABLE "A" FOR STENCIL HOLE SIZE.  
BUT, PAD SIZE MUST BE FIXED ALWAYS AS H=5.20 & V=1.0

TABLE "A"		
STENCIL THICKNESS	H	V
0.15	4.60	0.8
0.12	5.00	0.9
0.10	5.20	1.0

UNIT : mm

PICK-UP AREA

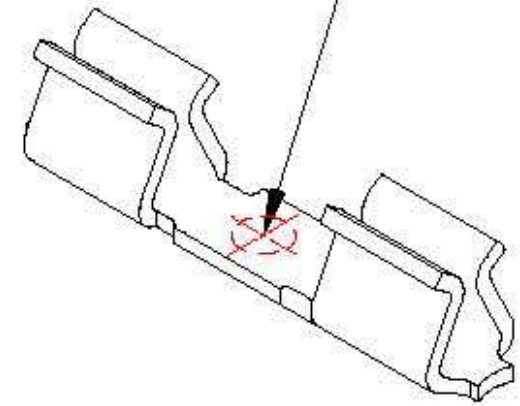

ISOMETRIC VIEW

12mm TAPE PER E.I.A. STD. 481 , 13" REEL ,  
SEE TABLE FOR QTY OF PARTS PER REEL.

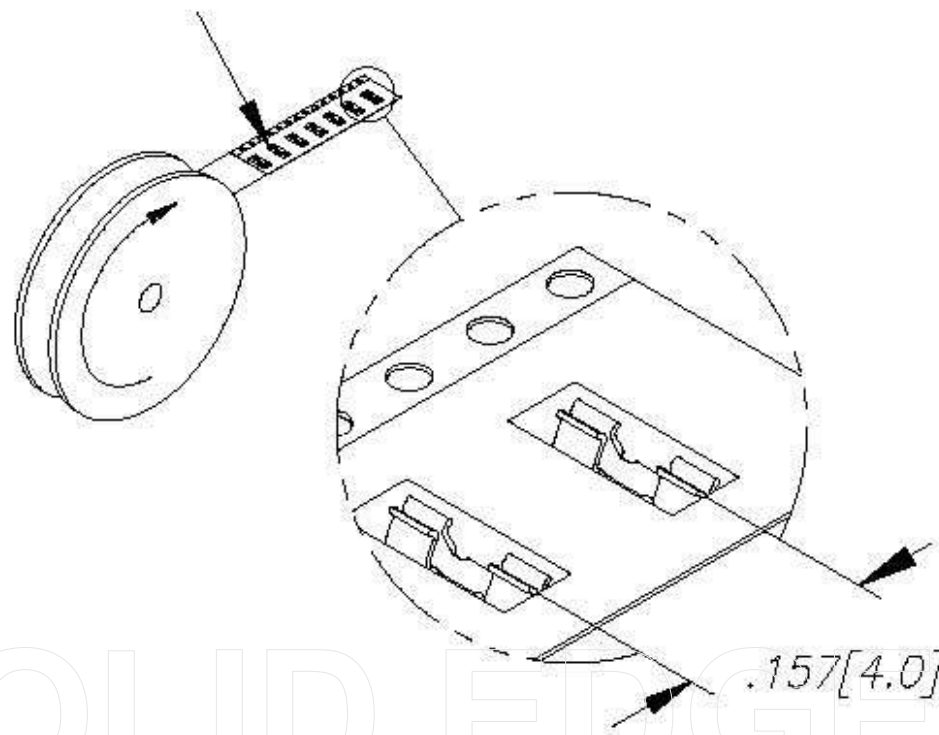

**CUSTOMER DRAWING**

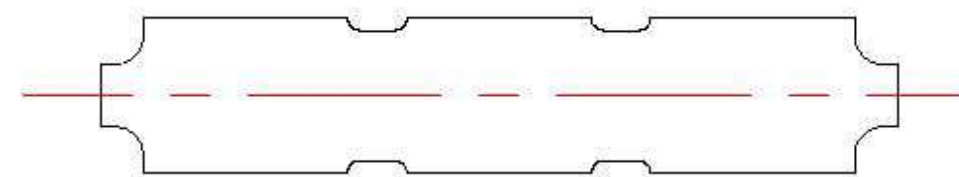
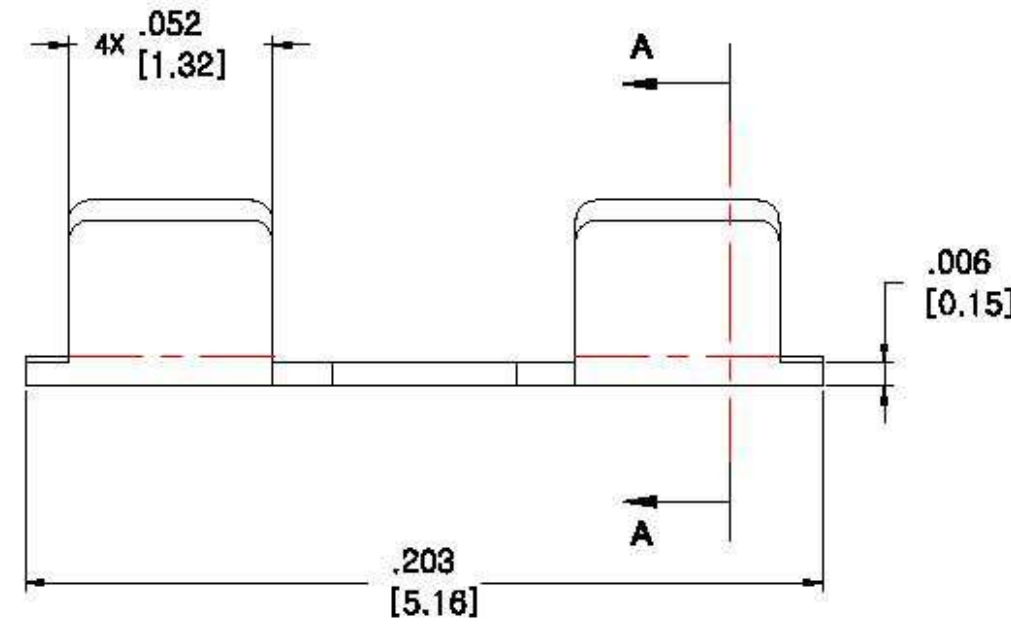
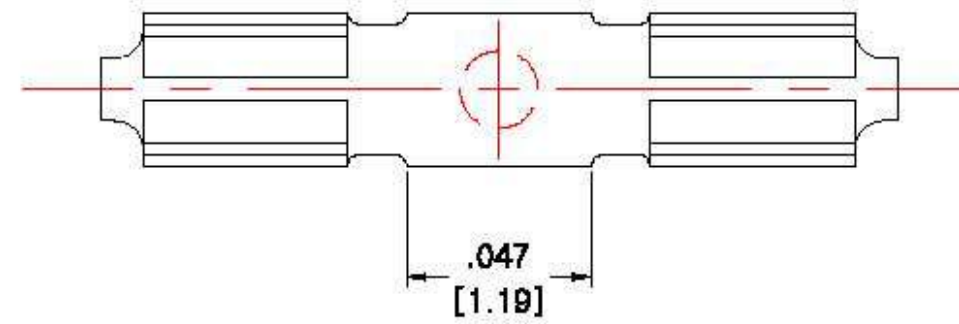

REV	REVISION RECORD	BY	DATE
A	INITIAL RELEASE	YJ.PARK	2008.09.26
B	ADDED STENCIL HOLE SIZE	YJ.PARK	2008.11.20
C	CHANGED RECOMMENDED SHIELD THICKNESS	YJ.PARK	2009.03.04
D	CHANGED PAD SIZE & QUANTITY PER REEL	YJ.PARK	2009.08.31
E	MODIFIED GAP DIMENSION & TOLERANCE	YJ.PARK	2009.12.10

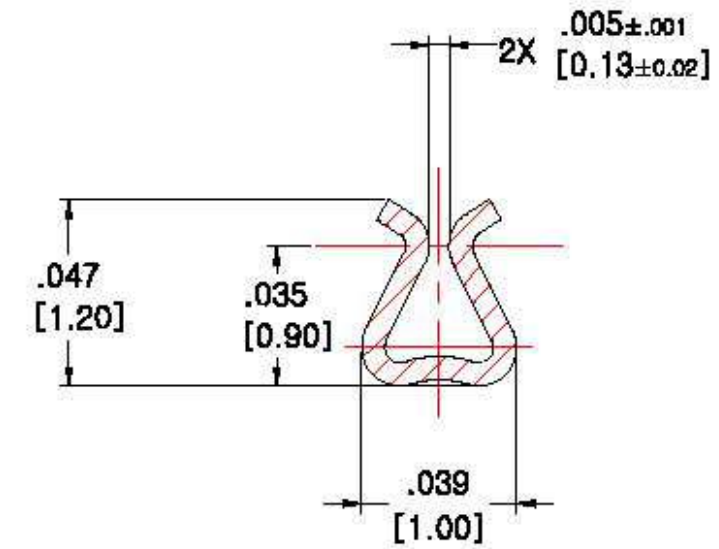
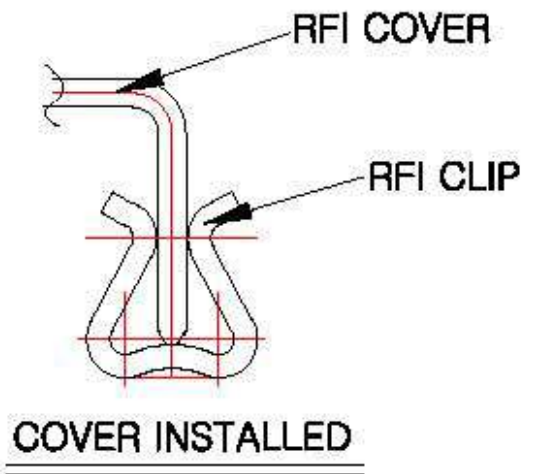

SECTION A-A  
SCALE 1:1

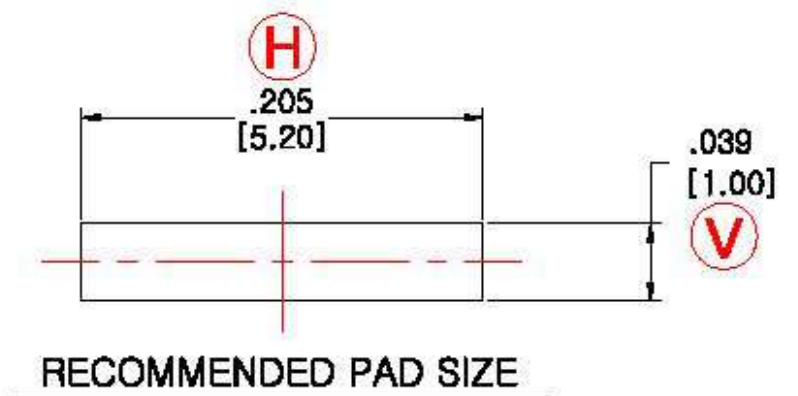

RECOMMENDED PAD SIZE

MATERIAL <b>SUS301</b>	HEAT TREAT	UNLESS OTHERWISE SPECIFIED, ALL DIMENSIONS ARE IN MM. TOLERANCES ARE: 0 ≤ X < 3 : ±0.10 3 ≤ X < 10 : ±0.15 10 ≤ X < 25 : ±0.20 25 ≤ X : ±0.25
FINISH <b>POST-TIN (MATTE)</b>	Unit Qty <b>10,000PCS / REEL</b>	
This drawing and the information set forth hereon are the property of Autossplice, Inc. and are to be held in trust and confidence. Publication, disclosure, or use for any purpose not expressly authorized in writing by Autossplice, Inc. is prohibited.		

<b>autossplice</b> ®		AUTOSPLICE CO., LTD.	
117BL 2LOT Namdong Industrial Complex, Incheon, R.O.Korea		(82)32- 812-9784	
PROJECT	DRAWN BY	YJ.PARK	DATE
	DESIGNED BY	YJ.PARK	DATE
	APPROVED BY	BRIAN.LEE	DATE
		2008.09.26	2008.09.26

TITLE <b>SMT MICRO RFI CLIP(BOTTOM TYPE)</b>			
SIZE <b>A4</b>	DRAWING NUMBER <b>C-ATC-BB-02-001</b>	REV <b>E</b>	
SCALE <b>1:1</b>	WEIGHT	SHEET <b>1 OF 1</b>	