

Printing: ㊦AWM STYLE 2725 80°C 30V  
VW-1 SUPER HIGH SPEED USB Revision 3.0

① Pin Assignment

P1		P2
1	Red	1
2	White	2
3	Green	3
4	Black	4
5	Blue	5
6	Yellow	6
7	Drain	7
8	Orange	8
9	Purple	9
Shell	Braid	Shell

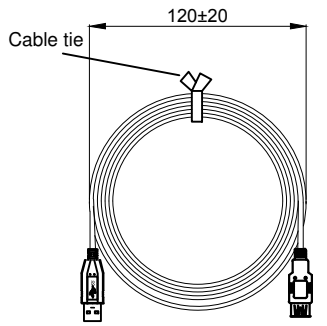

NOTES:

1. Cable Must Be Open, Short, Miswire 100% Test
2. Voltage: 300V DC
3. Contact Resistance: 5ohms max.
4. Insulation Resistance: 10M ohms min.
5. 1Pcs/PE Bag

② WSW P/N	Length(mm)	Qty/Per Carton
A-USB30AM-30AF-050	500±20	200
A-USB30AM-30AF-100	1000±30	150
A-USB30AM-30AF-200	2000±50	100
A-USB30AM-30AF-300	3000±50	70
A-USB30AM-30AF-500	5000±50	50

②	NO.	TITLE	DESCRIPTION
△	Inner Mold	LDPE WHITE	
△	Over Mold	PVC 45P Black	
△	CONN	USB3.0 A/F, Blue PBT, PIN G/F, Shell Ni-Plated	
△	CONN	USB3.0 A/M, Blue PBT, PIN G/F, Shell Ni-Plated	
△	CABLE	UL2725(Rev 3.0), OD:5.5mm BLACK, (1P#30+D+AL+Mylar)*2C+1P#30+2C#24+AL+B	
	NO.	TITLE	DESCRIPTION

G	RoHS compliant Unit: mm	Scale	FREE				Date	Name	Customer-No.
		TOLERANCE					Drawn	07.01.2019	Xavier
H		DIM	TOL	②	Packing quantities& PVC hardness	10.12.2019	Winnie		ASSMANN WSW-No. <b>A-USB30AM-30AF-xxx</b>
				①	Add wire color	07.15.2019	Xavier		Drawing-No. <b>ASS 8452 CA</b>
		①	Drawn	07.01.2019	Xavier			Replace	Sheet
Angle	TOL	Id.	Modification	Date	Name				1/1