

REVISIONS					
P	LTR	DESCRIPTION	DATE	DN	APVD
J		RESIN SUPPLIER CHANGE FOR HOUSING	27MAY2022	SCB	PS

- 1 POINT OF MEASUREMENT FOR PLATING THICKNESS
- 2 THE NOTED DIMENSIONS APPLY AT THE INTERSECTION OF THE POST AND HOUSING
- 3 TRUE POSITION TOLERANCE OF THE POST TIPS APPLIES WHEN THE HEADERS ARE HELD FLAT AGAINST THE PRINTED CIRCUIT BOARD
- 4 FINISH: POSTS, .000030 GOLD IN CONTACT AREA, .000100-.000200 MATTE TIN-LEAD ON SOLDER TAIL, ALL OVER .000050 NICKEL.
- 5 FINISH: POSTS, .000030 GOLD IN CONTACT AREA, .000100-.000200 MATTE TIN ON SOLDER TAIL, ALL OVER .000050 NICKEL.
- 6 OBSOLETE PARTS: OBSOLETE CIS STREAMLINING PER D.RENAUD/D.SINISI

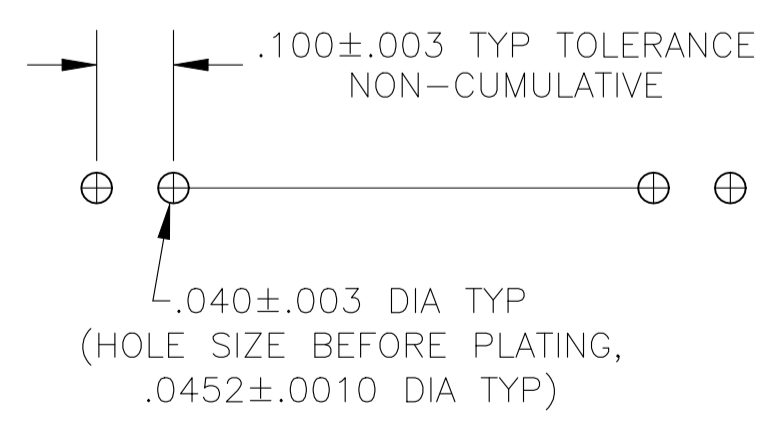
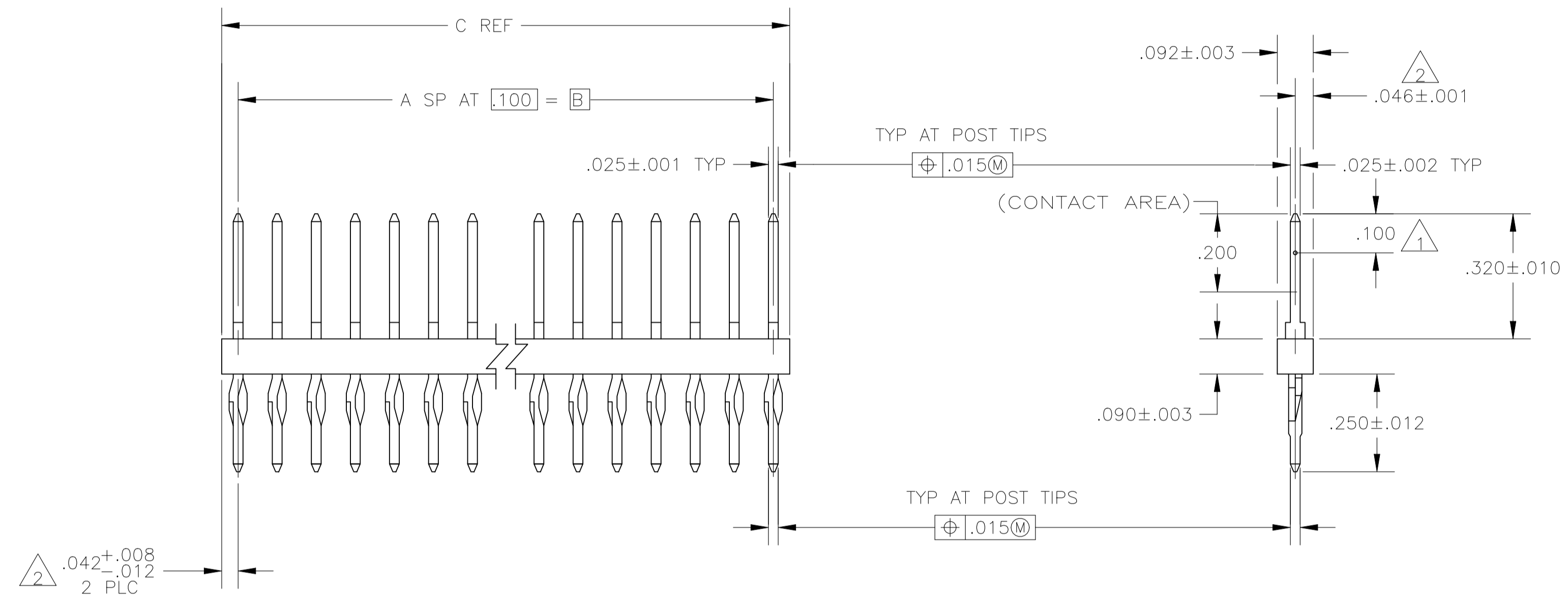

RECOMMENDED HOLE LAYOUT

6	OBSOLETE	2.284	.200	2	3	9-103336-0
6	OBSOLETE	.684	.600	6	7	8-103336-9
6	OBSOLETE	.484	.400	4	5	8-103336-8
6	OBSOLETE	.584	.500	5	6	8-103336-7
6	OBSOLETE	.384	.300	3	4	8-103336-6
6	OBSOLETE	.084	0	0	1	8-103336-5
6	OBSOLETE	.184	.100	1	2	8-103336-4
6	OBSOLETE	3.984	3.900	39	40	8-103336-3
6	OBSOLETE	3.584	3.500	35	36	7-103336-9
6	OBSOLETE	3.184	3.100	31	32	7-103336-5
6	OBSOLETE	2.984	2.900	29	30	7-103336-3
6	OBSOLETE	2.484	2.400	24	25	6-103336-8
6	OBSOLETE	1.984	1.900	19	20	6-103336-3
6	OBSOLETE	1.884	1.800	18	19	6-103336-2
6	OBSOLETE	1.784	1.700	17	18	6-103336-1
6	OBSOLETE	1.684	1.600	16	17	6-103336-0
6	OBSOLETE	1.584	1.500	15	16	5-103336-9
6	OBSOLETE	1.484	1.400	14	15	5-103336-8
6	OBSOLETE	1.384	1.300	13	14	5-103336-7
6	OBSOLETE	1.284	1.200	12	13	5-103336-6
6	OBSOLETE	1.184	1.100	11	12	5-103336-5
6	OBSOLETE	1.084	1.000	10	11	5-103336-4
6	OBSOLETE	.984	.900	9	10	5-103336-3
6	OBSOLETE	.884	.800	8	9	5-103336-2
6	OBSOLETE	.784	.700	7	8	5-103336-1

6	OBSOLETE	.284	.200	2	3	4-103336-0
6	OBSOLETE	.684	.600	6	7	3-103336-9
6	OBSOLETE	.484	.400	4	5	3-103336-8
6	OBSOLETE	.584	.500	5	6	3-103336-7
6	OBSOLETE	.384	.300	3	4	3-103336-6
6	OBSOLETE	.084	0	0	1	3-103336-5
6	OBSOLETE	.184	.100	1	2	3-103336-4
6	OBSOLETE	3.984	3.900	39	40	3-103336-3
6	OBSOLETE	3.884	3.800	38	39	3-103336-2
6	OBSOLETE	3.784	3.700	37	38	3-103336-1
6	OBSOLETE	3.684	3.600	36	37	3-103336-0
6	OBSOLETE	3.584	3.500	35	36	2-103336-9
6	OBSOLETE	3.484	3.400	34	35	2-103336-8
6	OBSOLETE	3.384	3.300	33	34	2-103336-7
6	OBSOLETE	3.284	3.200	32	33	2-103336-6
6	OBSOLETE	3.184	3.100	31	32	2-103336-5
6	OBSOLETE	3.084	3.000	30	31	2-103336-4
6	OBSOLETE	2.984	2.900	29	30	2-103336-3
6	OBSOLETE	2.884	2.800	28	29	2-103336-2
6	OBSOLETE	2.784	2.700	27	28	2-103336-1
6	OBSOLETE	2.684	2.600	26	27	2-103336-0
6	OBSOLETE	2.584	2.500	25	26	1-103336-9
6	OBSOLETE	2.484	2.400	24	25	1-103336-8
6	OBSOLETE	2.384	2.300	23	24	1-103336-7
6	OBSOLETE	2.284	2.200	22	23	1-103336-6
6	OBSOLETE	2.184	2.100	21	22	1-103336-5
6	OBSOLETE	2.084	2.000	20	21	1-103336-4
6	OBSOLETE	1.984	1.900	19	20	1-103336-3
6	OBSOLETE	1.884	1.800	18	19	1-103336-2
6	OBSOLETE	1.784	1.700	17	18	1-103336-1
6	OBSOLETE	1.684	1.600	16	17	1-103336-0
6	OBSOLETE	1.584	1.500	15	16	103336-9
6	OBSOLETE	1.484	1.400	14	15	103336-8
6	OBSOLETE	1.384	1.300	13	14	103336-7
6	OBSOLETE	1.284	1.200	12	13	103336-6
6	OBSOLETE	1.184	1.100	11	12	103336-5
6	OBSOLETE	1.084	1.000	10	11	103336-4
6	OBSOLETE	.984	.900	9	10	103336-3
6	OBSOLETE	.884	.800	8	9	103336-2
6	OBSOLETE	.784	.700	7	8	103336-1

PLATING	C	B	A	NO OF POSN	ASSEMBLY PART NUMBER
---------	---	---	---	------------	----------------------

PLATING	C	B	A	NO OF POSN	ASSEMBLY PART NUMBER
---------	---	---	---	------------	----------------------

THIS DRAWING IS A CONTROLLED DOCUMENT.

DIMENSIONS: INCHES	TOLERANCES UNLESS OTHERWISE SPECIFIED:	DIN H. MOLL 16 JULY 87	TE Connectivity
0 PLC ± -	1 PLC ± -	CHK L.A. MAYER 16 JULY 87	
2 PLC ± -	3 PLC ± .005	APVD T.C. CLARK 17 JULY 87	NAME
4 PLC ± -	ANGLES ± -		PRODUCT SPEC
MATERIAL	FINISH SEE TABLE		APPLICATION SPEC
		SIZE CAGE CODE DRAWING NO	RESTRICTED TO
		WEIGHT	A1 00779 C=103336
		CUSTOMER DRAWING	SCALE 4:1 SHEET 1 of 1 REV J