



Title	<i>Reference Design Report for a 6 W Constant Voltage (CV) Adapter Using LNK625PG</i>
Specification	90 – 265 VAC Input; 5 V, 1.2 A Output
Application	Low-Cost Charger or Adapter
Author	Applications Engineering Department
Document Number	RDR-201
Date	November 11, 2008
Revision	1.5

Summary and Features

- Eliminates optocoupler and all secondary side control circuitry
- EcoSmart® – Easily meets all existing and proposed international energy efficiency standards – China (CECP) / EISA / Energy STAR / European Commission
 - ON/OFF control provides constant efficiency event at very light loads
 - No-load consumption <100 mW at 265 VAC
 - Meets ENERGY STAR 2.0 active mode efficiency
 - 76 % vs 70 % requirement at board
 - 73 % vs 70 % requirement at end of 6 ft, 315 mΩ output cable
 - Ultra-low leakage current: <5 μA at 265 VAC input (no Y capacitor required)
- Over-temperature protection – tight tolerance (±5%) with hysteretic recovery for safe PCB temperatures under all conditions
- Auto-restart output short circuit and open-loop protection
- Easy compliance to EN550022 and CISPR-22 Class B EMI standards
- Green package: halogen free and RoHS compliant

PATENT INFORMATION

The products and applications illustrated herein (including transformer construction and circuits external to the products) may be covered by one or more U.S. and foreign patents, or potentially by pending U.S. and foreign patent applications assigned to Power Integrations. A complete list of Power Integrations' patents may be found at www.powerint.com. Power Integrations grants its customers a license under certain patent rights as set forth at <<http://www.powerint.com/ip.htm>>.

Power Integrations

5245 Hellyer Avenue, San Jose, CA 95138 USA.

Tel: +1 408 414 9200 Fax: +1 408 414 9201

www.powerint.com

Table of Contents

1	Introduction.....	3
2	Power Supply Specification	4
3	Schematic.....	5
4	Circuit Description	6
4.1	Input and EMI Filtering	6
4.2	LinkSwitch-CV Device	6
4.3	Primary Circuit.....	6
4.4	Output Rectification	7
4.5	Feedback Winding.....	7
5	PCB Layout	8
6	Bill of Materials	9
7	Transformer Specification.....	10
7.1	Electrical Diagram	10
7.2	Electrical Specifications.....	10
7.3	Materials.....	10
7.4	Transformer Build Diagram	11
7.5	Transformer Construction.....	11
8	Transformer Spreadsheets.....	12
9	Performance Data	15
9.1	Active Mode Efficiency	15
9.2	Energy Efficiency Requirements	16
9.2.1	USA Energy Independence and Security Act 2007	17
9.2.2	ENERGY STAR EPS Version 2.0	18
9.3	No-load Input Power.....	19
9.4	Regulation	19
9.4.1	Load	19
9.4.2	Line	20
10	Thermal Performance	21
11	Waveforms.....	22
11.1	Drain Voltage and Current, Normal Operation.....	22
11.2	Output Voltage Start-up Profile.....	23
11.3	Drain Voltage and Current Start-up Profile	23
11.4	Load Transient Response (75% to 100% Load Step)	23
11.5	Output Ripple Measurements.....	25
11.5.1	Ripple Measurement Technique	25
11.5.2	Measurement Results	26
12	Line Surge.....	27
13	Conducted EMI	28
14	Revision History	29

Important Note:

Although this board is designed to satisfy safety isolation requirements, the engineering prototype has not been agency approved. Therefore, all testing should be performed using an isolation transformer to provide the AC input to the prototype board.



1 Introduction

This document is an engineering report describing a universal input, 5 V, 6 W output Flyback power supply. This reference design is based on the LinkSwitch-CV family of devices and utilizes the LNK625PG.

The document contains the power supply specification, schematic, bill of materials, transformer documentation, printed circuit layout, and performance data.



Figure 1 – Populated Circuit Board Photograph.

2 Power Supply Specification

Description	Symbol	Min	Typ	Max	Units	Comment
Input						
Voltage	V_{IN}	90		265	VAC	2 Wire – no P.E.
Frequency	f_{LINE}	47	50/60	64	Hz	
No-load Input Power (230 VAC)				90	mW	
Output						
Output Voltage	V_{OUT}	4.75	5.0	5.25	V	± 5% 20 MHz bandwidth
Output Ripple Voltage	V_{RIPPLE}		100		mV	
Output Current	I_{OUT}	0		1.2	A	
Total Output Power						
Continuous Output Power	P_{OUT}	6			W	
Efficiency						
Full Load	η η_{CBL}	76	71		% %	Measured at P_{OUT} 25 °C At board terminals At end of 6 ft, 315 mΩ output cable
Required average efficiency at 25, 50, 75 and 100 % of P_{OUT}	$\eta_{ES2.0}$	70			%	Per ENERGY STAR V2.0
Measured average efficiency		76			%	At board
		73			%	At end of 6 ft, 315 mΩ output cable
Environmental						
Conducted EMI		Meets CISPR22B / EN55022B				1.2/50 μs surge, IEC 1000-4-5, Series Impedance: Differential Mode: 2 Ω Common Mode: 12 Ω
Safety		Designed to meet IEC950 / UL1950 Class II				
Line Surge						
Differential Mode (L1-L2) Common mode (L1/L2-PE)		1 2			kV kV	
Ambient Temperature	T_{AMB}	0	25	40	°C	Free convection, sea level



3 Schematic

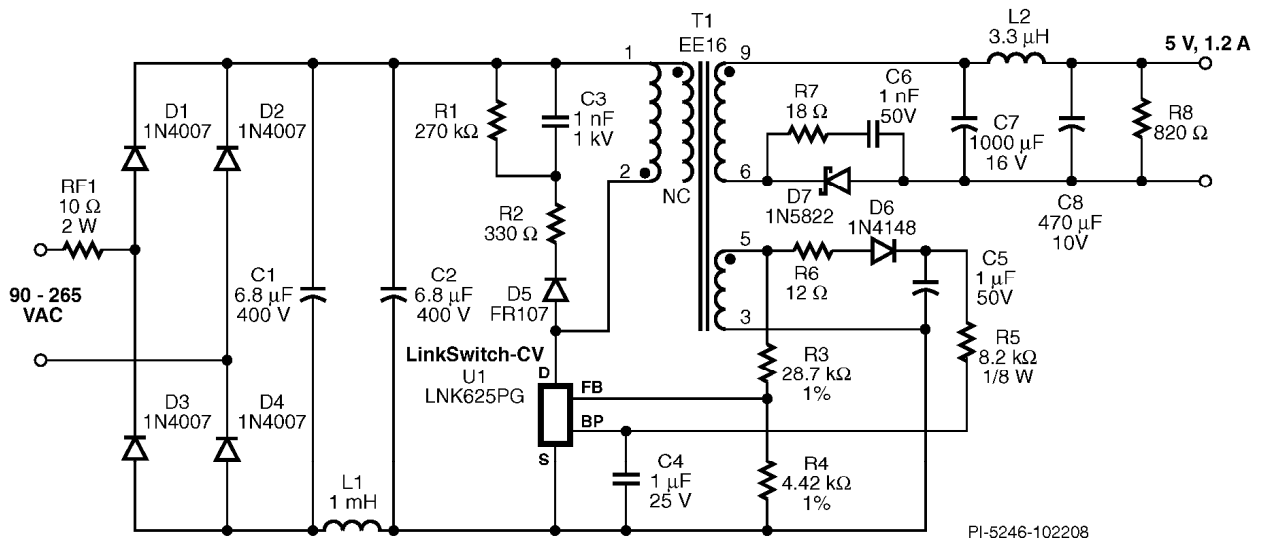

Figure 2 – Schematic



4 Circuit Description

The schematic in Figure 2 shows an adapter design using the LNK625PG that provides very tight constant voltage (CV) performance. The circuit is designed to operate from 90 VAC to 265 VAC input, with an output voltage of 5 V providing a maximum load current of 1.2 A. It consumes very little standby power and uses no Y-Capacitor to meet stringent EMI requirements. The adapter also meets and exceeds both CEC and Energy Star 2.0 regulations.

4.1 Input and EMI Filtering

Diodes D1 through D4 form a full wave rectifier. The rectified DC is then filtered by capacitors C1 and C2. Inductor L1 forms a pi (π) filter with capacitors C1 and C2 which helps to reduce differential EMI noise. This filtering, together with the integrated switching frequency jitter provided in U1 and transformer E-Shield techniques, provide a generous EMI margin without the need for a Y capacitor across the primary and secondary windings of transformer T1.

4.2 LinkSwitch-CV Device

The LinkSwitch-CV family of devices has been developed to cost effectively replace all existing solutions in low power adapter applications. It is optimized for constant voltage (CV) adapter applications while using minimal external parts including the complete elimination of the optocoupler and shunt regulator.

The LNK625PG monolithically integrates the 700 V power MOSFET switch and controller, which consists of an oscillator, feedback (sense and logic) circuit, 6 V regulator, BYPASS pin programming functions, over-temperature protection, frequency jittering, current limit circuit and leading-edge blanking.

The LNK625PG also provides a sophisticated range of protection features including auto-restart for control loop component open/short circuit faults and output short circuit conditions. The use of a low auto-restart on time reduces the power delivered by more than 95 % for output short circuits and control loop faults. Accurate hysteretic thermal shutdown ensures safe average PCB temperatures under all conditions. Extended creepage distance between high and low voltage pins prevent arcing and helps meet safety requirements. *LinkSwitch-CV* also can be used without a bias winding as the IC is completely self biased.

4.3 Primary Circuit

During U1's on time current flows through the primary winding of transformer T1 and stores energy in its magnetic field. During U1's off time, the energy stored in the transformer is transferred to the secondary side, delivering current to both the output capacitors and the load.



The clamp circuit formed by resistors R1 and R2 along with blocking diode D5 and capacitor C3 ensures that the drain node voltage is well below the 700 V rating of the internal MOSFET of U1. The clamp circuit is also carefully designed to reduce and dampen any oscillation present in the voltage spike caused by the transformer's leakage inductance.

4.4 Output Rectification

The secondary output is rectified by diode D7 which is placed in the return leg to help reduce EMI and simplify the transformer construction. An RC snubber circuit composed of resistor R7 and capacitor C6 is placed across the output diode to also reduce high frequency EMI. A stable output voltage is maintained by capacitor C7.

Inductor L2 and capacitor C8 form an LC post filter which helps to attenuate switching noise and reduces output ripple. Resistor R8 is a preload resistor whose value has been empirically chosen to provide the best possible regulation at light loads without significantly affecting no-load input power or efficiency.

4.5 Feedback Winding

LinkSwitch-CV eliminates the need for an optocoupler for tight output voltage regulation, as good as $\pm 5\%$, through the use of a feedback winding. The feedback (FB) pin voltage, which is derived from the voltage divider formed by resistors R3 and R4, is sampled approximately 2.5 μs after U1's internal MOSFET turns off. Based upon this information the device regulates the output voltage.

The feedback winding was also designed with more turns than necessary so that it may act as a bias winding. The winding provides bias current to U1 through the bypass pin (BP) and reduces the input power consumption during light loads and no-load conditions. Resistor R6 helps to dampen out any ringing present on the feedback winding and ensures that the waveform at the FB pin at 2.5 μs is free from any ringing. Capacitor C5 provides a stable bias voltage while resistor R5 is chosen to supply the necessary BP pin current. Capacitor C4 is the BP pin capacitor and should be placed as close as possible to the BP pin and source pins of the device.



5 PCB Layout

Notable layout design points are:

- 1 A spark gap and associated slot in the PCB between the primary and secondary is placed to protect the power supply from electro-static discharge (ESD).
 - The preferential arcing point routes the energy from ESD discharges back to the AC input, away from the transformer and primary circuitry.
 - The trace connected to the AC input side of the spark gap is spaced away from the rest of the board and its components to prevent arc discharges to other sections of the circuit.
- 2 The drain trace length (pin 4 of U1) has been minimized to reduce EMI.
- 3 Clamp and output diode loop areas are minimized to reduce EMI.
- 4 A large copper area around the (electrically quiet) Source pins is used to provide heatsinking. Provide sufficient copper area to keep the source pin temperature below 90 °C.
- 5 The AC input is located away from switching nodes to minimize noise coupling that may bypass input filtering.
- 6 Place C4 (the bypass capacitor) as close as possible to the BYPASS pin on U1.

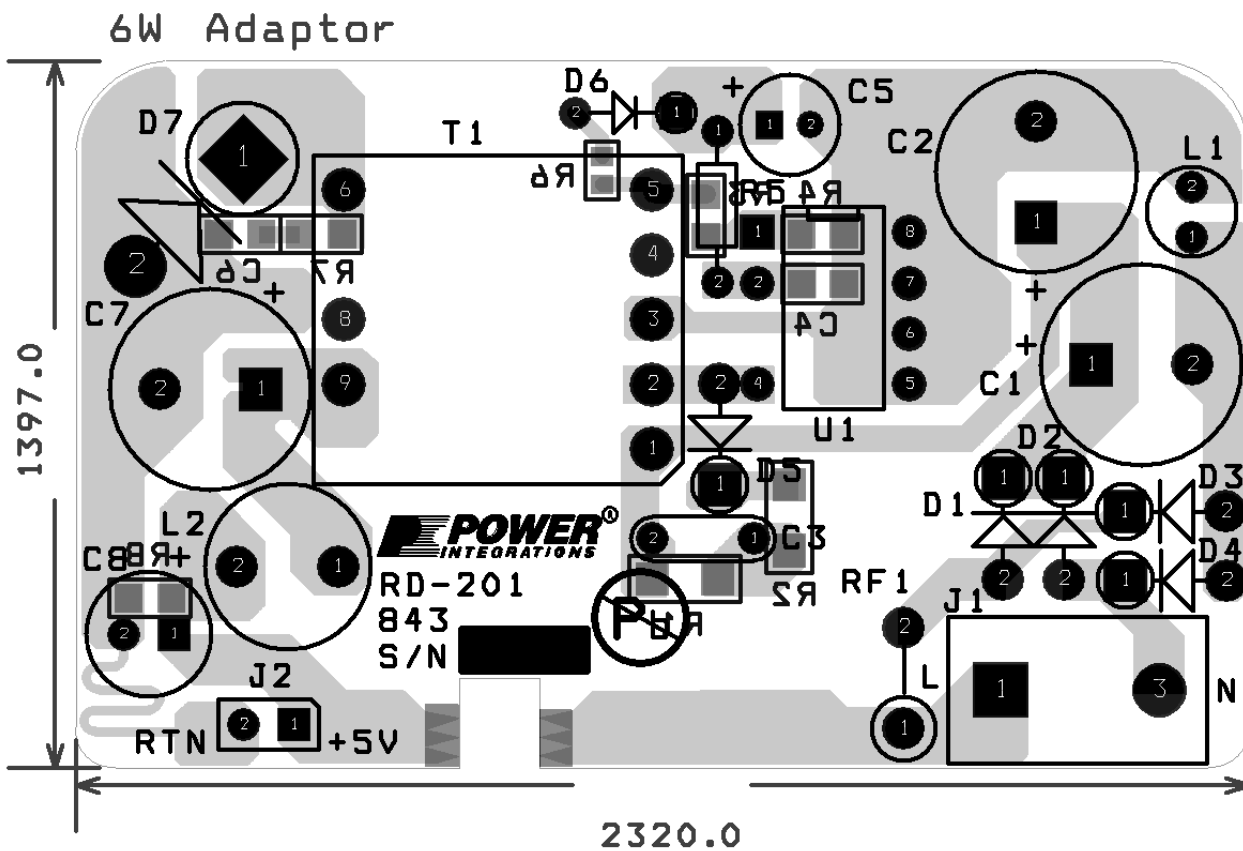

6 Bill of Materials

Item	Qty	Ref Des	Description	Manufacturer Part Number	Manufacturer
1	2	C1 C2	6.8 μ F, 400 V, Electrolytic, (10 x 16)	EKXG401ELL6R8MJ16S	Nippon Chemi-Con
2	1	C3	1 nF, 1 kV, Disc Ceramic	ECK-D3A102KBP	Panasonic - ECG
3	1	C4	1 μ F, 25 V, Ceramic, X7R, 0805	ECJ-2FB1E105K	Panasonic
4	1	C5	1 μ F, 50 V, Electrolytic, Gen. Purpose, (5 x 11)	EKMG500ELL1R0ME11D	Nippon Chemi-Con
5	1	C6	1 nF, 50 V, Ceramic, X7R, 0805	ECJ-2VB1H102K	Panasonic
6	1	C7	1000 μ F, 16 V, Electrolytic, Very Low ESR, 23 m Ω , (10 x 20)	EKZE160ELL102MJ20S	Nippon Chemi-Con
7	1	C8	470 μ F, 10 V, Electrolytic, Very Low ESR, 72 m Ω , (8 x 11.5)	EKZE100ELL471MHB5D	Nippon Chemi-Con
8	4	D1 D2 D3 D4	1000 V, 1 A, Rectifier, DO-41	1N4007-E3/54	Vishay
9	1	D5	1000 V, 1 A, Fast Recovery Diode, DO-41	FR107-T-F	Diodes Inc.
10	1	D6	75 V, 300 mA, Fast Switching, DO-35	1N4148	Vishay
11	1	D7	40 V, 3 A, Schottky, DO-41	1N5822	Vishay
12	1	J1	3 Position (1 x 3) header, 0.156 pitch, Vertical	26-48-1031	Molex
13	1	J2	2 Position (1 x 2) header, 0.1 pitch, Vertical	22-03-2021	Molex
14	1	L1	1 mH, 0.15 A, Ferrite Core	SBCP-47HY102B	Tokin
15	1	L2	3.3 μ H, 5.5 A	RL622-3R3K-RC	JW Miller
16	1	R1	270 k, 5%, 1/4 W, Metal Film, 1206	ERJ-8GEYJ274V	Panasonic
17	1	R2	330 Ω , 5%, 1/4 W, Metal Film, 1206	ERJ-8GEYJ331V	Panasonic
18	1	R3	28.7 k Ω , 1%, 1/8 W, Metal Film, 0805	ERJ-6ENF2872V	Panasonic
19	1	R4	4.42 k Ω , 1%, 1/8 W, Metal Film, 0805	ERJ-6ENF4421V	Panasonic
20	1	R5	8.2 k Ω , 5%, 1/8 W, Carbon Film	CFR-12JB-8K2	Yageo
21	1	R6	12 Ω , 5%, 1/10 W, Metal Film, 0603	ERJ-3GEYJ120V	Panasonic
22	1	R7	18 Ω , 5%, 1/8 W, Metal Film, 0805	ERJ-6GEYJ180V	Panasonic
23	1	R8	820 Ω , 5%, 1/8 W, Metal Film, 0805	ERJ-6GEYJ821V	Panasonic
24	1	RF1	10 Ω , 2 W, Fusible/Flame Proof Wire Wound	CRF253-4 10R	Vitrohm
25	1	T1	Bobbin, EE16, Horizontal, 10 pins	PM-9820 Santronics Würth Electronics Ice Components Precision Electronics	Ho Jinn Plastic Elect. Co. SNX R1494 750811016 TP08152 019-6361-00R
26	1	U1	LinkSwitch-II, LNK625PG, CV, DIP-8C	LNK625PG	Power Integrations



7 Transformer Specification

7.1 Electrical Diagram

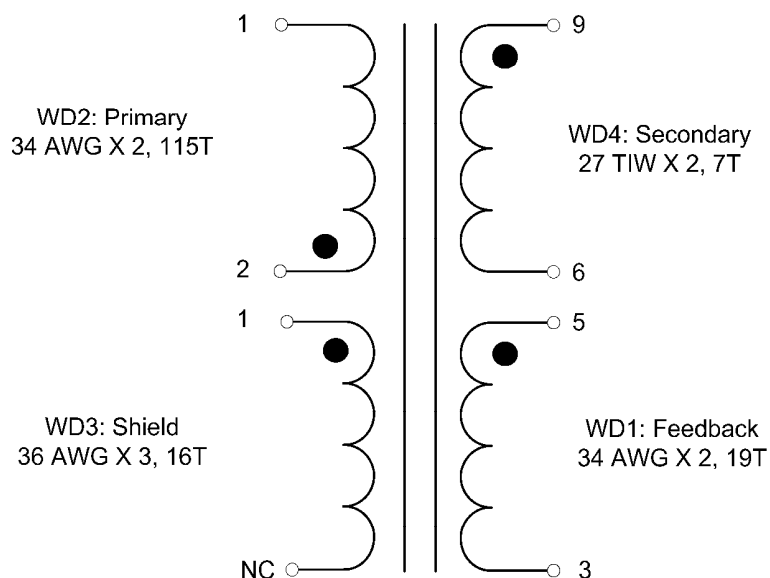

Figure 4 – Transformer Electrical Diagram.

7.2 Electrical Specifications

Electrical Strength	1 second, 60 Hz, from Pins 1-2 to Pins 6-9	3000 VAC
Primary Inductance	Pins 1-2, all other windings open	1.67 mH $\pm 10\%$
Resonant Frequency	Pins 1-2, all other windings open	500 kHz (Min.)
Primary Leakage Inductance	Pins 1-2, with Pins 6,9,3 and 5 shorted.	100 μ H (Max.)

7.3 Materials

Item	Description
[1]	Core: EE16, NC-2H or equivalent, gapped for 126 nH/T ²
[2]	Bobbin: EE16, Horizontal, 10 pins, (5/5)
[3]	Magnet wire: #34 AWG, double coated.
[4]	Magnet wire: #36 AWG, double coated.
[5]	Triple Insulated wire: #27 TIW
[6]	Tape: 3M 1298 Polyester Film, 2 mils thick, 8.6 mm wide.
[7]	Varnish



7.4 Transformer Build Diagram

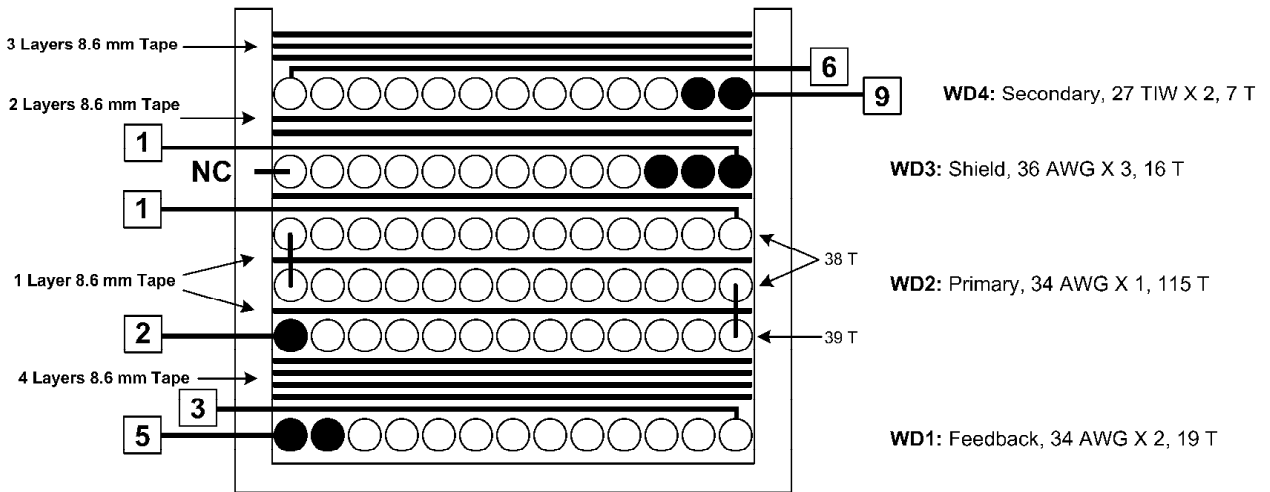

Figure 5 – Transformer Build Diagram.

7.5 Transformer Construction

Bobbin Preparation	Pull pins 7 and 10. Orient the bobbin with primary pins on the left hand side. Winding direction is clockwise.
Winding 1: Feedback	Start on pin 5 and wind 19 turns of bifilar item [3] from left to right terminating on pin 3.
Insulation	Apply 4 layers of tape item [6].
Winding 2: Primary Winding	Start on pin 2 and wind 39 turns of item [3], with tight tension, from left to right filling one layer. Apply one layer of tape item [6]. Continue winding 38 turns of item [3] from right to left and apply one layer of tape item [6]. Wind the remaining 38 turns of item [3] from left to right and terminate the winding on pin 1.
Insulation	Apply one layer of tape item [6].
Winding 3: Shield	Start on any temporary secondary pin, leaving extra wire, and wind 16 turns of trifilar item [4] from right to left filling one layer. Secure the winding temporarily with tape and cut the finish end of the winding. Move the starting end of the winding to pin 1.
Insulation	Wrap two complete layers of tape over any leads of the previous winding.
Winding 4: Secondary	Start on pin 9 and wind 7 turns of item [6] from right to left terminating on pin 6.
Insulation	Apply 2 layers of tape item [6]
Assembly	Assemble core halves and tape together after properly gapping center leg of core.
Finish	Dip Varnish



8 Transformer Spreadsheets

ACDC_LNK-CV_102208; Rev.1.1; Copyright Power Integrations 2008	INPUT	INFO	OUTPUT	UNIT	ACDC_LNK-CV_102208_Rev1-1.xls; LinkSwitch-CV Continuous/Discontinuous Flyback Transformer Design Spreadsheet
ENTER APPLICATION VARIABLES					RDk-201: 5 V, 6 W Adapter Design
VACMIN	90			Volts	Minimum AC Input Voltage
VACMAX	265			Volts	Maximum AC Input Voltage
fL	50			Hertz	AC Mains Frequency
VO	5.00			Volts	Output Voltage
PO	6.00			Watts	Output Power
n	0.72				Efficiency Estimate
Z			0.5		Loss Allocation Factor
tC			3	mSeconds	Bridge Rectifier Conduction Time Estimate
CIN	13.60			uFarads	Input Filter Capacitor

ENTER LinkSwitch-CV VARIABLES					
LinkSwitch-CV	LNK625P		LNK625P		Chosen LinkSwitch-CV device
ILIMITMIN			0.307	Amps	LinkSwitch-CV Minimum Current Limit
ILIMITMAX			0.353	Amps	LinkSwitch-CV Maximum Current Limit
fS			100000	Hertz	LinkSwitch-CV Switching Frequency
I2FMIN			9801	A ² Hz	LinkSwitch-CV Min I2F (power Coefficient)
I2FMAX			12741	A ² Hz	LinkSwitch-CV Max I2F (power Coefficient)
VOR			90	Volts	Reflected Output Voltage
VDS			10	Volts	LinkSwitch-CV on-state Drain to Source Voltage
VD			0.5	Volts	Output Winding Diode Forward Voltage Drop
DCON			5.11	us	Output Diode conduction time
KP_TRANSIENT			0.82		Worst case ripple to peak current ratio. Maintain KP_TRANSIENT below 0.25

ENTER TRANSFORMER CORE/CONSTRUCTION VARIABLES					
Core Type	Auto		EE16		Transformer Core size
Core		EE16		P/N:	PC40EE16-Z
Bobbin		EE16_ BOBBIN		P/N:	BE-16-118CPH
AE			0.192	cm ²	Core Effective Cross Sectional Area
LE			3.5	cm	Core Effective Path Length
AL			1140	nH/T ²	Ungapped Core Effective Inductance
BW			8.5	mm	Bobbin Physical Winding Width
M			0.00	mm	Safety Margin Width (Half the Primary to Secondary Creepage Distance)
L			3		Number of Primary Layers



NS			7		Number of Secondary Turns
DC INPUT VOLTAGE PARAMETERS					
VMIN			87	Volts	Minimum DC Input Voltage
VMAX			375	Volts	Maximum DC Input Voltage
FEEDBACK VARIABLES					
NFB	19.00		19.00		Feedback winding number of turns
VFLY			14.93	Volts	Voltage on the Feedback winding when LinkSwitch-CV turns off
RUPPER			28.70	k-ohms	Upper resistor of feedback network
RLOWER			4.53	k-ohms	Lower resistor of feedback network
Fine Tuning Section					
Measured Output Voltage	5.10		5.10	k-ohms	Actual (Measured) Voltage at the output of power supply
RLOWER FINE			4.42	k-ohms	Adjusted (Fine tuned) value of lower resistor (RLOWER). Do not change value of RUPPER

Bias Winding Parameters					
Add Bias winding	YES		NO		Bias winding is not necessary. The feedback winding itself can be used as a bias winding
VB			N/A	Volts	Bias Winding Voltage
NB			N/A		Number of Bias winding turns. Bias winding is assumed to be AC stacked on top of the Feedback winding

CURRENT WAVEFORM SHAPE PARAMETERS					
DMAX			0.54		Maximum Duty Cycle
IAVG			0.10	Amps	Average Primary Current
IP			0.31	Amps	Minimum Peak Primary Current
IR			0.26	Amps	Primary Ripple Current
IRMS			0.14	Amps	Primary RMS Current

TRANSFORMER PRIMARY DESIGN PARAMETERS					
LPMIN			1499	uHenries	Minimum Primary Inductance
LP_TYP			1649	uHenries	Typical (Nominal) Primary Inductance
LP_TOL			10		Tolerance of Primary inductance
NP			115		Primary Winding Number of Turns
ALG			126	nH/T^2	Gapped Core Effective Inductance
BM			2474	Gauss	Maximum Flux Density, (BM<2500) Calculated at typical current limit and typical primary inductance



BP			2887	Gauss	Peak Flux Density, (BP<3100) Calculated at maximum current limit and maximum primary inductance
BAC			908	Gauss	AC Flux Density for Core Loss Curves (0.5 X Peak to Peak)
ur			1654		Relative Permeability of Ungapped Core
LG			0.19	mm	Gap Length (Lg > 0.1 mm)
BWE			25.5	mm	Effective Bobbin Width
OD			0.22	mm	Maximum Primary Wire Diameter including insulation
INS			0.04	mm	Estimated Total Insulation Thickness (= 2 * film thickness)
DIA			0.18	mm	Bare conductor diameter
AWG			34	AWG	Primary Wire Gauge (Rounded to next smaller standard AWG value)
CM			40	Cmils	Bare conductor effective area in circular mils
CMA			285	Cmils/Amp	Primary Winding Current Capacity (200 < CMA < 500)

TRANSFORMER SECONDARY DESIGN PARAMETERS

Lumped parameters

ISP			5.02	Amps	Peak Secondary Current
ISRMS			2.14	Amps	Secondary RMS Current
IO			1.20	Amps	Power Supply Output Current
IRIPPLE			1.77	Amps	Output Capacitor RMS Ripple Current
CMS			428	Cmils	Secondary Bare Conductor minimum circular mils
AWGS			23	AWG	Secondary Wire Gauge (Rounded up to next larger standard AWG value)
DIAS			0.58	mm	Secondary Minimum Bare Conductor Diameter
ODS			1.21	mm	Secondary Maximum Outside Diameter for Triple Insulated Wire
INSS			0.32	mm	Maximum Secondary Insulation Wall Thickness

VOLTAGE STRESS PARAMETERS

VDRAIN			584	Volts	Maximum Drain Voltage Estimate (Includes Effect of Leakage Inductance)
PIVB			N/A	Volts	Bias Diode Maximum Peak Inverse Voltage
PIVS			28	Volts	Output Rectifier Maximum Peak Inverse Voltage



9 Performance Data

All measurements performed at room temperature, 60 Hz input frequency unless otherwise stated.

9.1 Active Mode Efficiency

Efficiency was measured at the end of a AWG24 cable 6 ft in length (cable resistance = 315 mΩ)

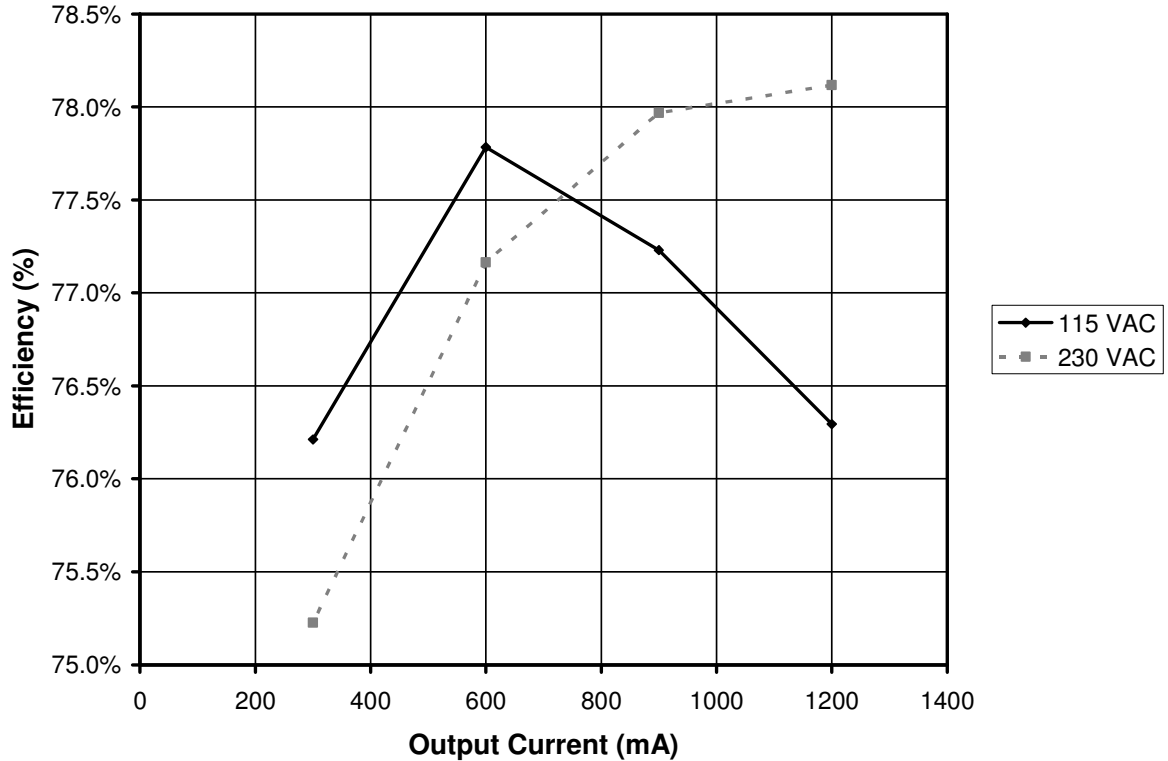

Figure 6 – Efficiency vs. Load, Room Temperature, 60 Hz.

Percent of Full Load	Efficiency (%)	
	115 VAC	230 VAC
25	74.6	73.6
50	74.6	74.3
75	72.9	73.6
100	70.8	72.5
Average	73.2	73.5
US EISA (2007) requirement	66.1	
ENERGY STAR 2.0 requirement	69.5	

Table 1 – Efficiency Table.



9.2 Energy Efficiency Requirements

The external power supply requirements below all require meeting active mode efficiency and no-load input power limits. Minimum active mode efficiency is defined as the average efficiency of 25, 50, 75 and 100% of output current (based on the nameplate output current rating).

For adapters that are single input voltage only then the measurement is made at the rated single nominal input voltage (115 VAC or 230 VAC), for universal input adapters the measurement is made at both nominal input voltages (115 VAC and 230 VAC).

To meet the standard the measured average efficiency (or efficiencies for universal input supplies) must be greater than or equal to the efficiency specified by the standard.

The test method can be found here:

http://www.energystar.gov/ia/partners/prod_development/downloads/power_supplies/EP_SupplyEffic_TestMethod_0804.pdf

For the latest up to date information please visit the PI Green Room:

<http://www.powerint.com/greenroom/regulations.htm>



9.2.1 USA Energy Independence and Security Act 2007

This legislation mandates all single output single output adapters, including those provided with products, manufactured on or after July 1st, 2008 must meet minimum active mode efficiency and no load input power limits.

Active Mode Efficiency Standard Models

Nameplate Output (P_O)	Minimum Efficiency in Active Mode of Operation
< 1 W	$0.5 \times P_O$
≥ 1 W to ≤ 51 W	$0.09 \times \ln(P_O) + 0.5$
> 51 W	0.85

\ln = natural logarithm

No-load Energy Consumption

Nameplate Output (P_O)	Maximum Power for No-load AC-DC EPS
All	≤ 0.5 W

This requirement supersedes the legislation from individual US States (for example CEC in California).



9.2.2 ENERGY STAR EPS Version 2.0

This specification takes effect on November 1st, 2008.

Active Mode Efficiency Standard Models

Nameplate Output (P_O)	Minimum Efficiency in Active Mode of Operation
≤ 1 W	$0.48 \times P_O + 0.14$
> 1 W to ≤ 49 W	$0.0626 \times \ln(P_O) + 0.622$
> 49 W	0.87

\ln = natural logarithm

Active Mode Efficiency Low Voltage Models ($V_O < 6$ V and $I_O \geq 550$ mA)

Nameplate Output (P_O)	Minimum Efficiency in Active Mode of Operation
≤ 1 W	$0.497 \times P_O + 0.067$
> 1 W to ≤ 49 W	$0.075 \times \ln(P_O) + 0.561$
> 49 W	0.86

\ln = natural logarithm

No-load Energy Consumption (both models)

Nameplate Output (P_O)	Maximum Power for No-load AC-DC EPS
0 to < 50 W	≤ 0.3 W
≥ 50 W to ≤ 250 W	≤ 0.5 W



9.3 No-load Input Power

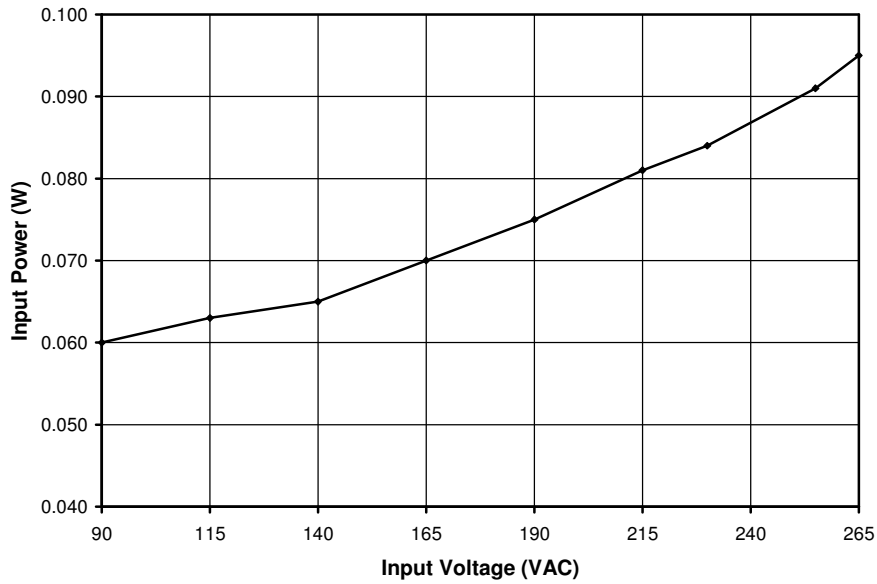

Figure 7 – Zero Load Input Power vs. Input Line Voltage, Room Temperature, 60 Hz.

9.4 Regulation

9.4.1 Load

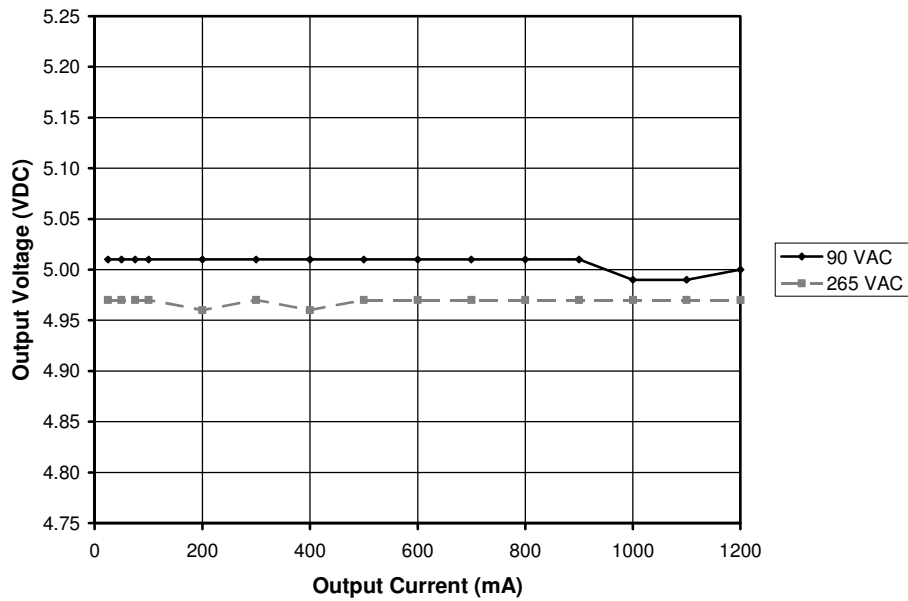

Figure 8 – Load Regulation, Room Temperature.



9.4.2 Line

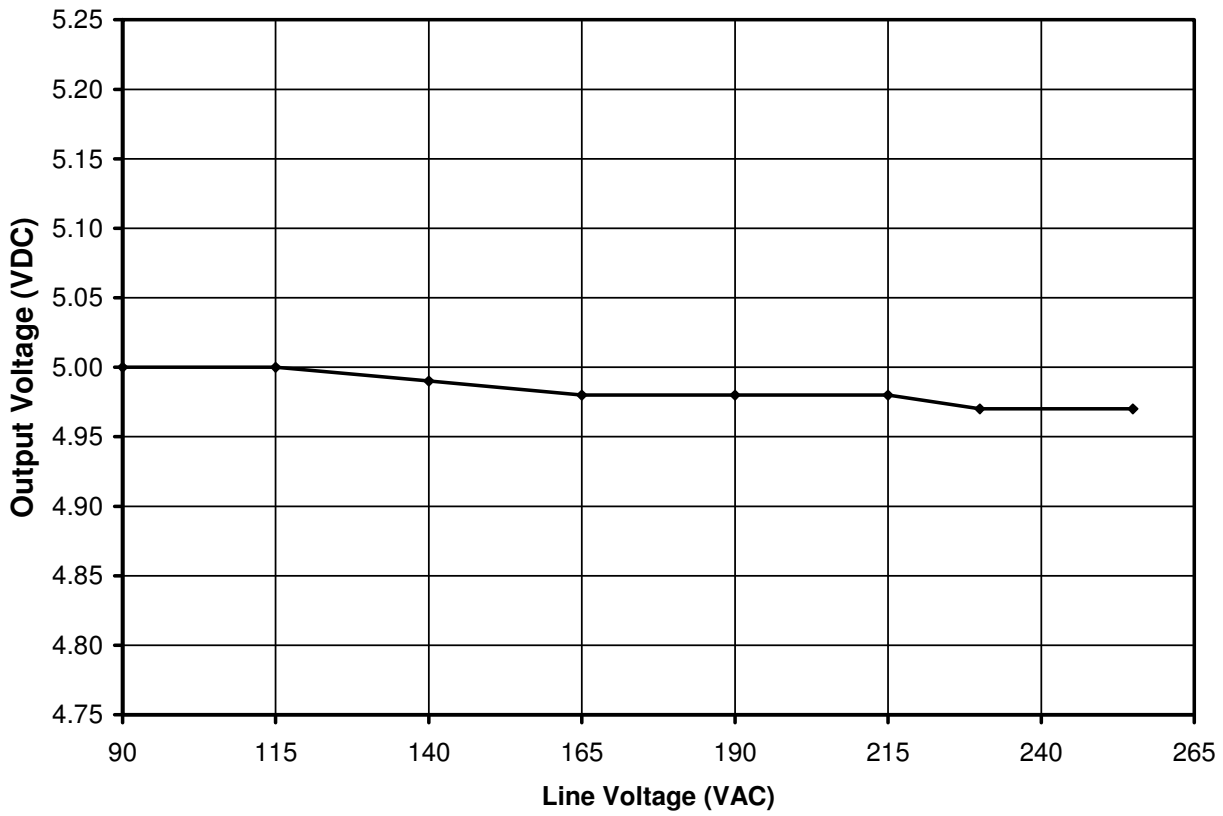

Figure 9 – Line Regulation, Room Temperature, Full Load.



10 Thermal Performance

The temperature of key components was measured to evaluate the thermal performance of the power supply. The power supply's thermal performance was measured at both low line (90 VAC) and high line (265 VAC) with line frequency of 50 Hz. The power supply was loaded to full load (1200 mA).

The power supply was placed inside a cardboard box, to minimize convective cooling, which was then placed in a thermal chamber. The ambient temperature within the box was monitored by a T-type thermocouple placed above the power supply. The temperature of the Power Integrations device, U1, was monitored by soldering a T-type thermocouple to one of the middle source pins, close to the case. The temperature of the transformer windings (T1) was monitored by gluing a T-type thermocouple, using thermally conductive epoxy, to the outermost layer of tape on the bottom of the transformer (closest to the PCB). Lastly the output diode's (D7) temperature was monitored by soldering a T-type thermocouple to the anode, near the case.

Item	Temperature (°C)	
	90 VAC / 50 Hz	265 VAC / 50 Hz
Ambient	40	40
Source Pin of PI Device (U1)	87	69
Transformer Windings (T1)	70	67
Anode of Output Diode (D7)	76	76

Table 2 – Thermal Performance of the Power Supply.



11 Waveforms

11.1 Drain Voltage and Current, Normal Operation

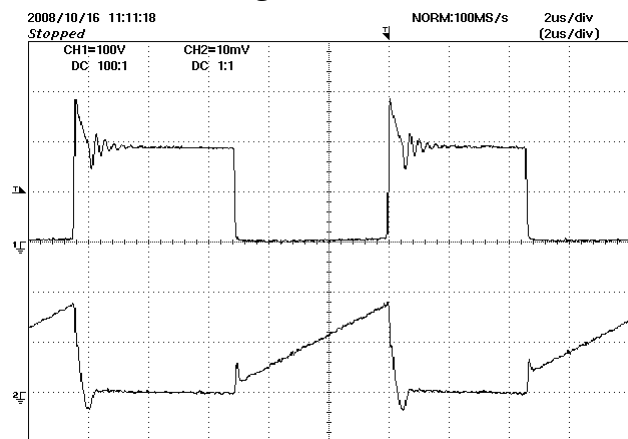

Figure 10 – 90 VAC, Full Load.
Upper: V_{DRAIN} , 100 V / div, 2 μ s / div.
Lower: I_{DRAIN} , 0.2 A / div.

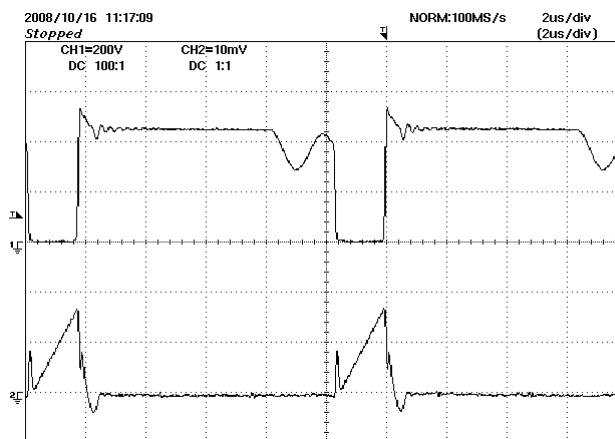

Figure 11 – 265 VAC, Full Load.
Upper: V_{DRAIN} , 200 V, 2 μ s / div.
Lower: I_{DRAIN} , 0.2 A / div.

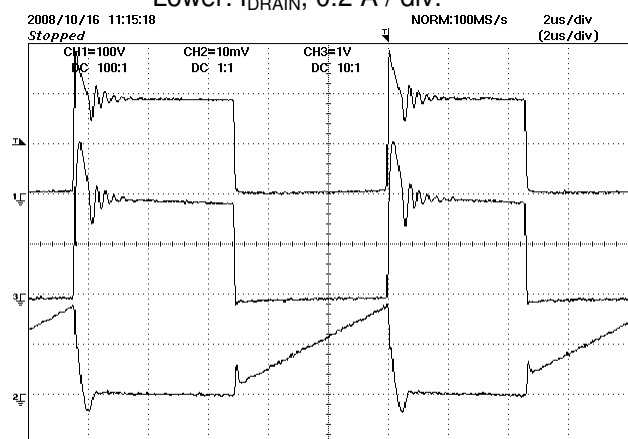

Figure 12 – 90 VAC, Full Load.
Upper: V_{DRAIN} , 100 V, 2 μ s / div.
Middle: V_{FB} , 1 V / div.
Lower: I_{DRAIN} , 0.2 A / div.

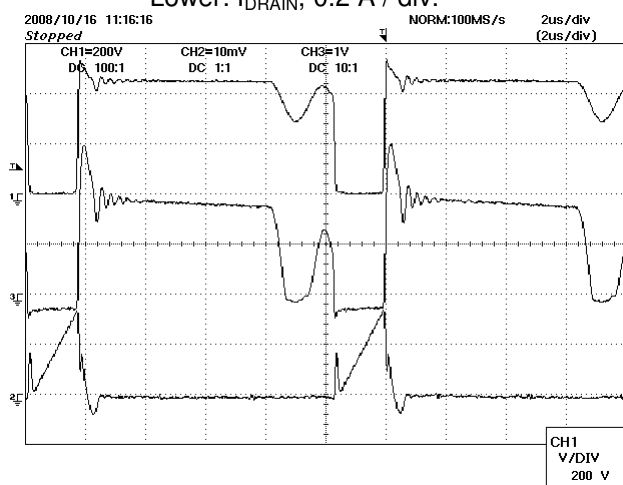

Figure 13 – 265 VAC, Full Load.
Upper: V_{DRAIN} , 200 V, 2 μ s / div.
Middle: V_{FB} , 1 V / div.
Lower: I_{DRAIN} , 0.2 A / div.



11.2 Output Voltage Start-up Profile

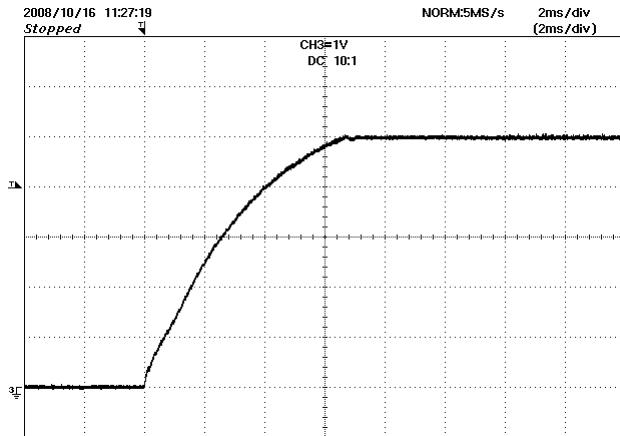

Figure 14 – Start-up Profile, 90 VAC, Full Load
1 V, 2 ms / div.

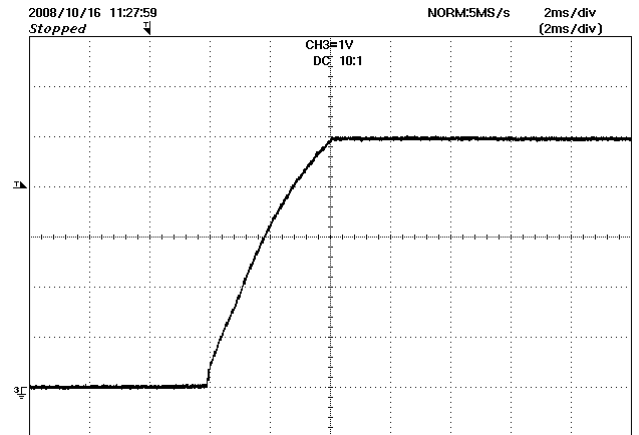

Figure 15 – Start-up Profile, 265 VAC, Full Load
1 V, 2 ms / div.

11.3 Drain Voltage and Current Start-up Profile

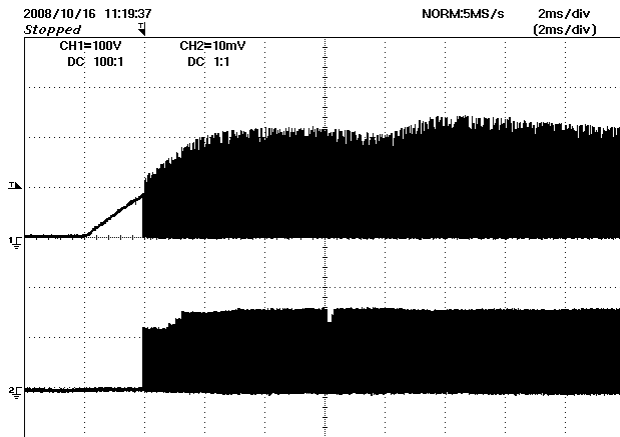

Figure 16 – 90 VAC Input and Full Load.
Upper: V_{DRAIN} , 100 V, 2 ms / div.
Lower: I_{DRAIN} , 0.2 A / div.

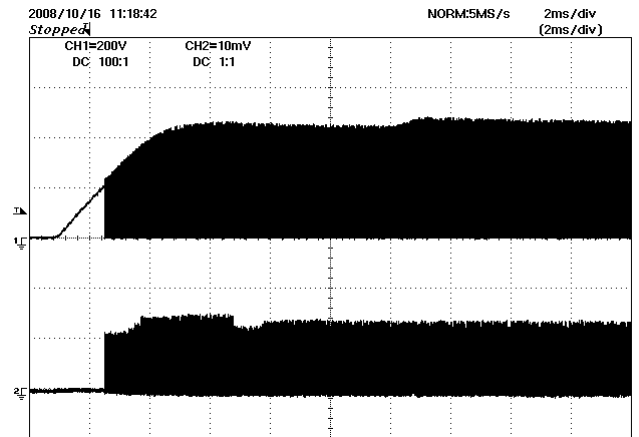

Figure 17 – 265 VAC Input and Full Load.
Upper: V_{DRAIN} , 200 V, 2 ms / div.
Lower: I_{DRAIN} , 0.2 A / div.

11.4 Load Transient Response (75% to 100% Load Step)

In the figures shown below, signal averaging was used to better enable viewing the load transient response. The oscilloscope was triggered using the load current step as a trigger source. Since the output switching and line frequency occur essentially at random with respect to the load transient, contributions to the output ripple from these sources will average out, leaving the contribution only from the load step response.



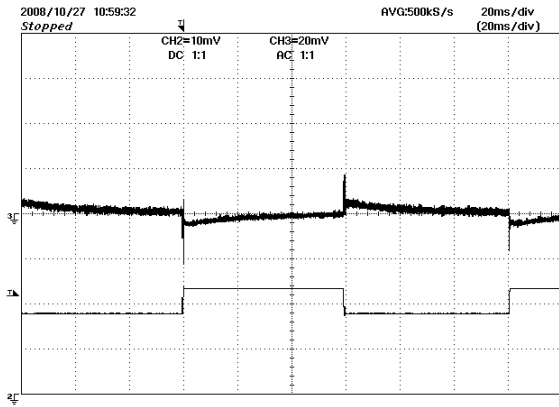

Figure 18 – Transient Response, 90 VAC
75-100-75% Load Step.
Upper: Output Voltage
10 mV, 10 ms / div.
Bottom: Load Current, 0.5 A / div.

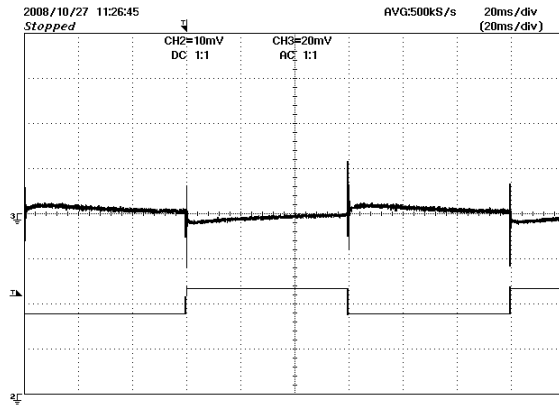

Figure 19 – Transient Response, 265 VAC
75-100-75% Load Step.
Upper: Load Current, 1 A / div.
Bottom: Output Voltage
50 mV, 2 ms / div.



11.5 Output Ripple Measurements

11.5.1 Ripple Measurement Technique

For DC output ripple measurements, use a modified oscilloscope test probe to reduce spurious signals. Details of the probe modification are provided in figures below.

Tie two capacitors in parallel across the probe tip of the 4987BA probe adapter. Use a 0.1 μF /50 V ceramic capacitor and a 1.0 μF /50 V aluminum-electrolytic capacitor. The aluminum-electrolytic capacitor is polarized, so always maintain proper polarity across DC outputs.

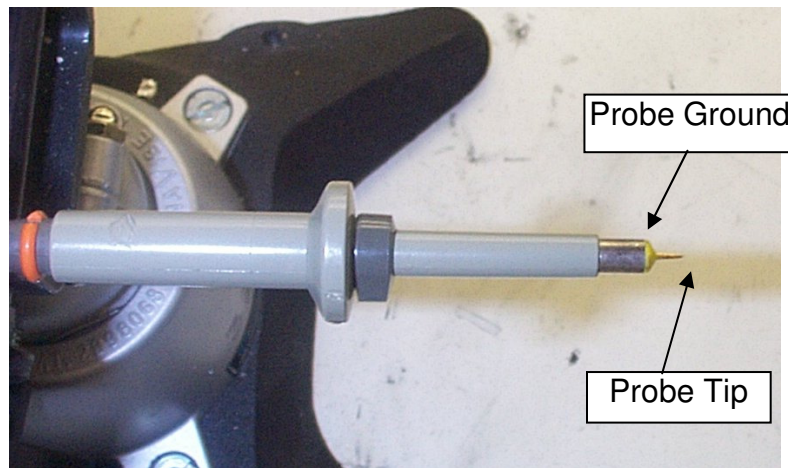

Figure 20 – Oscilloscope Probe Prepared for Ripple Measurement. (End Cap and Ground Lead Removed)



Figure 21 – Oscilloscope Probe with Probe Master (www.probemaster.com) 4987A BNC Adapter. (Modified with wires for ripple measurement, and two parallel decoupling capacitors added)

11.5.2 Measurement Results

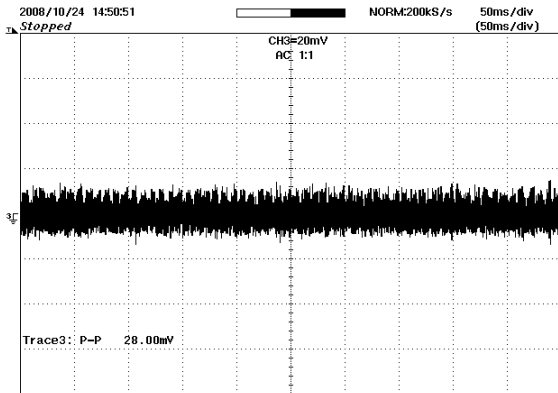

Figure 22 – Ripple, 90 VAC, Full Load.
50 ms, 20 mV / div.

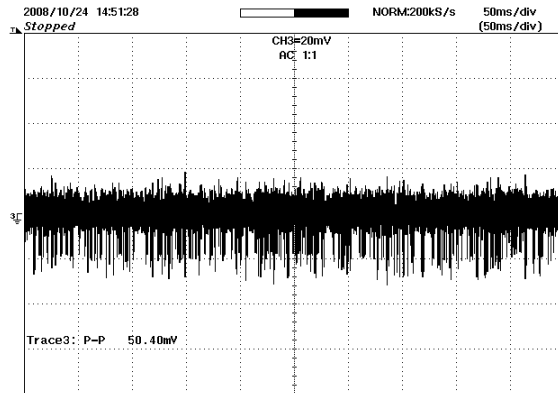

Figure 23 – 265 VAC, Full Load.
50 ms, 20 mV / div.



12 Line Surge

Differential input line 1.2/50 μ s surge testing was completed on a single test unit to IEC61000-4-5. Input voltage was set at 230 VAC / 60 Hz. Output was loaded at full load and operation was verified following each surge event.

Surge Level (V)	Input Voltage (VAC)	Injection Location	Injection Phase (°)	Test Result (10 Strikes Pass/Fail)
+500	230	L to N (2 Ω)	90	Pass
+1000	230	L to PE (12 Ω)	90	Pass
+1000	230	L to N (2 Ω)	90	Pass
+2000	230	L to PE (12 Ω)	90	Pass

Unit passes under all test conditions.



13 Conducted EMI

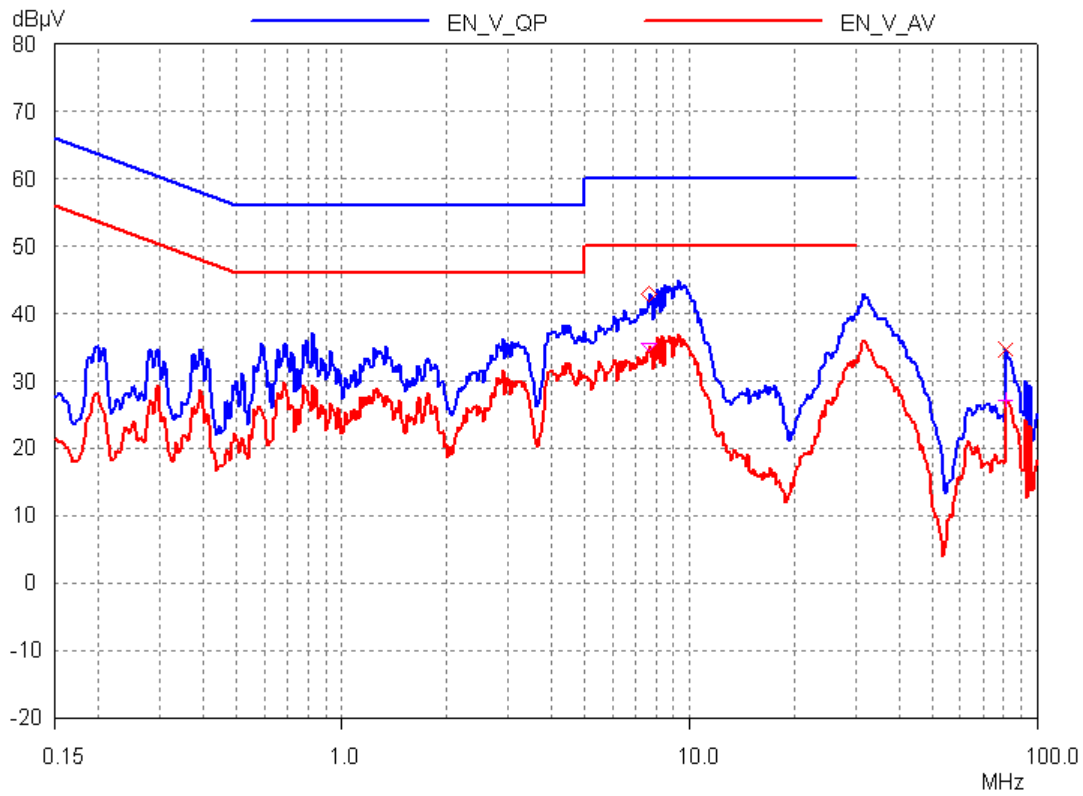

Figure 24 – Worst Case Conducted EMI, Maximum Steady State Load, 230 VAC, 60 Hz, and EN55022 B Limits, Artificial Hand.

14 Revision History

Date	Author	Revision	Description & changes	Reviewed
11-Nov-08	TS	1.5	Initial Release	SGK, PV



Notes



Notes



For the latest updates, visit our website: www.powerint.com

Power Integrations reserves the right to make changes to its products at any time to improve reliability or manufacturability. Power Integrations does not assume any liability arising from the use of any device or circuit described herein. POWER INTEGRATIONS MAKES NO WARRANTY HEREIN AND SPECIFICALLY DISCLAIMS ALL WARRANTIES INCLUDING, WITHOUT LIMITATION, THE IMPLIED WARRANTIES OF MERCHANTABILITY, FITNESS FOR A PARTICULAR PURPOSE, AND NON-INFRINGEMENT OF THIRD PARTY RIGHTS.

PATENT INFORMATION

The products and applications illustrated herein (including transformer construction and circuits external to the products) may be covered by one or more U.S. and foreign patents, or potentially by pending U.S. and foreign patent applications assigned to Power Integrations. A complete list of Power Integrations' patents may be found at www.powerint.com. Power Integrations grants its customers a license under certain patent rights as set forth at <http://www.powerint.com/ip.htm>.

The PI Logo, TOPSwitch, TinySwitch, LinkSwitch, DPA-Switch, PeakSwitch, EcoSmart, Clampless, E-Shield, Filterfuse, StackFET, PI Expert and PI FACTS are trademarks of Power Integrations, Inc. Other trademarks are property of their respective companies. ©Copyright 2008 Power Integrations, Inc.

Power Integrations Worldwide Sales Support Locations

WORLD HEADQUARTERS

5245 Hellyer Avenue
San Jose, CA 95138, USA.
Main: +1-408-414-9200
Customer Service:
Phone: +1-408-414-9665
Fax: +1-408-414-9765
e-mail: usasales@powerint.com

GERMANY

Rueckertstrasse 3
D-80336, Munich
Germany
Phone: +49-89-5527-3911
Fax: +49-89-5527-3920
e-mail: eurosales@powerint.com

JAPAN

Kosei Dai-3 Bldg.,
2-12-11, Shin-Yokohama,
Kohoku-ku, Yokohama-shi,
Kanagawa 222-0033
Phone: +81-45-471-1021
Fax: +81-45-471-3717
e-mail:
japansales@powerint.com

TAIWAN

5F, No. 318, Nei Hu Rd., Sec. 1
Nei Hu Dist.
Taipei, Taiwan 114, R.O.C.
Phone: +886-2-2659-4570
Fax: +886-2-2659-4550
e-mail:
taiwansales@powerint.com

CHINA (SHANGHAI)

Rm 1601/1610, Tower 1,
Kerry Everbright City
No. 218 Tianmu Road West,
Shanghai, P.R.C. 200070
Phone: +86-21-6354-6323
Fax: +86-21-6354-6325
e-mail:
chinasales@powerint.com

INDIA

#1, 14th Main Road
Vasanthanagar
Bangalore-560052 India
Phone: +91-80-41138020
Fax: +91-80-41138023
e-mail: indiasales@powerint.com

KOREA

RM 602, 6FL
Korea City Air Terminal B/D,
159-6
Samsung-Dong, Kangnam-
Gu,
Seoul, 135-728, Korea
Phone: +82-2-2016-6610
Fax: +82-2-2016-6630
e-mail:
koreasales@powerint.com

UNITED KINGDOM

1st Floor, St. James's House
East Street, Farnham
Surrey, GU9 7TJ
United Kingdom
Phone: +44 (0) 1252-730-141
Fax: +44 (0) 1252-727-689
e-mail:
eurosales@powerint.com

CHINA (SHENZHEN)

Rm A, B & C 4th Floor, Block C,
Electronics Science and
Technology Building, 2070
Shennan Zhong Rd,
Shenzhen, Guangdong,
China, 518031
Phone: +86-755-8379-3243
Fax: +86-755-8379-5828
e-mail:
chinasales@powerint.com

ITALY

Via De Amicis 2
20091 Bresso MI – Italy
Phone: +39-028-928-6000
Fax: +39-028-928-6009
e-mail: eurosales@powerint.com

SINGAPORE

51 Newton Road,
#15-08/10 Goldhill Plaza,
Singapore, 308900
Phone: +65-6358-2160
Fax: +65-6358-2015
e-mail:
singaporeales@powerint.com

APPLICATIONS HOTLINE

World Wide +1-408-414-9660

APPLICATIONS FAX

World Wide +1-408-414-9760

