

CATALOG NUMBER	MATERIAL NUMBER	CONDUIT SIZE	N.P.T. FITTING SIZE	LENGTH "M"	DIAMETER "A" REF.	LENGTH "B" REF.	LENGTH "C" REF.	LENGTH "D" REF.	PRODUCT SELECTION NUMBER	UL LISTED	CSA APRVD
37100-90	-----	3/8"	3/8"	9.00±1.00 / 228.6±25.4	1.2 / 30	1.16 / 29.5	.59 / 15.0	1.25 / 31.8	STNM-90038W	N O	N O
37101-90	1300960070	1/2"	1/2"	10.00±1.00 / 254.0±25.4	1.4 / 36	1.31 / 33.3	.59 / 15.0	1.28 / 32.5	STNM-90050W		
37102-90	1300960072	3/4"	3/4"	11.50±1.00 / 292.1±25.4	1.6 / 41	1.63 / 41.4	.59 / 15.0	1.44 / 36.6	STNM-90075W		
37103-90	1300960074	1"	1"	12.00±1.00 / 304.8±25.4	1.9 / 48	1.94 / 49.3	.72 / 18.3	1.75 / 44.5	STNM-90100W		
37104-90	1300960076	1-1/4"	1-1/4"	17.00±1.50 / 431.8±38.1	2.4 / 61	2.41 / 61.2	.75 / 19.1	1.97 / 50.0	STNM-90125W		
37105-90	1300960078	1-1/2"	1-1/2"	21.50±2.00 / 546.1±50.8	2.9 / 74	2.78 / 70.6	.75 / 19.1	2.25 / 57.2	STNM-90150W		
37106-90	-----	2"	2"	24.00±2.00 / 609.6±50.8	3.5 / 89	3.38 / 85.9	.75 / 19.1	2.53 / 64.3	STNM-90200W		

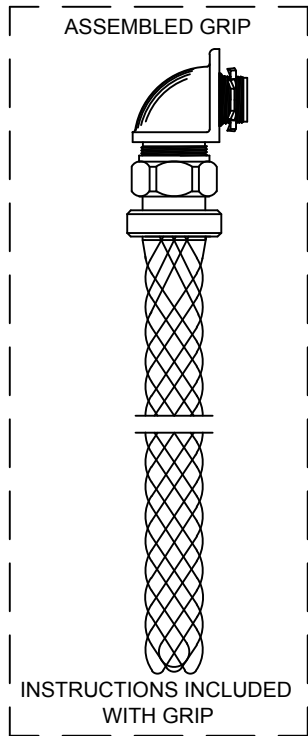
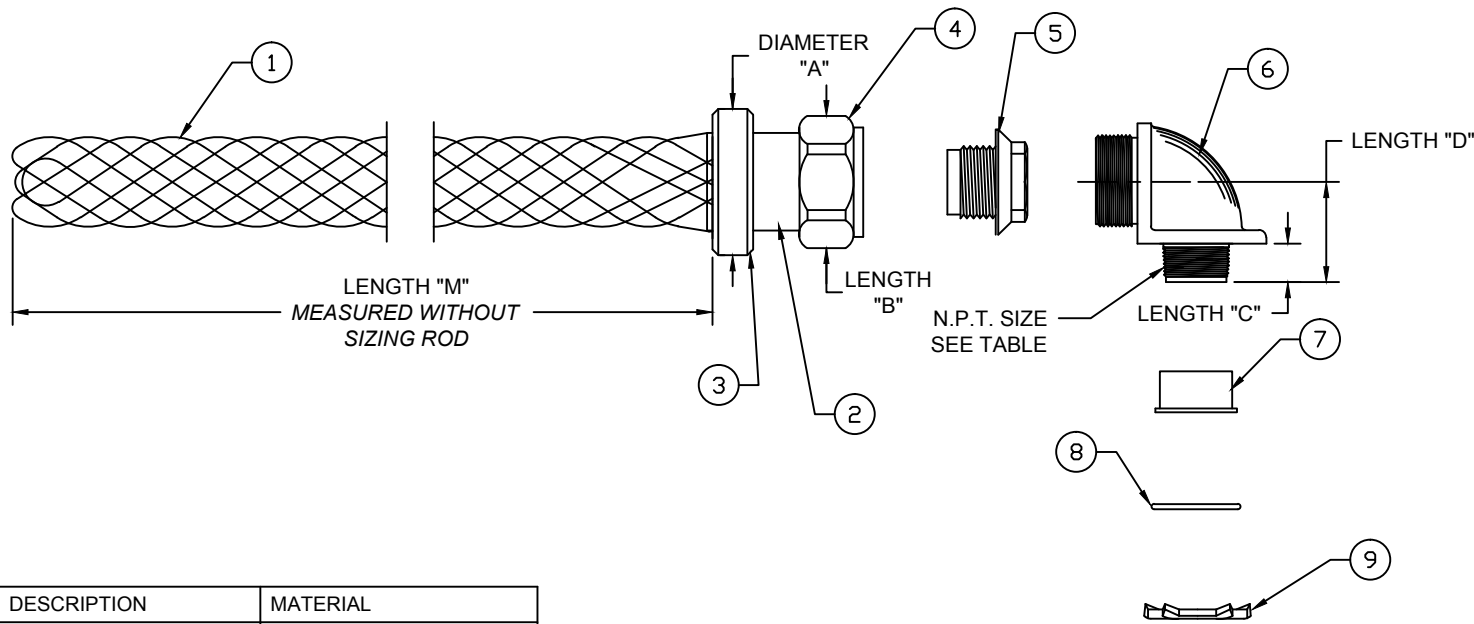

ITEM	DESCRIPTION	MATERIAL
1	WIRE MESH	STAINLESS STEEL
2	INNER RING	ZINC PLATED STEEL
3	OUTER RING	ALUMINUM
4	COMPRESSION NUT	ZINC PLATED STEEL OR ZINC PLATED CAST IRON
5	FERRULE	NYLON
6	THREADED BODY	ZINC PLATED CAST IRON
7	THROAT INSULATION	PLASTIC
8	O'RING	NEOPRENE
9	LOCK NUT	ZINC PLATED STEEL

RELEASE SALES DRAWING EC NO: IPC2015-0574 DRWN: HRUIZ01 2014/09/24 CHKD: HKNEELAN 2014/09/24 APPR: JFMURPHY 2015/04/27	DESCRIPTION REV A	QUALITY SYMBOLS $\nabla=0$ $\nabla C=0$	GENERAL TOLERANCES (UNLESS SPECIFIED) <table border="1"> <tr> <th></th> <th>mm</th> <th>INCH</th> </tr> <tr> <td>4 PLACES</td> <td>±---</td> <td>±---</td> </tr> <tr> <td>3 PLACES</td> <td>±---</td> <td>±.005</td> </tr> <tr> <td>2 PLACES</td> <td>±.13</td> <td>±.010</td> </tr> <tr> <td>1 PLACE</td> <td>±.25</td> <td>±.020</td> </tr> </table>		mm	INCH	4 PLACES	±---	±---	3 PLACES	±---	±.005	2 PLACES	±.13	±.010	1 PLACE	±.25	±.020	DIMENSION STYLE INCH/MM DRAWN BY DATE HRUIZ01 2014/09/24 CHECKED BY DATE HKNEELAN 2014/09/24 APPROVED BY DATE JFMURPHY 2015/04/27	SCALE NTS DESIGN UNITS INCH THIRD ANGLE PROJECTION	TITLE STRAIN RELIEF L.T. NON-METALLIC TYPE A CONDUIT RIGHT ANGLE MALE
			mm	INCH																	
		4 PLACES	±---	±---																	
		3 PLACES	±---	±.005																	
2 PLACES	±.13	±.010																			
1 PLACE	±.25	±.020																			
DRAFT WHERE APPLICABLE MUST REMAIN WITHIN DIMENSIONS			MATERIAL NO. SEE TABLE	DOCUMENT NO. SD-130096-105	SHEET NO. 1 OF 1																
SIZE A			THIS DRAWING CONTAINS INFORMATION THAT IS PROPRIETARY TO MOLEX INCORPORATED AND SHOULD NOT BE USED WITHOUT WRITTEN PERMISSION																		

6 5 4 3 2 1

E

E

D

D

C

C

B

B

A

A

6 5 4 3 2 1