

NOTES

- ① 材料及び仕上げ(めっき仕様) : TABLE 1 参照  
MATERIAL AND FINISHES : SEE TABLE 1
- 2. 製品仕様書 : 5011890001-PS 000  
PRODUCT SPECIFICATION:
- 3. 梱包形態 : SEE SHEET 3  
PACKAGING INFORMATION:
- ④ 嵌合相手 : 501189 シリーズ  
MATES WITH:501189 SERIES
- 5. アプリケーション仕様書(コネクタ取扱い説明書) : 5011890000-AS A00(JAPANESE)/A01(ENGLISH)  
APPLICATION SPECIFICATION(CONNECTOR MANUAL):
- 6. ソルダーピン及びネイルの平坦度:0.1 MAX.  
SOLDER PIN AND NAIL COPLANARITY: 0.1 MAX.
- ⑦ 極数/2=偶数に適用  
APPLICABLE FOR CIRCUIT SIZE/2=EVEN
- ⑧ 凹形状はキャビティにより、反対側面に存在します。  
THE CONCAVE AREA TO BE SET ON THE REVERSE SIDE DEPENDING ON THE MOLDING CAVITY.
- 9. 本製品は複数の金めっき厚を展開しております。その他の金めっき厚は以下の図面を御参照下さい。  
THIS PRODUCT EXIST MULTIPLE GOLD PLATING.  
PLEASE REFER TO THE FOLLOWING DRAWING FOR OTHER GOLD PLATING THICKNESS.

GOLD PLATING THICKNESS [micro-meter MIN.]	SERIES No.	DRAWING No.
0.1	501571	5015710000-SD PSD 000
0.38	203566	2035660000-SD PSD 000

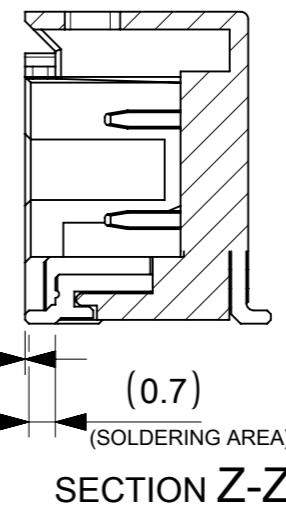
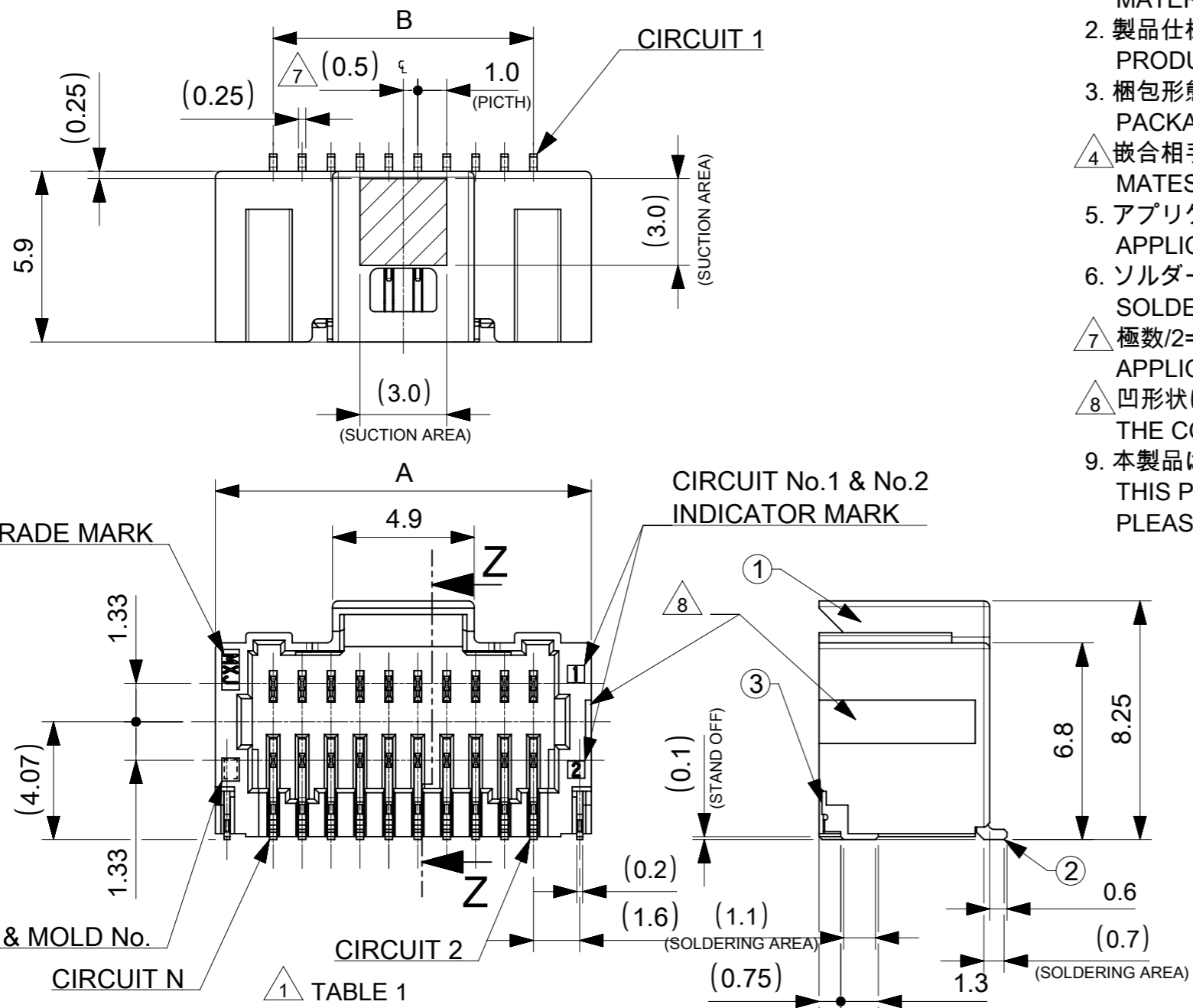

B	A	極数 CIRCUIT SIZE
24.0	28.0	50
19.0	23.0	40
14.0	18.0	30
9.0	13.0	20

番号 NO.	部品 PART	材質 MATERIAL	
①	ウエハー WAFER	ポリアミド(PA), UL94V-0, 色 : SEE SHEET 5 POLYAMIDE(PA), UL94V-0, COLOR : SEE SHEET 5	
②	ソルダーピン SOLDER PIN	リン青銅 PHOSPHOR BRONZE	
		接点部 CONTACT AREA	金めっき : 0.76 MICRO-METER MIN. GOLD PLATING
		テール部 TAIL AREA	金めっき : 0.05 MICRO-METER MIN. GOLD PLATING
	下地めっき UNDER PLATING	ニッケルめっき : 1.27 MICRO-METER MIN. NICKEL	
③	ネイル NAIL	黄銅 BRASS	
		テール部 TAIL AREA	錫めっき : 1.0 MICRO-METER MIN. MATTE TIN PLATING
		下地めっき UNDER PLATING	ニッケルめっき : 1.0 MICRO-METER MIN. NICKEL

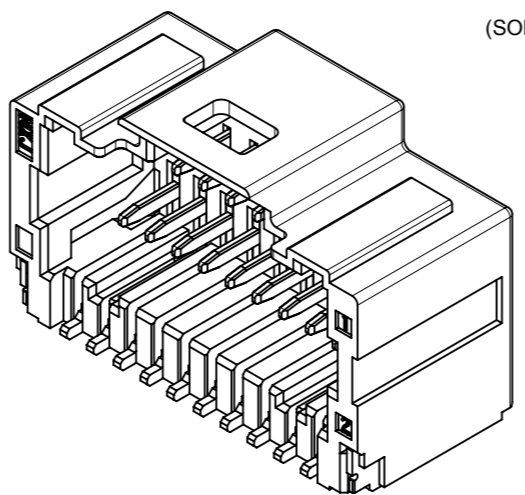

THIS DRAWING CONTAINS INFORMATION THAT IS PROPRIETARY TO MOLEX ELECTRONIC TECHNOLOGIES, LLC AND SHOULD NOT BE USED WITHOUT WRITTEN PERMISSION

DIMENSION UNITS mm	SCALE NTS	CURRENT REV DESC:	<b>molex</b>		
GENERAL TOLERANCES (UNLESS SPECIFIED)	ANGULAR TOL ± 3.0°	EC NO: 614725			
4 PLACES ± 0.2	DRWN: AISHIKAWA 2019/03/29	CHK'D: AIDA 2019/04/03	PRODUCT CUSTOMER DRAWING		
3 PLACES ± 0.2	APPR: KOMURAKAMI 2019/04/03	INITIAL REVISION:	DOCUMENT NUMBER		
2 PLACES ± 0.2	DRWN: AISHIKAWA 2019/03/29	APPR: KOMURAKAMI 2019/04/03	DOC TYPE DOC PART REVISION		
1 PLACE ± 0.2	0 PLACES ± 0.2		2035670000-SD PSD 000 A		
DRAFT WHERE APPLICABLE MUST REMAIN WITHIN DIMENSIONS	THIRD ANGLE PROJECTION	DRAWING	SERIES	MATERIAL NUMBER	CUSTOMER
		A3-SIZE	203567	SEE SHEET 5	

SHEET NUMBER: 1 OF 5

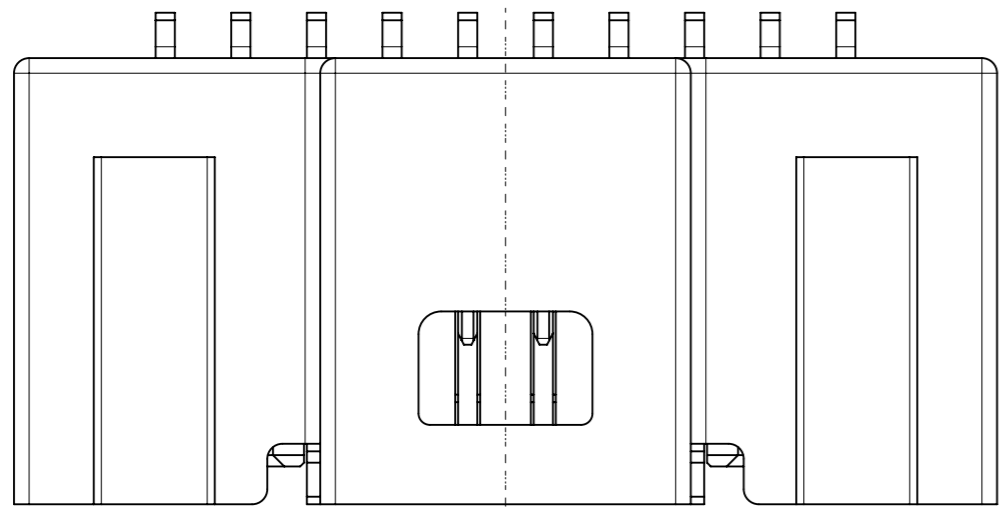

製品レイアウト  
PRODUCT LAYOUT

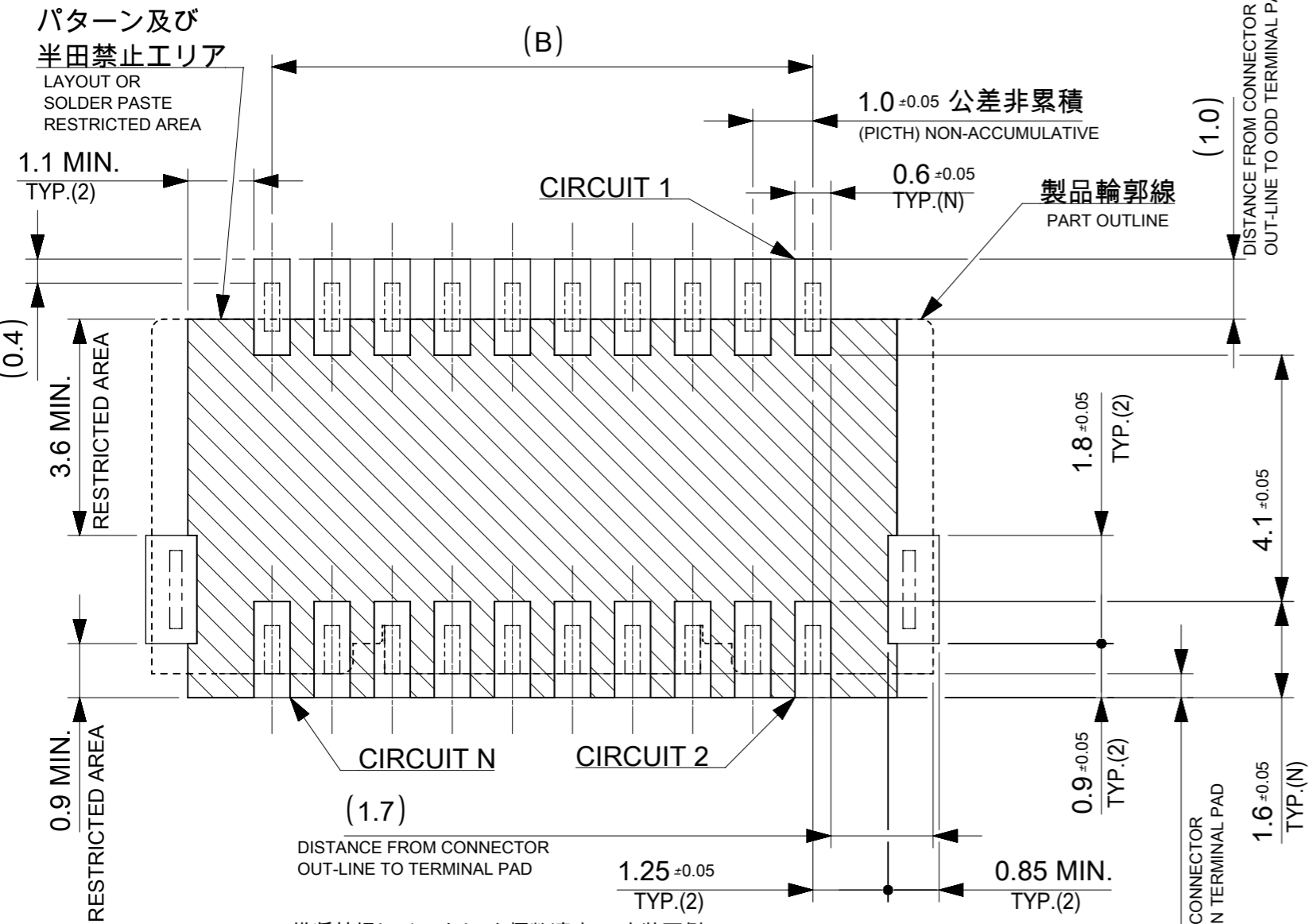

推奨基板レイアウト(全極数適応) : 実装面側  
(参考 : 基板厚 1.0mm, メタルマスク厚さ 0.12mm, マスク開口率100%)

POLARIZED RECOMMENDED PCB LAYOUT(APPLY TO ALL CIRCUIT) : COMPONENT SIDE  
(REFERENCE: PCB THICKNESS 1.0mm, STENCIL THICKNESS 0.12mm, APERTURE RATIO 100%)

:パターン禁止エリア  
RESTRICTED AREA  
NO PCB COMPONENTS ALLOWED

△4 嵌合相手:501189シリーズ  
MATE WITH : 501189 SERIES

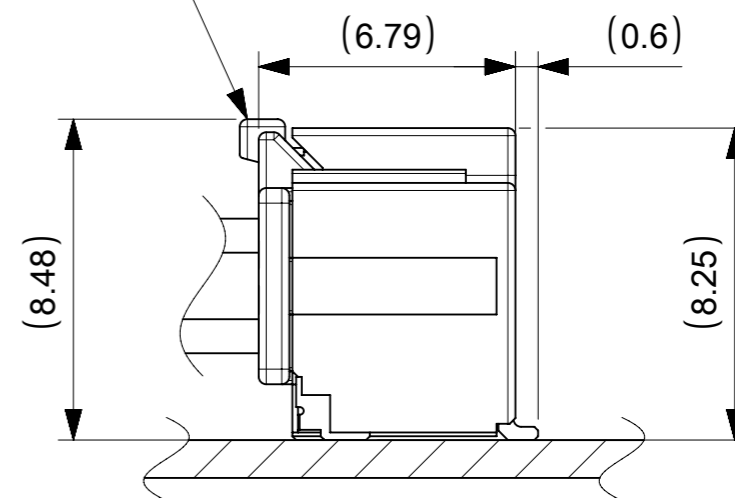
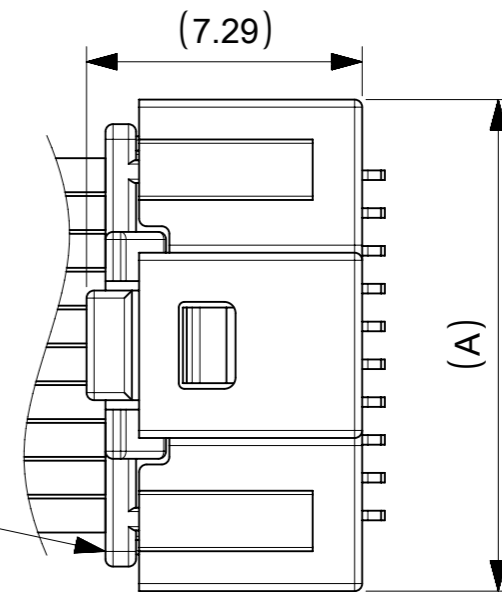

嵌合図  
MATED CONNECTORS

THIS DRAWING CONTAINS INFORMATION THAT IS PROPRIETARY TO MOLEX ELECTRONIC TECHNOLOGIES, LLC AND SHOULD NOT BE USED WITHOUT WRITTEN PERMISSION		CURRENT REV DESC:		<b>molex</b>		
DIMENSION UNITS	SCALE					
mm	NTS			PICO-CLASP 1.0 W/B DUAL ROW RA SMT GOLD PLATING 0.76 MICRO-METER		
GENERAL TOLERANCES (UNLESS SPECIFIED)		EC NO: 614725		DOCUMENT NUMBER		
ANGULAR TOL	± 3.0 °	DRWN: AISHIKAWA 2019/03/29		2035670000-SD		
4 PLACES	± 0.2	CHK'D: AIDA 2019/04/03		DOC TYPE	DOC PART	
3 PLACES	± 0.2	APPR: KOMURAKAMI 2019/04/03		PSD	000	
2 PLACES	± 0.2	INITIAL REVISION:		REVISION		
1 PLACE	± 0.2	DRWN: AISHIKAWA 2019/03/29		A		
0 PLACES	± 0.2	APPR: KOMURAKAMI 2019/04/03				
DRAFT WHERE APPLICABLE MUST REMAIN WITHIN DIMENSIONS		THIRD ANGLE PROJECTION	DRAWING	SERIES	MATERIAL NUMBER	CUSTOMER
			A3-SIZE	203567	SEE SHEET 5	
DOCUMENT STATUS		P1	RELEASE DATE	2019/04/03	09:48:57	SHEET NUMBER
						2 OF 5

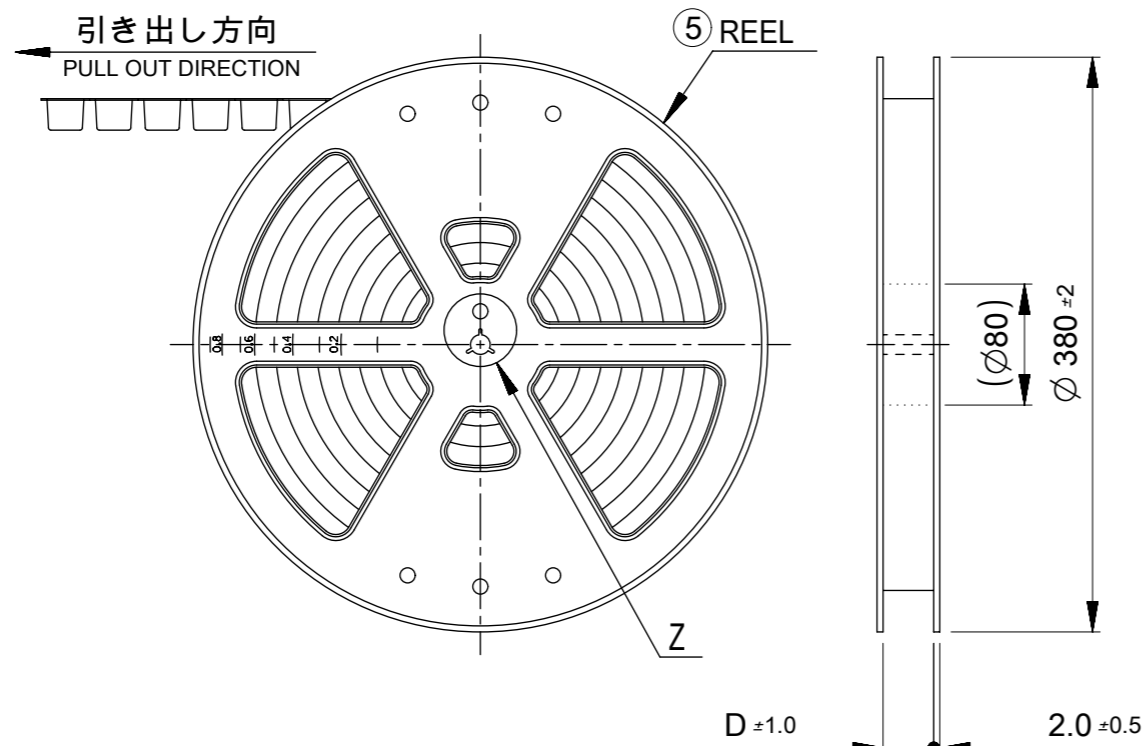

NOTES

- 10. 梱包数量:800個/リール  
NUMBER OF CONNECTORS : 800 PIECES/REEL
- 11. リードテープ長さ  
LEAD TAPE LENGTH

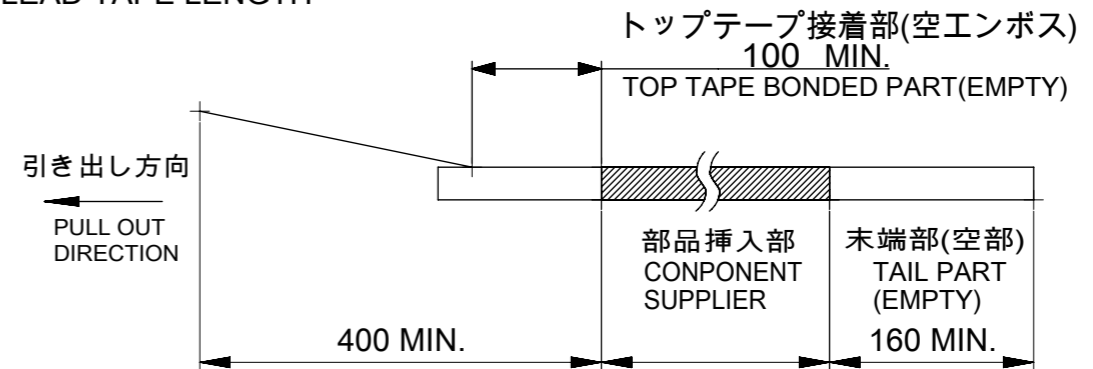

- 12. トップテープの剥離強度はIEC60286-3に準拠。  
TOP TAPE PEELING FORCE IS DEFINED BY IEC60286-3.
- 13. 梱包仕様書 : 2035679200 PS 200  
PACKAGE SPECIFICATION:
- 14. 発注番号 : SHEET 5 参照  
ORDER No. : PLEASE REFER TO SHEET 5 FOR PRODUCT LIST.

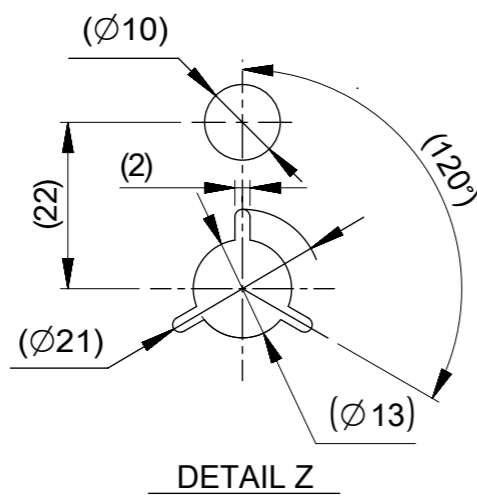

203567

\*\* \*\* \*

極数 CIRCUIT SIZE	ハウジングカラー HOUSING COLOR	製品識別番号 IDENTIFICATION NUMBER
	0:NATURAL(BEIGE)	7:EMBOSSED PACKAGE

45.5	50
	40
33.5	30
25.5	20
D	極数 CIRCUIT SIZE

番号 NO.	部品 PART	材質 MATERIAL
⑤	リール REEL	ポリスチレン(PS) <リサイクル材を含む> POLYSTYRENE(PS) <RECYCLE MATERIAL CONTAINED>
DOCUMENT STATUS	P1	RELEASE DATE 2019/04/03 09:48:57

THIS DRAWING CONTAINS INFORMATION THAT IS PROPRIETARY TO MOLEX ELECTRONIC TECHNOLOGIES, LLC AND SHOULD NOT BE USED WITHOUT WRITTEN PERMISSION		CURRENT REV DESC:		<b>molex</b>	
DIMENSION UNITS mm	SCALE NTS	EC NO: 614725 DRWN: AISHIKAWA 2019/03/29 CHK'D: AIDA 2019/04/03 APPR: KOMURAKAMI 2019/04/03			
GENERAL TOLERANCES (UNLESS SPECIFIED)		INITIAL REVISION:		DOCUMENT NUMBER	
ANGULAR TOL	± 3.0 °	DRWN: AISHIKAWA 2019/03/29 APPR: KOMURAKAMI 2019/04/03		2035670000-SD	
4 PLACES	± 0.2	DRAWING		DOC TYPE	DOC PART
3 PLACES	± 0.2	A3-SIZE		PSD	000
2 PLACES	± 0.2	SERIES		REVISION	
1 PLACE	± 0.2	203567		A	
0 PLACES	± 0.2	MATERIAL NUMBER		SHEET NUMBER	
DRAFT WHERE APPLICABLE MUST REMAIN WITHIN DIMENSIONS		THIRD ANGLE PROJECTION		CUSTOMER	
		SEE SHEET 5		3 OF 5	

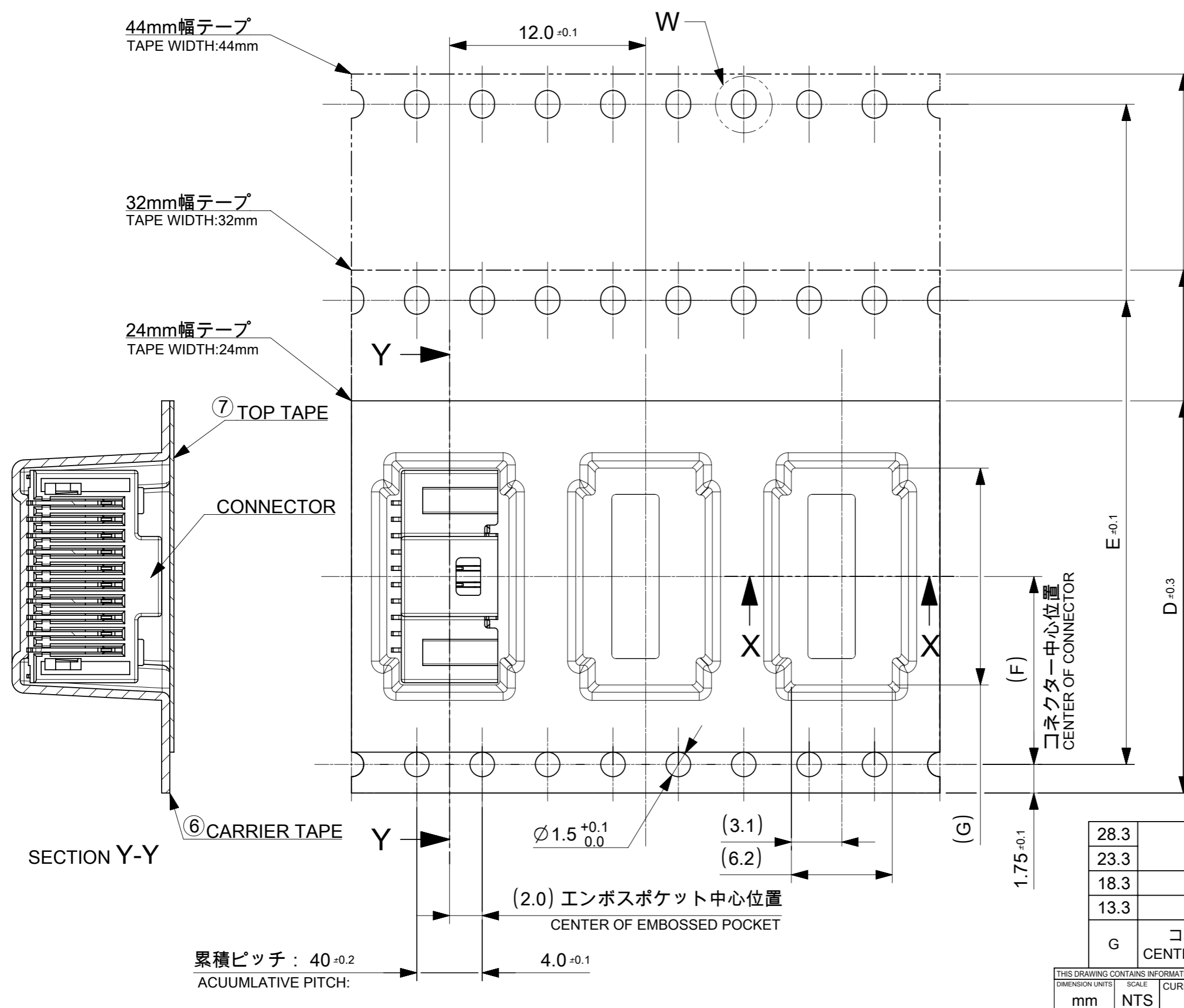

28.3				50
23.3	20.2	40.4	44.0	40
18.3	14.2	28.4	32.0	30
13.3	11.5	-	24.0	20
G	コネクタ中心位置 F CENTER OF CONNECTOR	E	エンボステープ幅 D WIDTH OF TAPE	極数 CIRCUIT SIZE

THIS DRAWING CONTAINS INFORMATION THAT IS PROPRIETARY TO MOLEX ELECTRONIC TECHNOLOGIES, LLC AND SHOULD NOT BE USED WITHOUT WRITTEN PERMISSION		CURRENT REV DESC:		<b>molex</b>	
DIMENSION UNITS	SCALE				
mm	NTS			PICO-CLASP 1.0 W/B DUAL ROW RA SMT GOLD PLATING 0.76 MICRO-METER	
GENERAL TOLERANCES (UNLESS SPECIFIED)		EC NO: 614725		DOCUMENT NUMBER	
ANGULAR TOL	± 3.0°	DRWN: AISHIKAWA 2019/03/29		2035670000-SD	
4 PLACES	± 0.2	CHK'D: AIDA 2019/04/03		DOC TYPE	DOC PART
3 PLACES	± 0.2	APPR: KOMURAKAMI 2019/04/03		PSD	000
2 PLACES	± 0.2	INITIAL REVISION:		REVISION	A
1 PLACE	± 0.2	DRWN: AISHIKAWA 2019/03/29		CUSTOMER	
0 PLACES	± 0.2	APPR: KOMURAKAMI 2019/04/03		SEE SHEET 5	
DRAFT WHERE APPLICABLE MUST REMAIN WITHIN DIMENSIONS		THIRD ANGLE PROJECTION	DRAWING	SERIES	MATERIAL NUMBER
			A3-SIZE	203567	SEE SHEET 5
		SHEET NUMBER		4 OF 5	

番号 NO.	部品 PART	材質 MATERIAL
⑥	キャリアテープ CARRIER TAPE	ポリプロピレン(PP)、その他 POLYPROPYLEN(PP), etc
⑦	トップテープ TOP TAPE	ポリエチレン(PE)、その他 POLYETHYLENE(PE), etc

DOCUMENT STATUS	P1	RELEASE DATE	2019/04/03	09:48:57
-----------------	----	--------------	------------	----------

9 8 7 6 5 4 3 2 1

E

E

D

D

C

C

B

B

A

A

△14 製品一覧 PRODUCT LIST

HOUSING COLOR	
NATURAL(BEIGE)	
203567 5007	50
203567 4007	40
203567 3007	30
203567 2007	20
発注番号 ORDER No.	極数
梱包形態 : エンボスリール PACKAGE:EMBOSSED REEL	CIRCUIT SIZE

THIS DRAWING CONTAINS INFORMATION THAT IS PROPRIETARY TO MOLEX ELECTRONIC TECHNOLOGIES, LLC AND SHOULD NOT BE USED WITHOUT WRITTEN PERMISSION										
DIMENSION UNITS	SCALE	CURRENT REV DESC:					<b>molex</b>			
mm	NTS									
GENERAL TOLERANCES (UNLESS SPECIFIED)		EC NO: 614725					PICO-CLASP 1.0 W/B			
ANGULAR TOL	± 3.0 °	DRWN: AISHIKAWA 2019/03/29					DUAL ROW RA SMT GOLD PLATING			
4 PLACES	± 0.2	CHK'D: AIDA 2019/04/03					0.76 MICRO-METER			
3 PLACES	± 0.2	APPR: KOMURAKAMI 2019/04/03					PRODUCT CUSTOMER DRAWING			
2 PLACES	± 0.2	INITIAL REVISION:					DOCUMENT NUMBER			
1 PLACE	± 0.2	DRWN: AISHIKAWA 2019/03/29					2035670000-SD			
0 PLACES	± 0.2	APPR: KOMURAKAMI 2019/04/03					PSD 000 A			
DRAFT WHERE APPLICABLE MUST REMAIN WITHIN DIMENSIONS		THIRD ANGLE PROJECTION	DRAWING	SERIES	MATERIAL NUMBER	CUSTOMER		SHEET NUMBER		
			A3-SIZE	203567	SEE SHEET 5			5 OF 5		

DOCUMENT STATUS	P1	RELEASE DATE	2019/04/03	09:48:57
-----------------	----	--------------	------------	----------

9 8 7 6 5 4 3 2 1

FORMAT: master-ib-prod-A3  
REVISION: 11  
DATE: 2018/01/18