

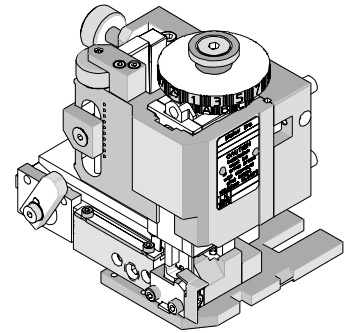

FineAdjust Applicator Specification Sheet Part No. 63900-6700



FEATURES

- Quick punch removal with the push of a button for fast and easy tooling change
- Applicator designed to industry standard mounting and shut height 135.80mm (5.346")
- Quick set-up time; plus the crimp height, track and feed adjustments can be set without removing the applicator from the press
- Fine adjustment allows users to achieve target with little effort by adjusting in increments of .015mm (.0006") for conductor crimp height and .063mm (.0025") for insulation height
- Independent adjustment rings allow users to quickly adjust the conductor or insulation crimp height without affecting each other
- Directly adapts to most automatic wire processing machines

SCOPE

Products: Mini-Fit Plus Crimp Terminal 14 AWG.

Terminal Series No.	Terminal Order No.	Wire Size		Insulation Diameter		Strip Length	
		AWG	mm ²	mm	In.	mm	In.
45750	45750-5111	14	2.08	3.00-3.10	.118-.122	3.60-4.10	.142-.161
⚠ Wire specification: UL-AWM-2586 two conductor braid shielded cable with inner conductors made to UL10012 wires 14 AWG-41 strands. (Ref: EIS wire & cable Part No. 80214021019).							

DEFINITION OF TERMS

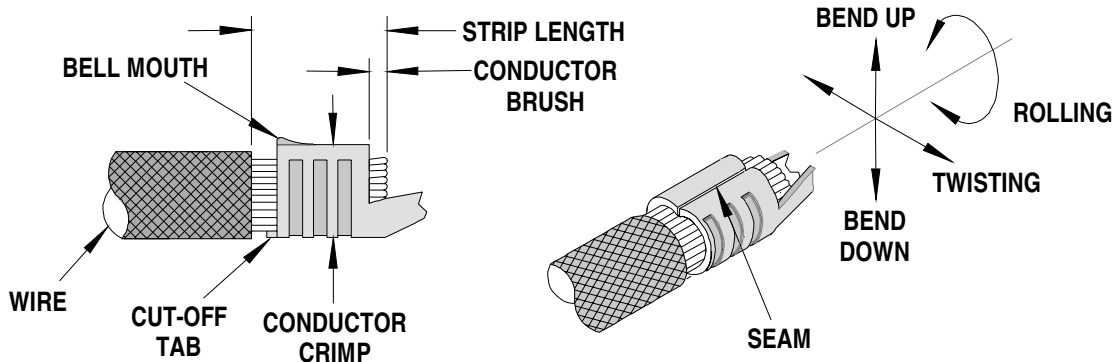

The above terminal drawing is a generic terminal representation. It is not an image of a terminal listed in the scope.

CRIMP SPECIFICATION

Terminal Series No.	Bell mouth		Cut-off Tab Maximum		Conductor Brush	
	mm	In.	mm	In.	mm	In.
45750	0.20-0.50	.008-.020	0.30	.012	1.50-2.00	.059-.079

Terminal Series No.	Bend up	Bend down	Twist	Roll	Punch Width (Ref) Conductor		Seam Seam shall not be open And no wire allowed out of the crimping area
	Degree		Degree		mm	In.	
45750	5	2	5	15	2.30	.091	

After crimping, the crimp profiles should measure the following:

Terminal Series No.	Wire Size		Conductor				Pull Force Minimum	
			Crimp Height		Crimp Width (Ref)			
	AWG	mm ²	mm	In.	mm	In.	N	Lb.
45750	14	2.08	1.40-1.50	.055-.059	2.35	.093	68.4	15.4

 Tool Qualification Notes:

1. Pull Force should be measured with no influence from the insulation crimp.
2. The above specifications are guidelines to an optimum crimp.

PARTS LIST

FineAdjust Applicator 63900-6700				
Item	Order No	Engineering No.	Description	Quantity
Perishable Tooling				
	63900-6770	63900-6770	Tool Kit (All "Y" Items)	REF
1	63457-0039	63457-0039	Conductor Punch	1 Y
2	63445-2442	63445-2442	Conductor Anvil	1 Y
3	63443-0002	63443-0002	Cut-Off Plunger Front	1 Y
4	63443-0012	63443-0012	Plunger Retainer Front	1 Y
Other Components (REF 006750)				
5	11-18-4083	60707-8	Feed Guide	1
6	11-24-1067	4996-4	Cut-Off Plunger Spring	1
7	11-40-4039	8302-5	Plunger Striker	1
8	63443-0009	63443-0009	Front Scrap Chute	1
9	63443-0025	63443-0025	Key	1
10	63443-0090	63443-0090	Wire Stop	1
11	63443-1717	63443-1717	18.70mm Height Spacer	1
12	63443-2202	63443-2202	2.00mm Coarse Spacer	1
13	63443-2216	63443-2216	16.00mm Coarse Spacer	1
14	63443-2315	63443-2315	3.75mm Fine Spacer	1
15	63443-6121	63443-6121	Rear Cover	1
Frame				
16	63800-4901	63800-4901	Top	1
17	63801-3281	63801-3281	Base	1
18	63801-4650	63801-4650	Track	1
Hardware				
19	N/A	N/A	M3 by 6 Long SHCS	2**
20	N/A	N/A	M3 by 6 Long FHCS	1**
21	N/A	N/A	M4 by 6 Long SHCS	2**
22	N/A	N/A	M4 by 12 Long BHCS	2**
23	N/A	N/A	M4 by 50 Long SHCS	2**
24	N/A	N/A	M5 by 12 Lg SHCS	1**
25	N/A	N/A	#10-32 by 3/8" Long Flat Point SSS	1**
26	N/A	N/A	#10-32 Hex Jam Nut	1**
** Available from an industrial supply company such as MSC (1-800-645-7270).				

Assembly Drawing

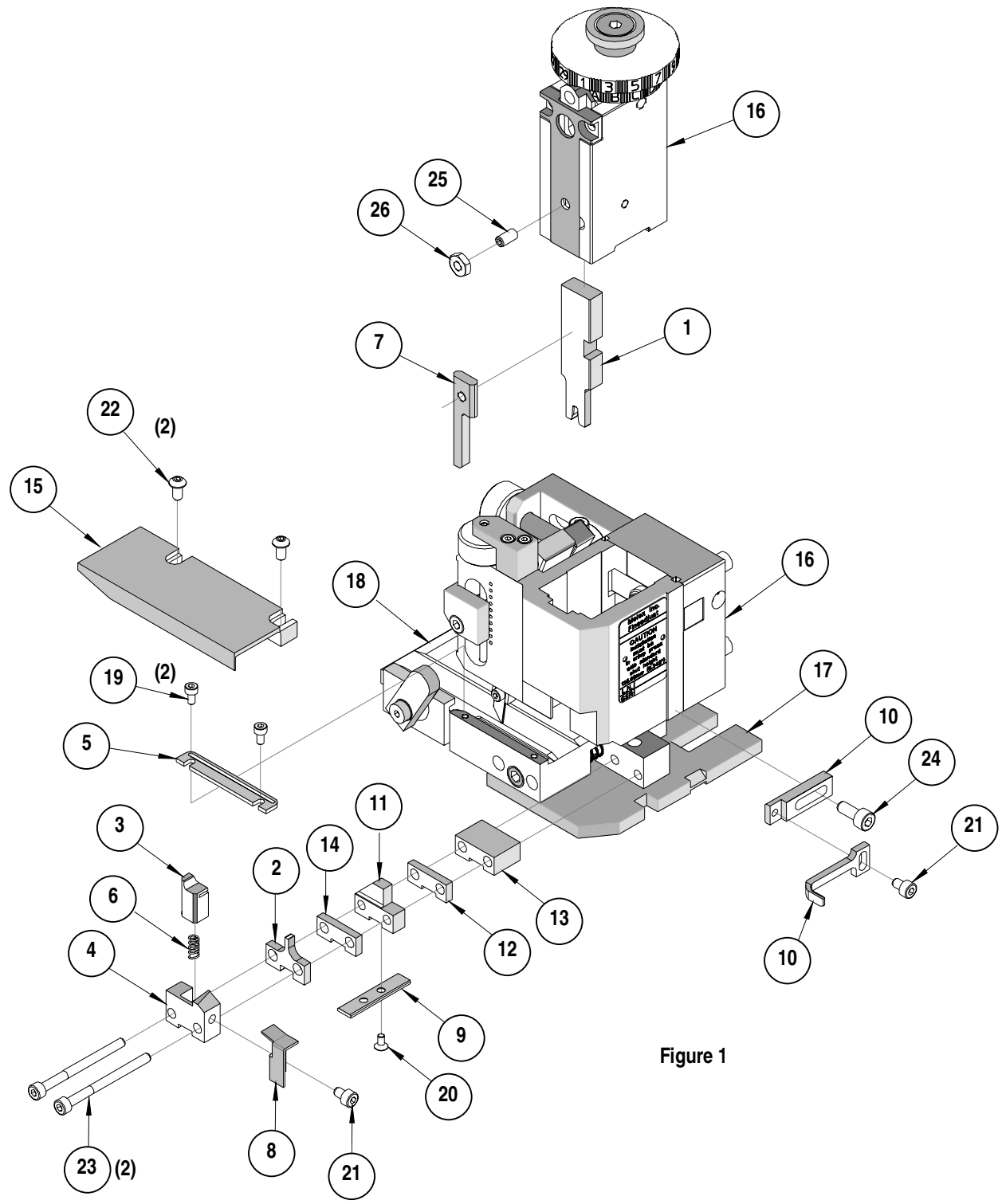

Figure 1

NOTES

1. Molex recommends an extra perishable tooling kit be maintained at your facility.
2. Verify tooling alignment by manually cycling the press and Applicator before crimping under power. Check that all screws are tight.
3. Slugs, Terminals, Dirt and Oil should be kept clear of work area.
4. Wear safety glasses at all times.
5. For recommended maintenance refer to the FineAdjust Manual.

CAUTION: This applicator should only be used in a press with a shut height of 135.80 mm (5.346"). Tooling damage could result at a lower setting.

CAUTION: To prevent injury never operate this Applicator without the guards supplied with the press or wire-processing machine in place. Reference the press or wire processing manufacturer's instruction manual.

CAUTION: Molex crimp specifications are valid only when used with Molex terminals, applicators and tooling.

Americas Headquarters
Lisle, Illinois 60532 U.S.A.
1-800-78MOLEX
amerinfo@molex.com

Far East North Headquarters
Yamato, Kanagawa, Japan
81-462-65-2324
feninfo@molex.com

Far East South Headquarters
Jurong, Singapore
65-6-268-6868
fesinfo@molex.com

European Headquarters
Munich, Germany
49-89-413092-0
eurinfo@molex.com

Corporate Headquarters
2222 Wellington Ct.
Lisle, IL 60532 U.S.A.
630-969-4550
Fax: 630-969-1352

Visit our Web site at <http://www.molex.com>