

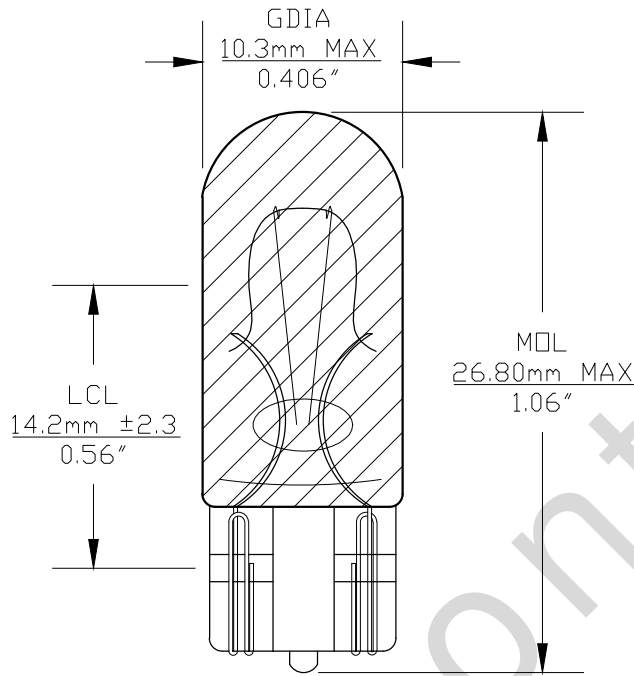

PART NO.	BASE TYPE	DESIGN VOLTS	DESIGN AMPS	MSCD	FILAMENT TYPE	AVERAGE LIFE HOURS	REVISIONS			
							REV #	DESCRIPTION	DATE	APPROVED
168A	Glass Wedge T-3 1/4 (W2.1X9.2d)	14.0V	0.35±10%	2.4 ±30%	C-2F	1500	1	ISSUED	05/23/2014	R.M.

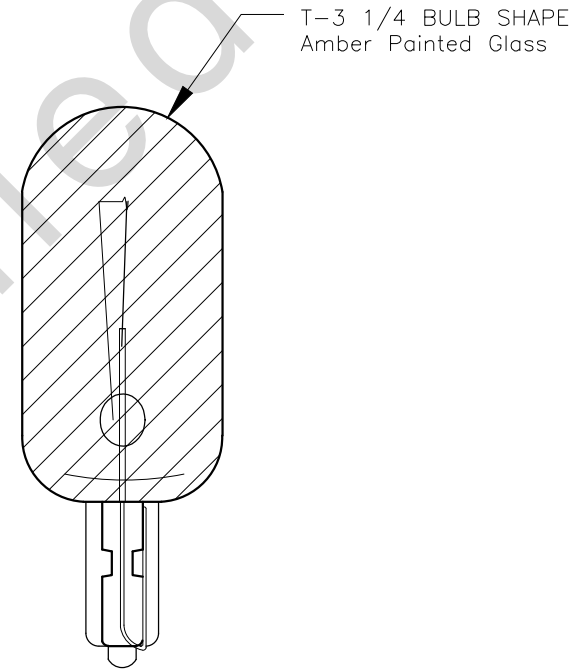

0° VIEW



90° VIEW

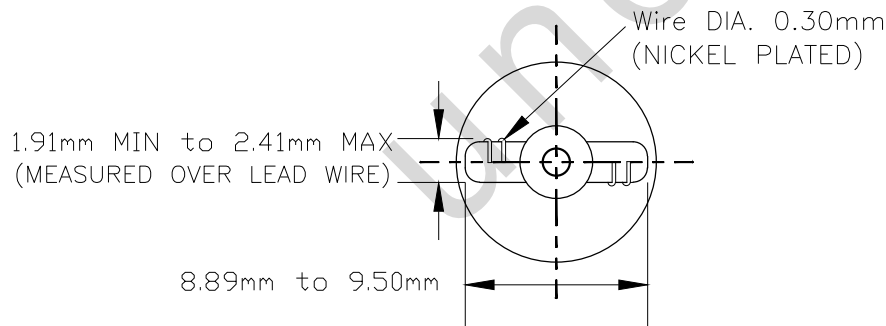

BASE BOTTOM VIEW

Note: Made according to SAE specifications



UNLESS OTHERWISE SPECIFIED: DIMENSIONS ARE IN INCHES TOLERANCES		CEC INDUSTRIES LTD			
DECIMALS	ANGULAR	599 BOND STREET		LINCOLNSHIRE, IL 60069	
.XX ± .05	± 0.5°	TITLE LIGHT BULB NO. 168A			
.XXX ± .010		DATE	05/23/2014	SIZE	A
FRACTIONAL	± 1/64	CHECKED		FSCM NO.	
		DESIGN		DWG NO.	168A
		MATERIAL		SCALE	
				PLOT SCALE	
				SHEET	1 OF 1
				FILE	168A.pdf
				DRAWING NOT TO SCALE	