

THIS DRAWING IS UNPUBLISHED. RELEASED FOR PUBLICATION 20
 © COPYRIGHT 20 BY TYCO ELECTRONICS CORPORATION. ALL INTERNATIONAL RIGHTS RESERVED.

REVISIONS					
P	LTR	DESCRIPTION	DATE	DWN	APVD
A		RELEASED PER ECO-10-008447	21APR2010	DLD	MPT

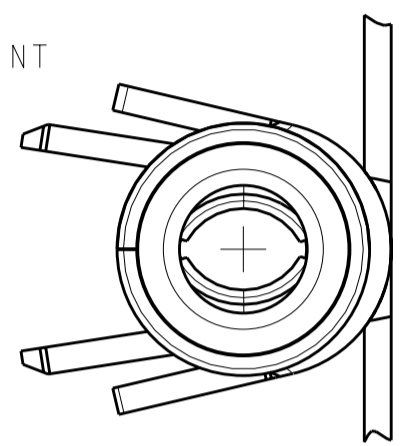
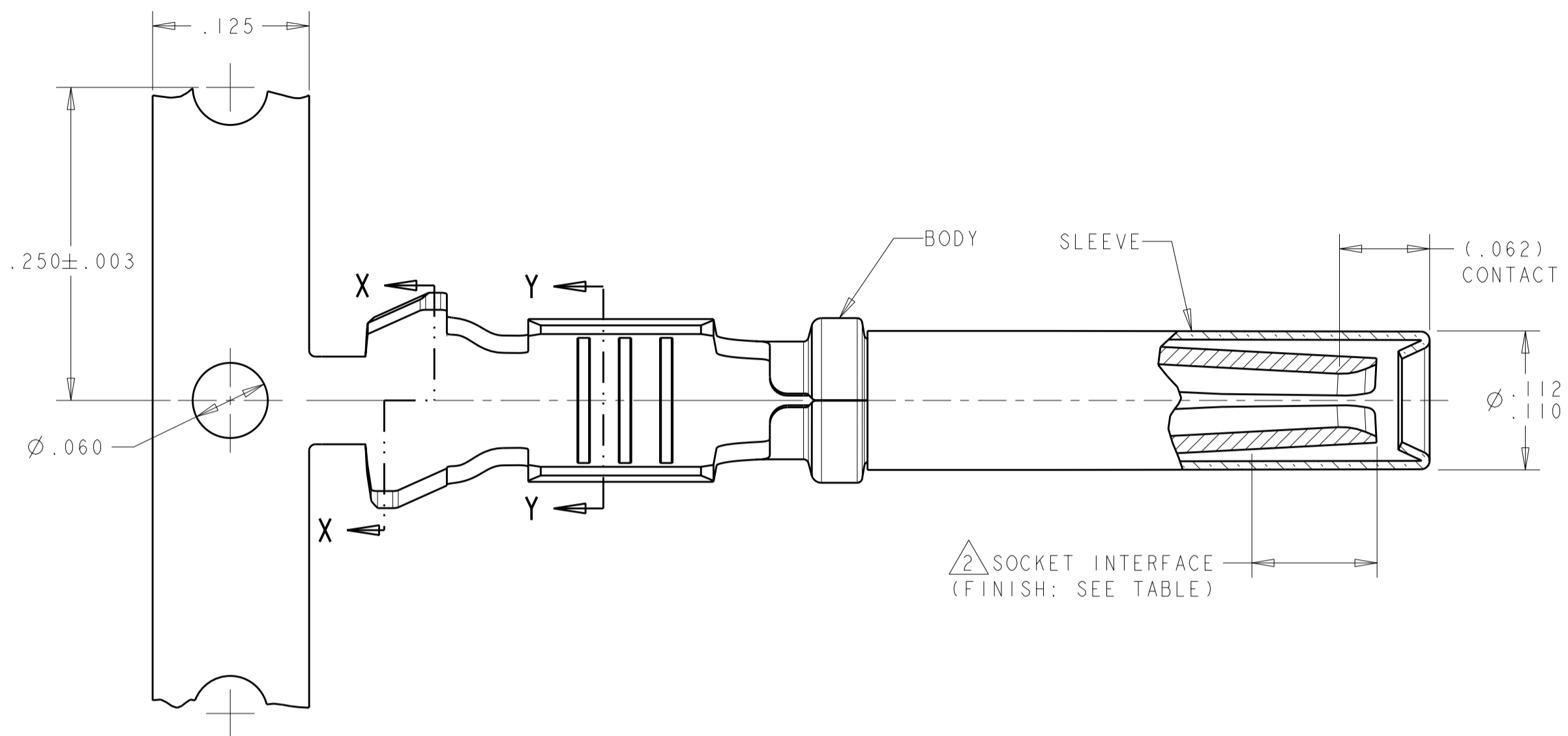

- 1 MATERIAL:
 BODY: .014 THICK COPPER ALLOY
 SLEEVE: .007 THICK STAINLESS STEEL (PASSIVATED)
- 2 FINISH:
 ALL OVER: .000040-.000080 THICK NICKEL
 WIRE BARREL: .000100-.000200 THICK TIN
 SOCKET INTERFACE: (SEE TABLE)
 FOR P/N 2098253-1 ONLY: .000030 MIN THICK GOLD
- 3. WIRE RANGE: 1.5 SQ.MM. TO 2.5 SQ.MM.
 INSULATION DIAMETER RANGE: Ø.083-Ø.128 [Ø2.10-Ø3.25 MM]
 NOTE: THE CONNECTOR THIS TERMINAL IS ASSEMBLED INTO
 MAY LIMIT THE SUITABLE INSULATION DIAMETER RANGE BASED ON
 THE TERMINAL CONFIGURATION.
- 4. CONTACT TO BE LUBED WITH LUBRICANT PER TYCO ELECTRONICS
 P/N 22014-4
- 5. SLEEVE MUST NOT BE PULLED OFF WHEN A 10 LB FORCE IS APPLIED
 IN A DIRECTION PARALLEL TO CENTER OF TERMINAL.

2 SOCKET INTERFACE
 (FINISH: SEE TABLE)

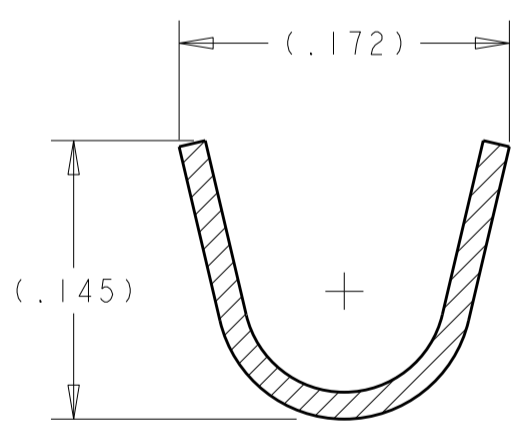
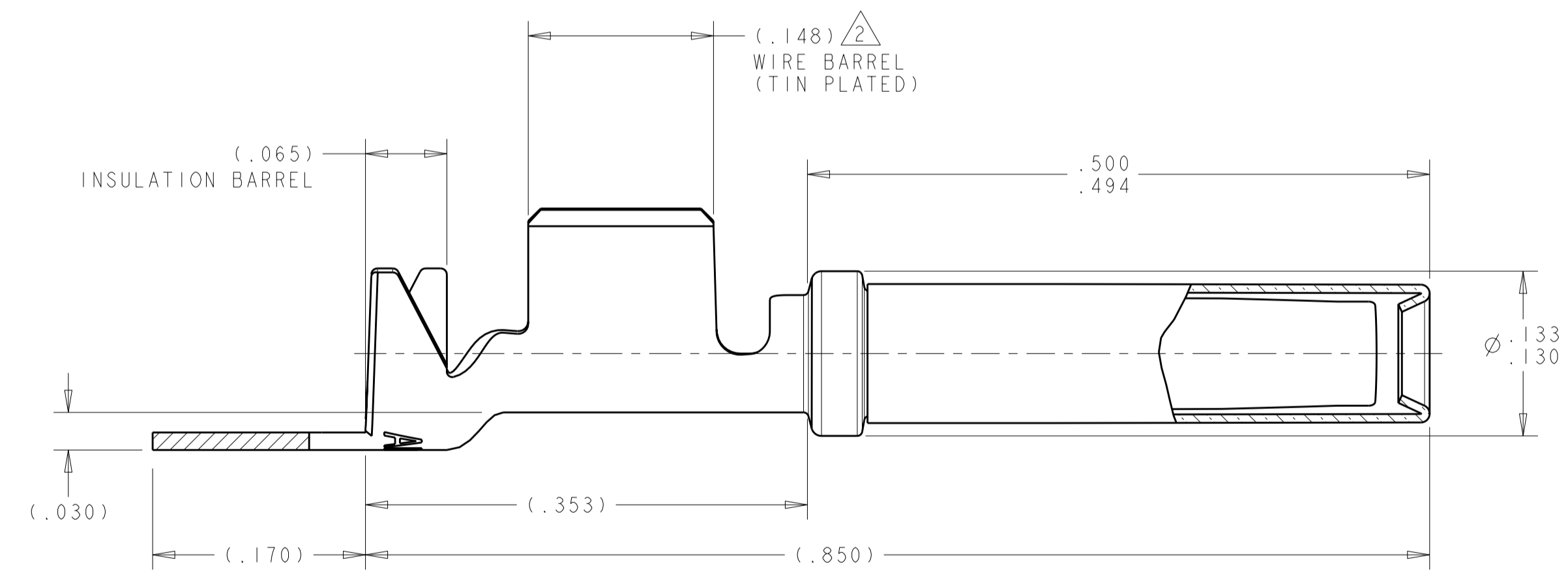

SECTION X-X

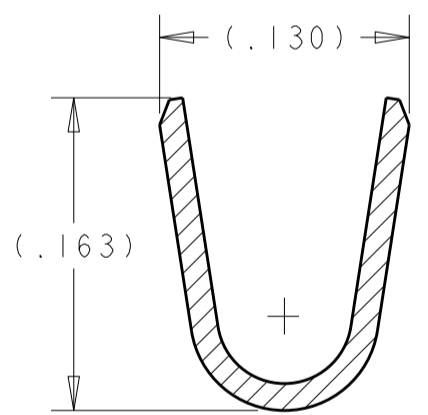

SECTION Y-Y

REELING DIRECTION
 OFF TOP OF REEL

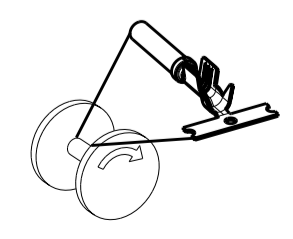

NICKEL	2098253-2
GOLD	2098253-1
FINISH SOCKET INTERFACE (REFERENCE)	PART NUMBER

THIS DRAWING IS A CONTROLLED DOCUMENT FOR TYCO ELECTRONICS CORPORATION IT IS SUBJECT TO CHANGE AND THE CONTROLLING ENGINEERING ORGANIZATION SHOULD BE CONTACTED FOR THE LATEST REVISION.		DWN J. SANDBURG 01 JUL 2009	Tyco Electronics Harrisburg, PA 17105-3608	
DIMENSIONS: INCHES		CHK M. TRULL 06 JUL 2009	NAME SOCKET CONTACT ASSEMBLY SIZE 16 1.5 SQ.MM TO 2.5 SQ.MM. WIRE	
TOLERANCES UNLESS OTHERWISE SPECIFIED:		APVD M. TRULL 14 JUL 2009	PRODUCT SPEC	
0 PLC ± 1 PLC ± 2 PLC ±.02 3 PLC ±.005 4 PLC ± ANGLES ± FINISH		APPLICATION SPEC 114-13045	RESTRICTED TO	
MATERIAL		WEIGHT	SIZE A2	CAGE CODE 00779
1 -		CUSTOMER DRAWING	DRAWING NO C-2098253	REV A
2 -		SCALE 10:1	SHEET 1 OF 1	