

SMT Power Inductors

Toroid - HCCI - 80 Series



- Height:** 12.7mm Max
- Footprint:** 31.0mm x 25.4mm Max
- Current Rating:** up to 38A
- Inductance Range:** 1.1µH to 18.1µH

Electrical Specifications @ 25°C - Operating Temperature -40°C to +130°C⁶

Pulse ^{4,5} Part Number	Inductance @ I _{rated} (µH TYP)	I _{rated} (A)	DCR (mΩ)		Inductance @ 0A _{DC} (µH ±15%)	Reference ET (Volt-µsec)	Flux Density Factor (K1)	Core Loss Factor (K2)	Temp. Rise Factor (K3)	Connection
			TYP	MAX						
P0599NL	1.1	38	1.1	1.3	2.1	4.20	0.62	1.50E-09	33.8	Parallel
P0598NL	1.6	34	1.4	1.6	3.9	4.20	0.48	1.50E-09	33.8	Parallel
P0597NL	2.45	27	2.2	2.5	5.7	6.00	0.39	1.50E-09	33.8	Parallel
P0596NL	3.2	24	3.0	3.5	8.0	4.20	0.33	1.50E-09	33.8	Parallel
P0599NL	4.3	19	4.4	5.1	8.4	8.40	0.31	1.50E-09	33.8	Series
P0595NL	4.52	19	4.2	4.8	10.5	9.00	0.29	1.50E-09	33.8	Parallel
P0598NL	6.4	17	5.6	6.4	15.6	8.40	0.24	1.50E-09	33.8	Series
P0597NL	9.8	13.5	8.8	10.1	22.8	12.00	0.20	1.50E-09	33.8	Series
P0596NL	12.8	12	12.0	13.8	32.0	8.40	0.17	1.50E-09	33.8	Series
P0595NL	18.1	9.5	16.8	19.3	42.0	18.00	0.14	1.50E-09	33.8	Series

Notes:

1. Temperature rise is 55°C in typical buck or boost circuits operating at 300kHz with the rated I_{DC} current and reference ET applied to the inductor.
2. Total loss in the inductor is 1.8W for 55°C temperature rise above ambient.
3. In high volt-time applications, additional heating in the component can occur due to core losses in the inductor which may necessitate derating the current in order to limit the temperature rise of the component. In order to determine the approximate total losses (or temperature rise) for a given application, both copper and core losses should be taken into account.
Estimated Temperature Rise:

$$Trise = K3 * (Coreloss (W) + Copperloss (W))^{0.33} (C)$$

$$CopperLoss = Irms^2 * DCR_Typical (m\Omega) / 1000$$

$$CopperLoss = K2 * (Freq_kHz)^{1.26} * (\Delta B)^{2.11}$$

$$\Delta B = K1 * Volt-\mu sec * 100$$
4. Optional Tape & Reel packaging can be ordered by adding a "T" suffix to the part number (i.e. P0595NL becomes P0595NLT). Pulse complies to industry standard tape and reel specification EIA481.
5. The "NL" suffix indicates an RoHS-compliant part number. Non-NL suffixed parts are not necessarily RoHS compliant, but are electrically and mechanically equivalent to NL versions. If a part number does not have the "NL" suffix, but an RoHS compliant version is required, please contact Pulse for availability.
6. The temperature of the component (ambient plus temperature rise) must be within the stated operating temperature range.

SMT Power Inductors

Toroid - HCCI - 80 Series



Mechanical

Schematic

P059X

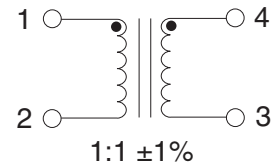
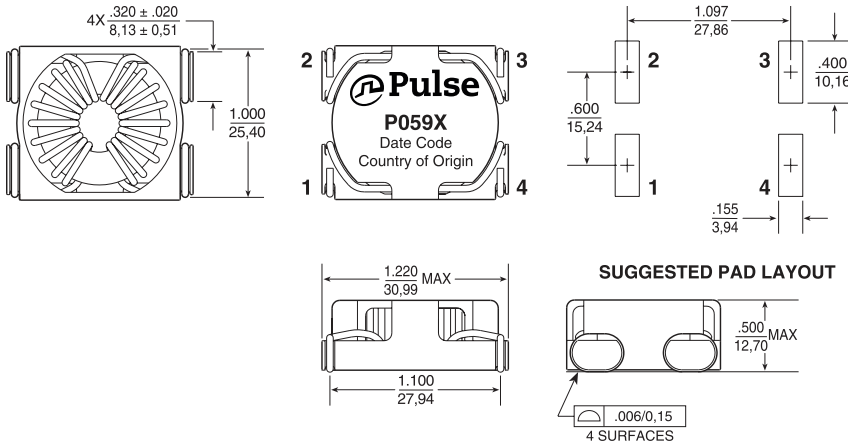

Weight18.7grams
Tape & Reel75/reel
Tube20/tube
Dimensions: ^{Inches}_{mm}
 Unless otherwise specified,
 all tolerances are: $\pm \begin{matrix} .010 \\ 0.25 \end{matrix}$

For More Information

Pulse Worldwide Headquarters

15255 Innovation Drive Ste 100
 San Diego, CA 92128
 U.S.A.

Pulse Europe

Pulse Electronics GmbH
 Am Rottland 12
 58540 Meinerzhagen
 Germany

Pulse China Headquarters

Pulse Electronics (ShenZhen) CO., LTD
 D708, Shenzhen Academy of
 Aerospace Technology,
 The 10th Keji South Road,
 Nanshan District, Shenzhen,
 P.R. China 518057

Pulse North China

Room 2704/2705
 Super Ocean Finance Ctr.
 2067 Yan An Road West
 Shanghai 200336
 China

Pulse South Asia

3 Fraser Street 0428
 DUO Tower
 Singapore 189352

Pulse North Asia

1F., No.111 Xiyuan Road
 Zhongli District
 Taoyuan City 32057
 Taiwan (R.O.C)

Tel: 858 674 8100
 Fax: 858 674 8262

Tel: 49 2354 777 100
 Fax: 49 2354 777 168

Tel: 86 755 33966678
 Fax: 86 755 33966700

Tel: 86 21 62787060
 Fax: 86 2162786973

Tel: 65 6287 8998
 Fax: 65 6280 0080

Tel: 886 3 4356768
 Fax: 886 3 4356820

Performance warranty of products offered on this data sheet is limited to the parameters specified. Data is subject to change without notice. Other brand and product names mentioned herein may be trademarks or registered trademarks of their respective owners. © Copyright, 2019. Pulse Electronics, Inc. All rights reserved.