

REVISIONS

P	LTR	DESCRIPTION	DATE	DWN	APVD
	A	RELEASE	06SEP2016	X.Z	S.Z
	B	ECO-18-016894 combine QR code to label	25OCT2018	T.Z	XN.Z
	B1	Add 3C LOGO ECO-20-016235	25NOV2020	T.Z	XN.Z

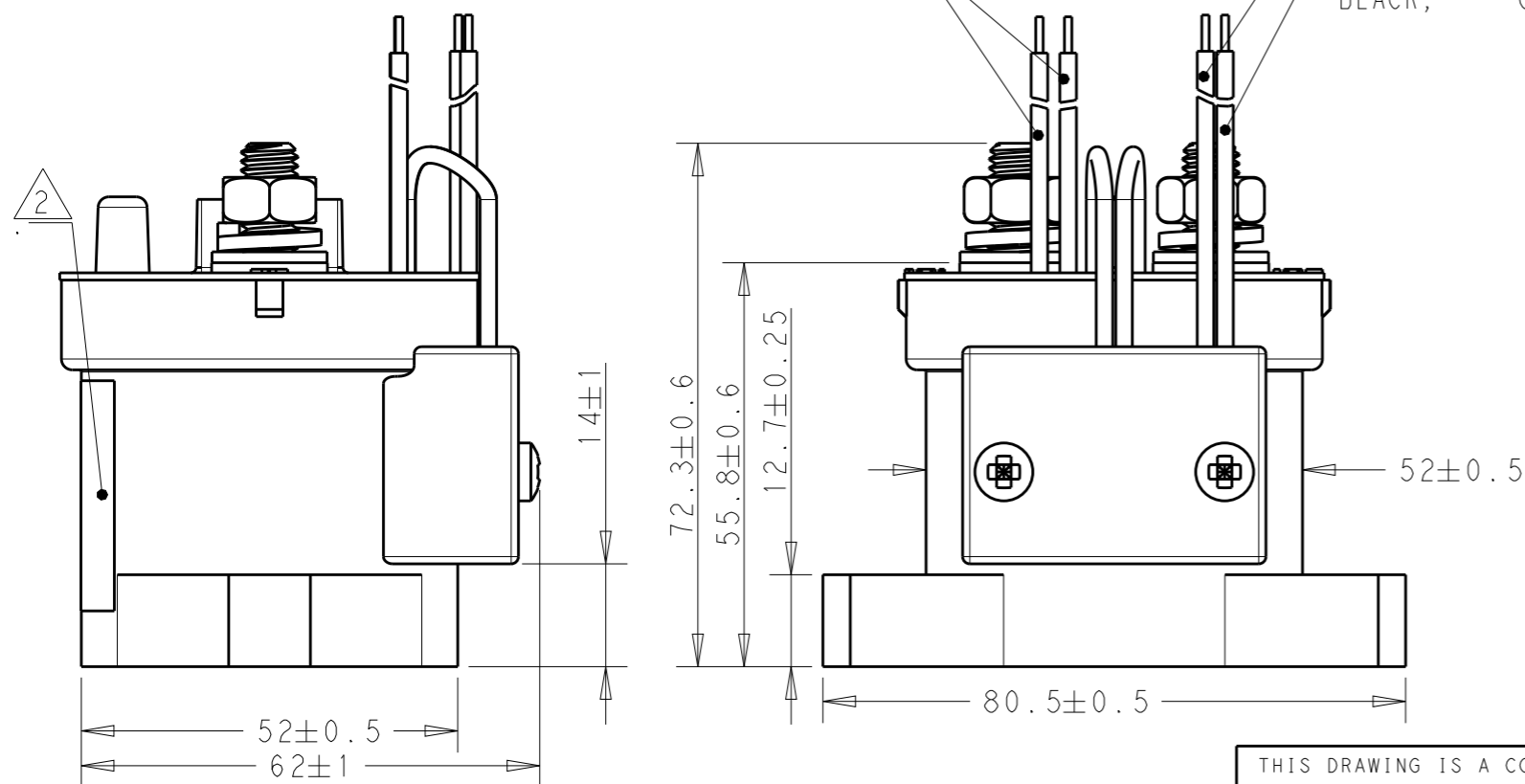
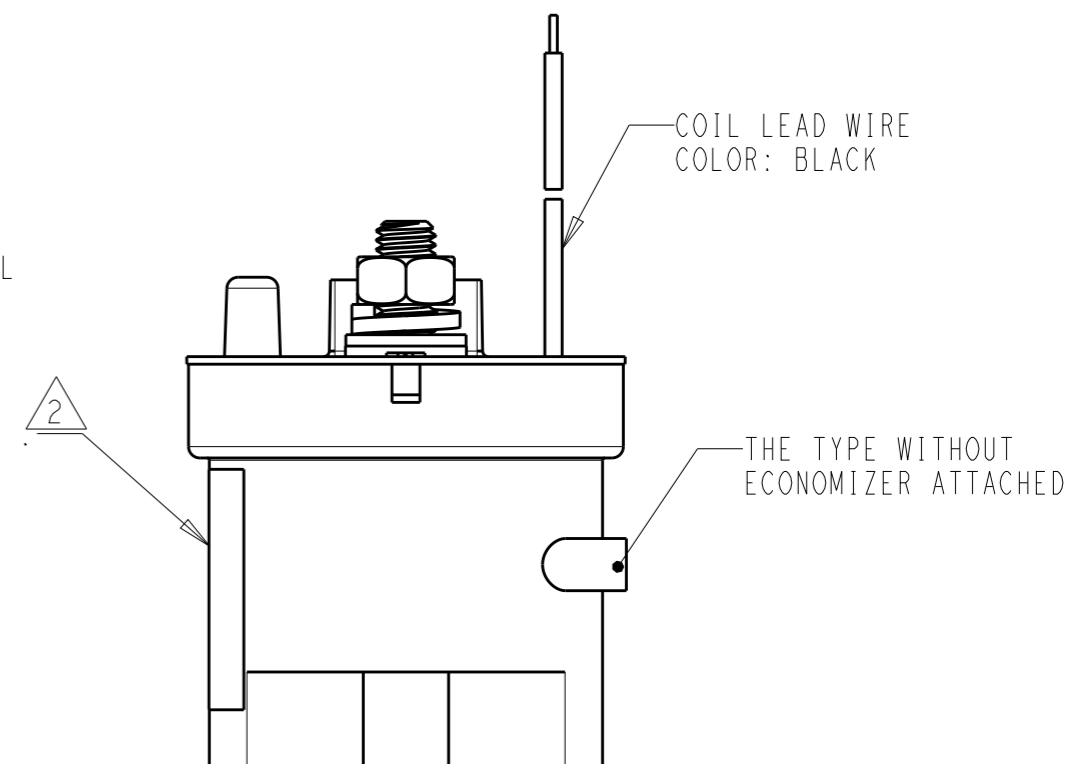
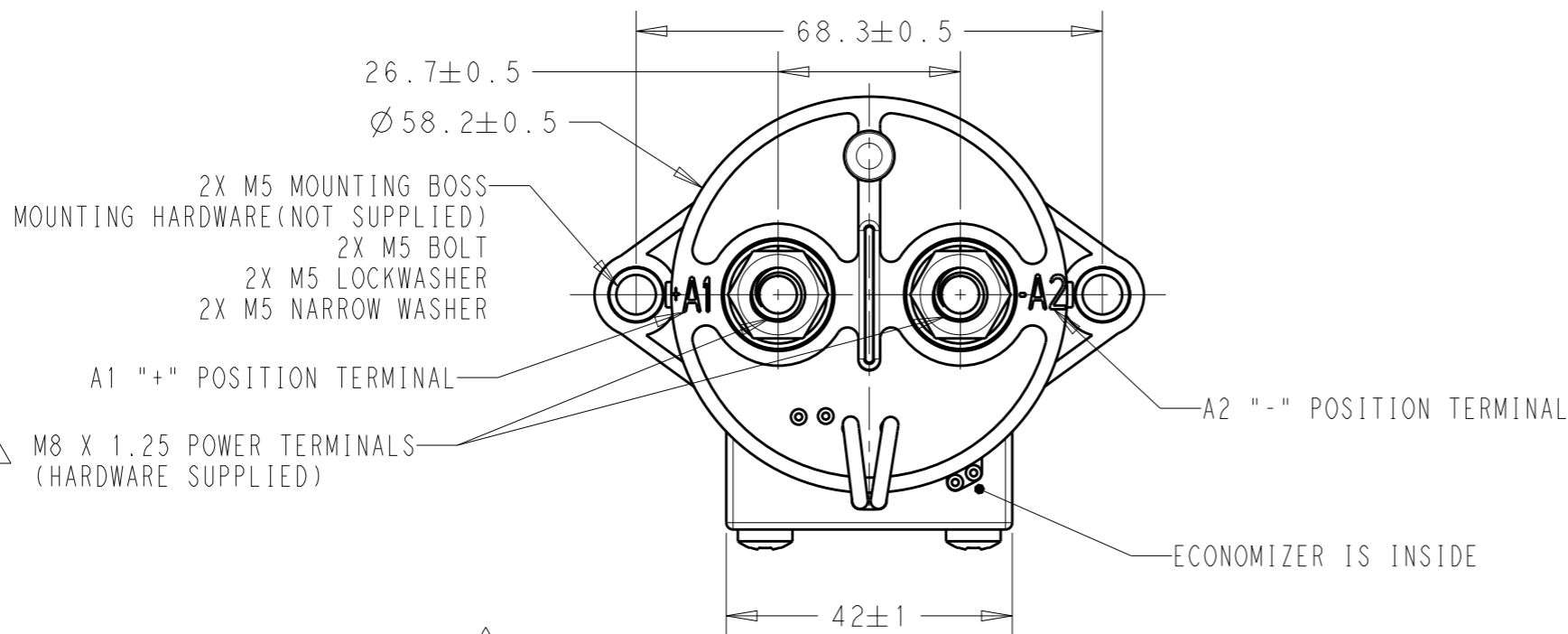

NOTES:

- 1. HARDWARE IS SUPPLIED IN KIT
 2X M8 WASHER, STAINLESS
 2X M8 LOCKWASHER-SPOT RING, STAINLESS
 2X M8X1.25 NUT, STAINLESS
- 2. LABEL, QR CODE PRINTED CONTENT.
 MMY-001, PPPPPP, 0001

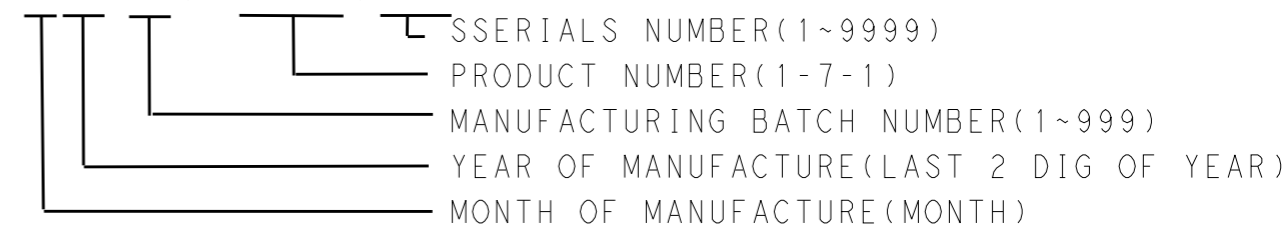

- 3. LEAD WIRES:
 UL3321, 22AWG
 LENGTH = 380MM ± 20MM

THIS DRAWING IS A CONTROLLED DOCUMENT.		DWN XN.ZHANG	06SEP2016	TE Connectivity	
DIMENSIONS: mm		CHK -	-		
TOLERANCES UNLESS OTHERWISE SPECIFIED:		APVD SUNNY_ZHANG	06SEP2016	NAME IHV200 SERIES PRODUCT	
0 PLC ±- 1 PLC ±0.1 2 PLC ±0.01 3 PLC ±0.001 4 PLC ±0.0001 ANGLES ±-		PRODUCT SPEC -		APPLICATION SPEC -	
MATERIAL -		FINISH -		SIZE A3	CAGE CODE -
		WEIGHT -		DRAWING NO C-2071410	RESTRICTED TO -
CUSTOMER DRAWING				SCALE 1:1	SHEET 1 OF 2
				REV B1	

REVISIONS

P	LTR	DESCRIPTION	DATE	DWN	APVD
		SEE SHEET 1			

LABEL PRINT CONTENT

SCALE 4:1

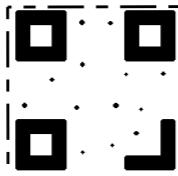

QR CODE

(B)

CHINA

RELAY IHV200AAANA

PRODUCT NAME

P/N 2071410-1

PART NUMBER



GB/T 14048.5

(B1)

Coil: 12-24VDC

COIL VOLTAGE RANGE

ECONOMIZER ATTACHED

ECONOMIZER STATE

1630

STV29

PRODUCTION DATE "YYWW"

MANUFACTURING FACILITY CODE

UNATTACHED	NORMALLY OPEN	72 VDC	IHV200H3ANA	3-2071410-3
UNATTACHED	NORMALLY OPEN	48 - 72 VDC	IHV200H2ANA	3-2071410-2
UNATTACHED	NORMALLY OPEN	12 - 24 VDC	IHV200H1ANA	3-2071410-1
ATTACHED	NORMALLY OPEN	72 VDC	IHV200HJANA	2-2071410-3
ATTACHED	NORMALLY OPEN	48 - 72 VDC	IHV200HDANA	2-2071410-2
ATTACHED	NORMALLY OPEN	12 - 24 VDC	IHV200HAANA	2-2071410-1
UNATTACHED	NONE	72 VDC	IHV200A3ANA	1-2071410-3
UNATTACHED	NONE	48 - 72 VDC	IHV200A2ANA	1-2071410-2
UNATTACHED	NONE	12 - 24 VDC	IHV200A1ANA	1-2071410-1
ATTACHED	NONE	72 VDC	IHV200AJANA	2071410-3
ATTACHED	NONE	48 - 72 VDC	IHV200ADANA	2071410-2
ATTACHED	NONE	12 - 24 VDC	IHV200AAANA	2071410-1
ECO. STATE	AUX. CONTACT	COIL VOLTAGE	PRODUCT NAME	PART NUMBER

THIS DRAWING IS A CONTROLLED DOCUMENT.		DWN	-		
		CHK	-		
		APVD	-		
		PRODUCT SPEC	-		
DIMENSIONS: mm		TOLERANCES UNLESS OTHERWISE SPECIFIED:		NAME	
		0 PLC ±-		-	
		1 PLC ±0.1		-	
		2 PLC ±0.01		-	
		3 PLC ±0.001		-	
		4 PLC ±0.0001		-	
MATERIAL		FINISH		SIZE	
-		-		A3	
				CAGE CODE	
				-	
				DRAWING NO	
				C-2071410	
				RESTRICTED TO	
				-	
				SCALE	
				4:1	
				SHEET	
				2 OF 2	
				REV	
				B1	
				CUSTOMER DRAWING	