

RPC-N 50 Ω  
RPC-N 75 Ω

Gauge Jack

**05W00K-000**

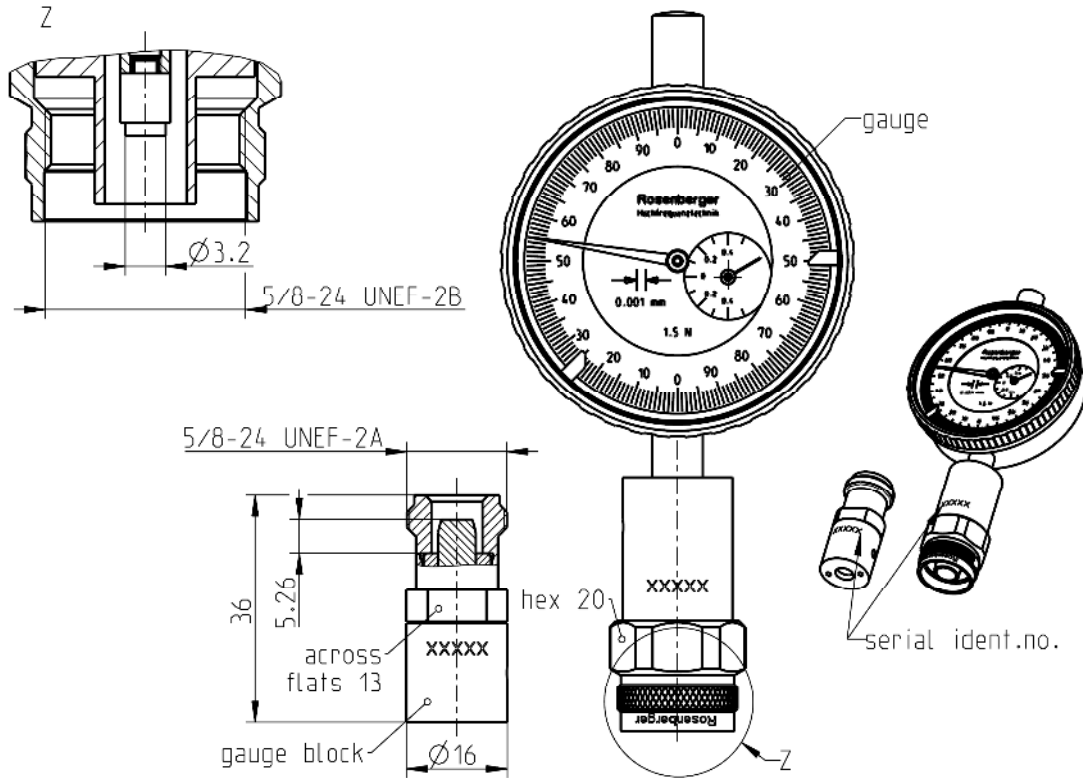

All dimensions are in mm; tolerances according to ISO 2768 m-H

**Documents**

Application note

AN001 "Calibration Services"

**Material and plating**

**Connector parts**

Center and outer contact  
Coupling nut  
Gauge block body

**Material**

Stainless steel  
Stainless steel  
Stainless steel

**Plating**

N/A  
Passivated  
N/A

**Mechanical data**

Gauge block nominal gauge	5.26 mm
Gauge range	5.26 mm ± 0.5 mm
Scale gradation	1 µm
Limit of measurement error <sup>1,2</sup>	≤ 10 µm
Typical measurement error <sup>1,2</sup>	≤ 6 µm
Measuring force	1.5 N

<sup>1</sup> When zeroed with gauge block  
<sup>2</sup> 5.14 mm to 5.30 mm

RPC-N 50 Ω  
RPC-N 75 Ω

Gauge Jack

**05W00K-000**

**Declaration of calibration options**

**Factory Calibration**

Standard delivery for this gauge includes a Factory Calibration. The Calibration Certificate issued reports individual mechanical calibration results, traceable to national / international standards.

**Accredited Calibration**

Not available.

*For further, more detailed information see application note AN001 on the Rosenberger homepage.*

**Calibration interval**

Recommendation 12 months

**Packing**

Standard 1 pce in box  
Weight 249 g/pce

While the information has been carefully compiled to the best of our knowledge, nothing is intended as representation or warranty on our part and no statement herein shall be construed as recommendation to infringe existing patents. In the effort to improve our products, we reserve the right to make changes judged to be necessary.

Draft	Date	Approved	Date	Rev.	Engineering change number	Name	Date
Herbert Babinger	09.03.05	Martin Moder	29.01.15	g00	14-1492	Herbert Babinger	29.01.15

Rosenberger Hochfrequenztechnik GmbH & Co. KG  
P.O.Box 1260 D-84526 Tittmoning Germany  
www.rosenberger.de

Tel. : +49 8684 18-0  
Email : info@rosenberger.de

Page  
2 / 2