

(b) STRIPPING DIMENSIONS

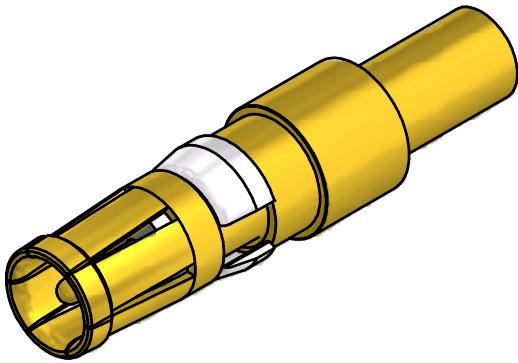
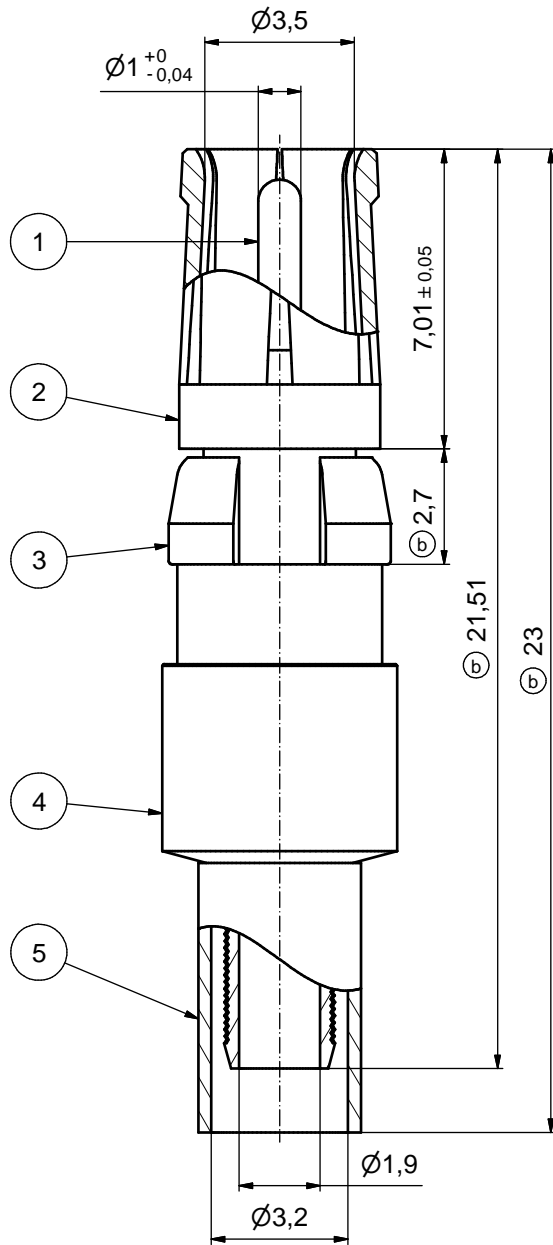
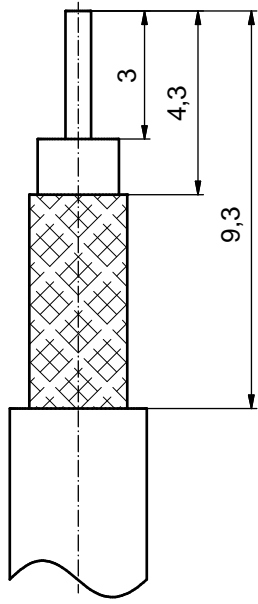

(b) ASSEMBLY TOOLING:

1. CENTER CONTACT:
USE CRIMP TOOL: 360X10329X
WITH TOOL INSERT: 360X11049X
SELECTOR SETTING: 5 (FOR AWG26 CENTER CONDUCTOR OF CABLE)
2. CRIMP FERRULE:
USE CRIMP TOOL: 360X10519X
WITH TOOL INSERT: 360X11019X
INSERT CAVITY B: HEX 3.25/.128

(b)

Part no.	Finish Pos.1	Finish Pos.2	Finish Pos.3	Finish Pos. 4/5
132J21019X	min. 50µin HARD GOLD over min. 50µin NICKEL	min. 30µin HARD GOLD over min. 50µin NICKEL	NICKEL PLATED	GOLD FLASH over NICKEL
132A21019X	GOLD FLASH over NICKEL	GOLD FLASH over NICKEL	NICKEL PLATED	GOLD FLASH over NICKEL

Directive 2002/95/EC RoHS compliant

THIS DRAWING MAY NOT BE COPIED OR REPRODUCED IN ANY WAY, AND MAY NOT BE PASSED ON TO A THIRD PARTY WITHOUT WRITTEN PERMISSION. OWNERSHIP AND COPYRIGHT OF CONEC GmbH DO NOT ALTER CAD DRAWING BY HAND	tolerance		dim. in mm		scale: 8:1
	date		name		material: COPPER ALLOY (Pos.1 - 5) (b)
	drawn	16.04.09	Sonnenberg		title: COAXIAL CONTACT SOCKET 50 OHM inner + outer conductor for crimp termination for cable 174U,188AU, 316U
	appd.	16.04.09	Koch		
	norm				
d-old				dwg no: Inventor 10	DIN-A3
7 x b	Ä 3774	12.10.10	HS		
a	Origin				
rev.	description	date	name	part no: see table	