

CPG005_DRV88xx Evaluation Modules

This document is provided as a supplement to the DRV8840 and DRV8842 datasheets. It details the hardware implementation of the CPG005_DRV88xxEVM Customer Evaluation Module (EVM). On this document, DRV88xx will be used interchangeably to refer to any of the aforementioned devices.

Contents

1	Block Diagram	2
1.1	Power Connectors	2
1.2	Test Stakes	2
1.3	Jumpers	2
1.4	Motor Outputs	3
2	Installing Drivers And Software	4
2.1	Installing the FTDI USB Driver	4
2.2	Installing the CPG004_DRV88xx Evaluation Board Windows Application Software	4
2.3	Running the Windows Application Software	4
3	The Windows Application	4
3.1	The Menu	7
3.2	DRV88xx GPIO Control Signals	7
3.3	Updating DAC Output for Current Control (VREFA and VREFB)	8
3.4	DC Motor Speed Control (PWM)	8
4	Schematic	9

List of Figures

1	AVREF Select Jumper Configuration	3
2	DECAY Select Jumper Configuration	3
3	DRV8840 Tab	5
4	DRV8842 Tab	6
5	GPIO Control Signals.....	7
6	Current Control	8
7	PWM Control	9

1 Block Diagram

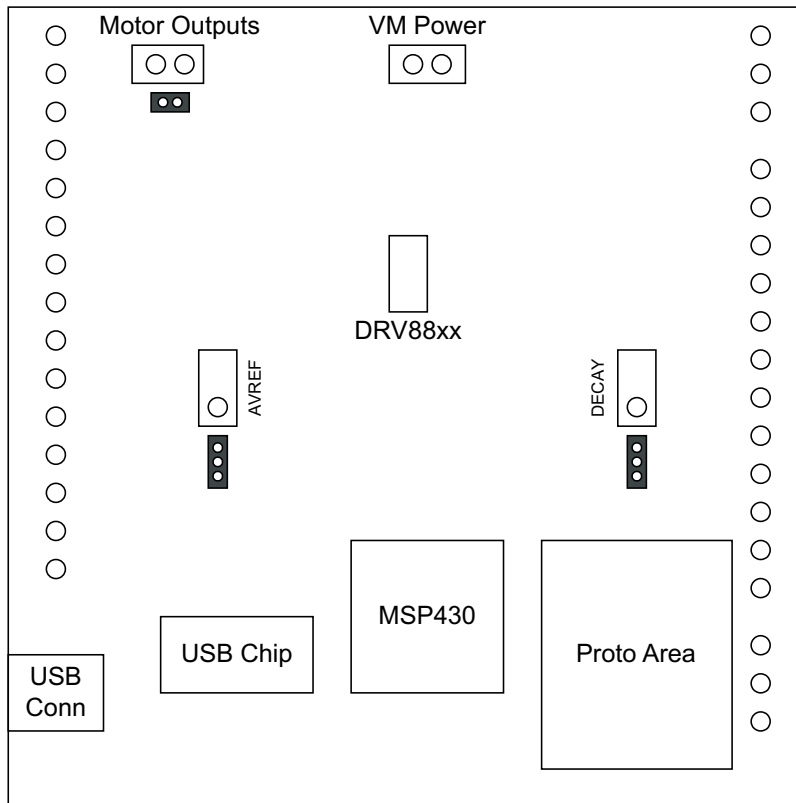

Where DRV88xx stands for one of DRV8840 or DRV8842

1.1 Power Connectors

The CPG005_DRV88xx Customer EVM offers access to VM (Motor Voltage) power rail via a terminal block (J1). A set of test clips in parallel with the terminal block allows for the monitoring of the input power rail.

User must apply VM according to datasheet recommended parameters.

NOTE: VDD for logic and microcontroller is derived from USB interface.

1.2 Test Stakes

Every pin on the DRV88xx device has been brought out to a test stake. A label on the silkscreen identifies each signal.

For those pins that change functionality depending on device flavor, a table is provided with corresponding function name on its particular column.

1.3 Jumpers

There are only three jumpers the user must configure as detailed below. Default configuration assumes microcontroller resources are being utilized. As an alternative, a variable resistance is provided on the opposing jumper configuration.

1.3.1 AVREF Select Jumper (JP2)

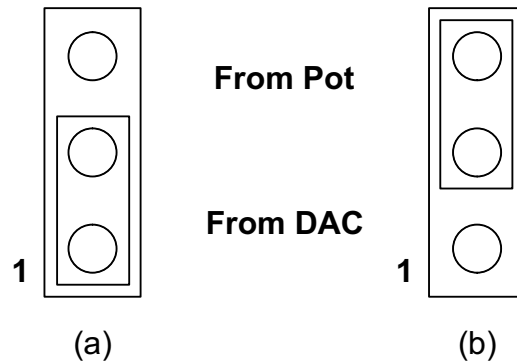

To configure the AVREF select jumper:
 (a) Use position JP2-1:2 to select the MSP430 DAC output (default).
 (b) Use position JP2-2:3 to select the respective variable resistance potentiometer. This jumper should not be left open as lack of reference voltage on the device will minimize current sourcing into the respective H Bridge, resulting in very poor motion or no motion at all.

Figure 1. AVREF Select Jumper Configuration

1.3.2 DECAY Select Jumper (JP3)

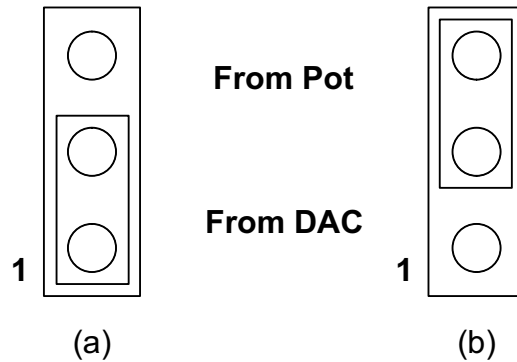

To configure the DECAY select jumper:
 (a) Use position JP3-1:2 to select the MSP430 GPIO functionality (default).
 (b) Use position JP3-2:3 to select the respective variable resistance potentiometer. Allowing the jumper to not be placed, will result in the device operating under mixed decay mode.

Figure 2. DECAY Select Jumper Configuration

1.4 Motor Outputs

There are two ways of connecting the DC motor into the CPG005_DRV88xx Evaluation Module: two pin header (J4) or two position terminal block (J3). Although feasible, we do not recommend the connection of any motor into the test clips as these are Kelvin connections and not rated for high current output.

2 Installing Drivers And Software

2.1 Installing the FTDI USB Driver

Instructions on how to install the FTDI USB driver on a Windows based computer are detailed in the "USB_Drivers_Install_Readme.pdf" file supplied with the CD inside the USB_Driver folder.

2.2 Installing the CPG004_DRV88xx Evaluation Board Windows Application Software

The Windows application for the CPG005 based EVM's is the same Windows Application as for the CPG004 based EVM's.

Copy the contents of the "WindowsApplication" folder provided within the CD, into your hard disk.

2.3 Running the Windows Application Software

To run the application, double click the CPG004_DRV88xxEVM.exe application icon found on the same folder the application was extracted into.

3 The Windows Application

The CPG004_DRV88xxEVM Windows application is the software counterpart for the CPG004_DRV88xx EVM. It allows the PC computer to connect to the MSP430F1612 microcontroller though an USB interface chip. Once connection is established and commands are sent, microcontroller takes care of configuring control signals and administering certain levels of automation, such as PWM output.

The graphical user interface (GUI) has been designed to allow for all of the DRV88xx device's functionality to be tested without having to intervene with the hardware, except for the proper configuration of jumpers, when needed.

[Figure 3](#) shows the CPG004_DRV88xxEVM.exe main screen. The application is divided into several tabs: One for each one of the available devices. The menu contains items to configure and enable/disable the serial port.

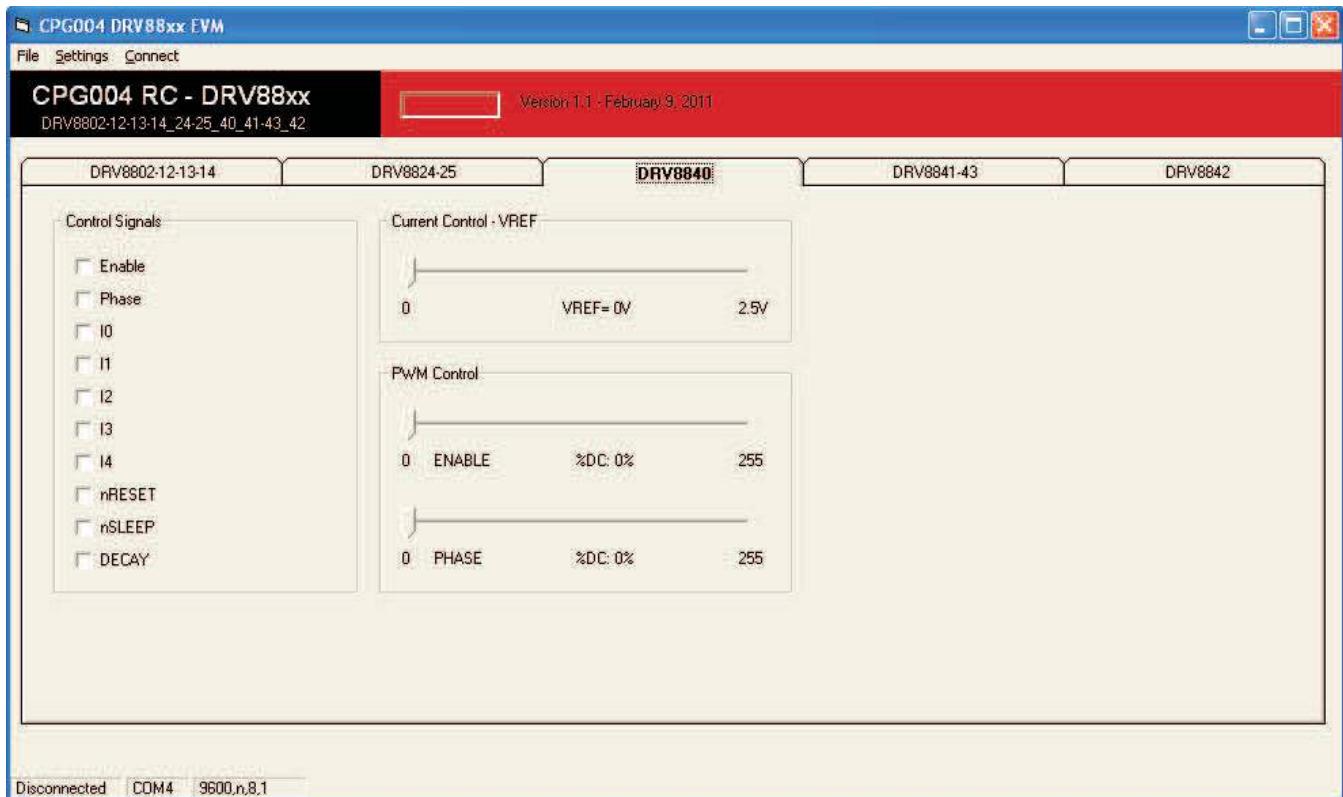

Figure 3. DRV8840 Tab

On the CPG004 DRV88xx EVM Windows Application there are two tabs usable with the CPG005 based EVMs. They are very similar and refer to the differences in the two devices, namely the ENABLE/PHASE interface and the IN1/IN2 interface. Everything else will operate in the same fashion.

All the control signals needed to control motor enablement (ENABLE or INx), direction of rotation (PHASE or the respective combination of the INx pins), current control (through VREF) and PWM control for both enablement and direction control signals are made available.

Access to the DAC responsible of generating the VREF analog voltage is achieved by moving a simple slider. A label offers information on what this reference voltage should be on a scale ranging from 0 V to 2.5 V.

Similar sliders allow the control of PWM Duty Cycle on the ENABLE and PHASE pins (IN1 and IN2 on the DRV8842). This will allow for the control of both DC motor speed and direction.

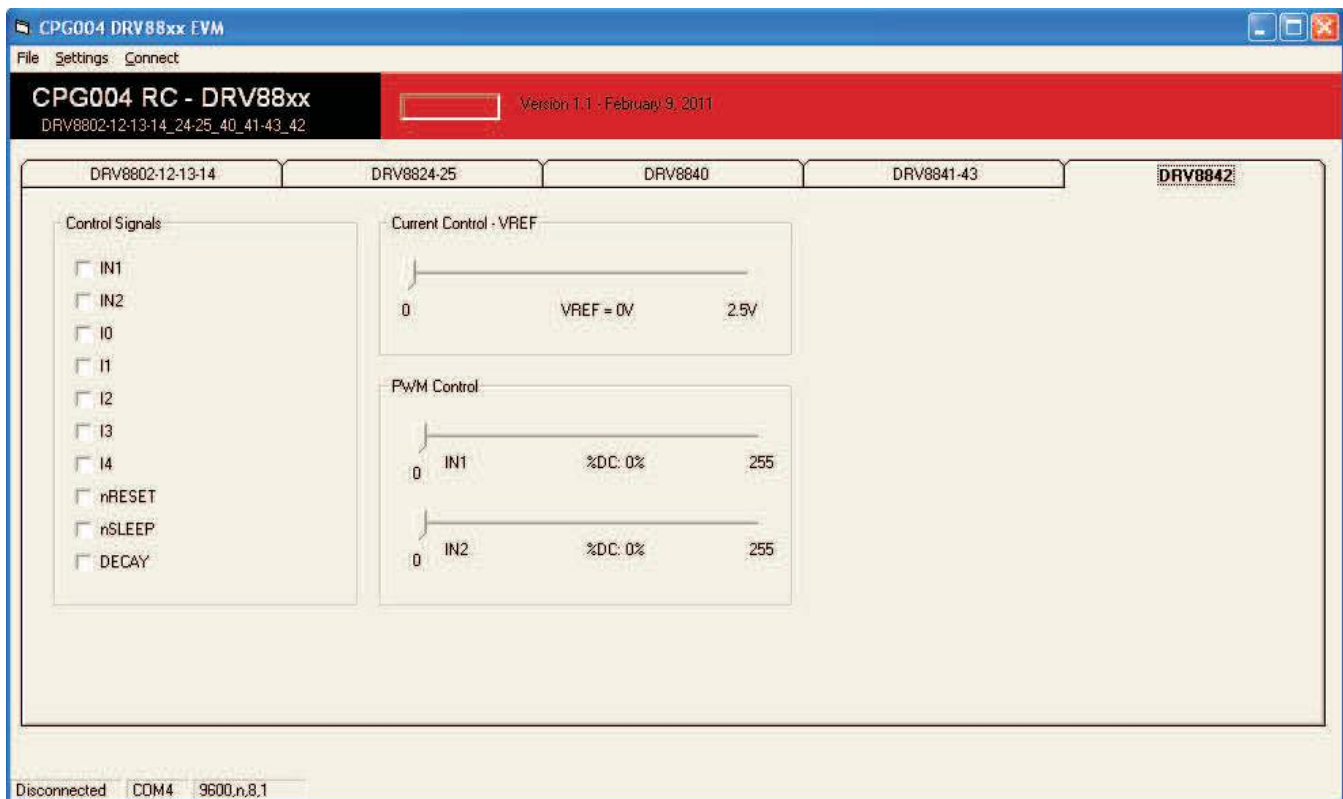

Figure 4. DRV8842 Tab

A look at the DRV8842 tab on the CPG004 DRV88xx EVM Windows Application.

This tab is virtually identical to the DRV8840 tab. Only labels of respective signals differ:

- ENABLE becomes IN1
- PHASE becomes IN2

3.1 The Menu

The menu at the top of the application offers a series of quick options for how the COM port is to behave.

File: Exit – Terminates the application

Settings: Port – Selects from COM1 to COM4. Default is COM4.

The serial port's actual port number defaults to what we have specified on the "USB_Drivers_Install_Readme.pdf". However, any port between COM 1 and COM 4 are equally usable.

Connect: Opens the serial port. When this menu item is pressed, its caption changes to "Disconnect".

Disconnect: Closes the serial port. When this menu item is pressed, its caption changes to "Connect".

After opening the application, the order of events should be:

1. Go to Settings → Port and choose the COM Port where the FTDI device has been configured to work. If the COM port is 4, then this step can be skipped, as application defaults to COM4.
2. Press Connect. If the port is available, the menu changes the "Connect" caption to "Disconnect". Press Disconnect to disable the serial communications.
3. After pressing any command button, <1><0><0> should return on the text box as an acknowledge. The text box also changes from red to green.
4. The application is ready for use.

3.2 DRV88xx GPIO Control Signals

Once the application is communicating with the interface board, the control signals can be actuated by checking or un-checking check boxes on the Control Signals frame.

Functionality of control signals is identical across the platform. A checked checkbox translates to a HI level on the respective control signal. Unchecked checkboxes translate to a LO level on the respective control signals.

Both tabs (DRV8840 and DRV8842) will have a very similar set of control signals. Changes to reflect correct signal naming have been incorporated.

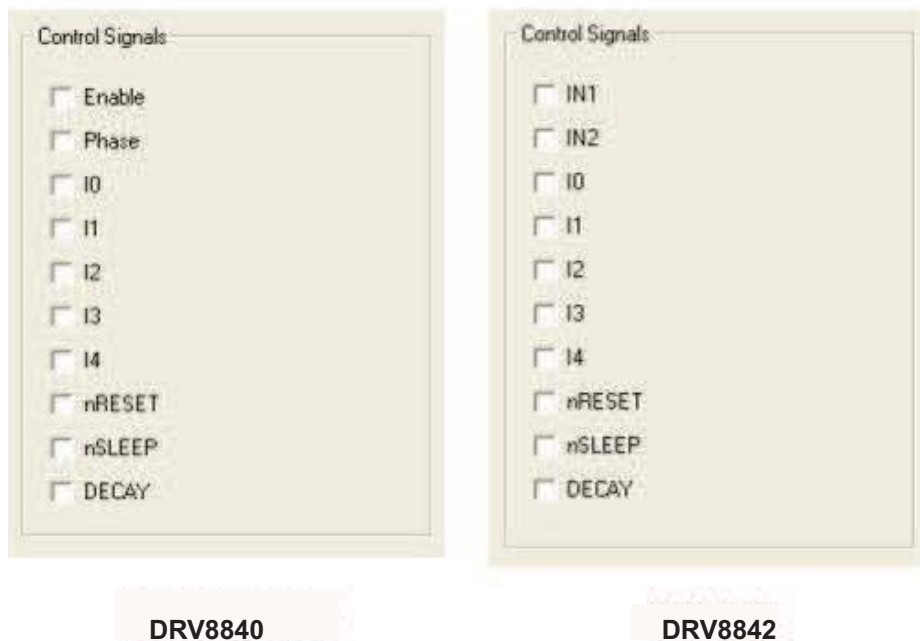

Figure 5. GPIO Control Signals

3.2.1 About DECAY

The DECAY pin is in reality a triple state input. The GPIO operates as HI and LO according to the checkbox. To have the DECAY pin floating, engaging mixed decay mode, simply remove the decay jumper JP3.

3.3 Updating DAC Output for Current Control (VREFA and VREFB)

If the DRV88xx has been configured to accept VREF analog voltages through the microcontroller DAC outputs (refer to Jumpers section), then the slider bar on the Current Control frame can be used to set the VREF voltage. The label below the slider bar will inform the user what this analog voltage should be set to, if proper communications have been established with the EVM module.

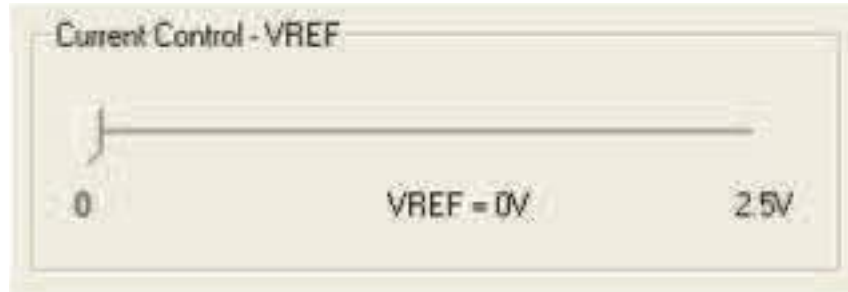

Figure 6. Current Control

The 12-bit DAC channels 0/1 are connected to the DRV88xx VREF analog inputs VREF. Changing the DAC digital value from 0 to 4095, changes the analog voltage at the respective VREF pin from 0 V to 2.5 V respectively, following the equation:

$$VREF = DAC_VALUE \cdot \frac{2.5\text{ V}}{4095} \quad (1)$$

Where:

VREF is the output voltage.

DAC_VALUE is a number from 0 to 4095.

3.4 DC Motor Speed Control (PWM)

For the purpose to control DC motor speed and direction, sliders have been provided which apply a PWM to the ENABLE and PHASE lines (IN1 and IN2 on the DRV8842 variant). Each PWM slider consists of an 8-bit number so positions from 0 to 255 are obtained. A label below the slider bar informs the user what the obtained duty cycle should be, if proper communications have been established with the EVM module.

The MSP430 microcontroller directly transforms this 8-bit number into the respective duty cycle. PWM frequency is around 31.25 kHz.



Figure 7. PWM Control

4 Schematic

A schematic is available in the form of a PDF file (“CPG005_Schematic.pdf”) inside the EVM_Related folder on the supplied CD.

IMPORTANT NOTICE

Texas Instruments Incorporated and its subsidiaries (TI) reserve the right to make corrections, modifications, enhancements, improvements, and other changes to its products and services at any time and to discontinue any product or service without notice. Customers should obtain the latest relevant information before placing orders and should verify that such information is current and complete. All products are sold subject to TI's terms and conditions of sale supplied at the time of order acknowledgment.

TI warrants performance of its hardware products to the specifications applicable at the time of sale in accordance with TI's standard warranty. Testing and other quality control techniques are used to the extent TI deems necessary to support this warranty. Except where mandated by government requirements, testing of all parameters of each product is not necessarily performed.

TI assumes no liability for applications assistance or customer product design. Customers are responsible for their products and applications using TI components. To minimize the risks associated with customer products and applications, customers should provide adequate design and operating safeguards.

TI does not warrant or represent that any license, either express or implied, is granted under any TI patent right, copyright, mask work right, or other TI intellectual property right relating to any combination, machine, or process in which TI products or services are used. Information published by TI regarding third-party products or services does not constitute a license from TI to use such products or services or a warranty or endorsement thereof. Use of such information may require a license from a third party under the patents or other intellectual property of the third party, or a license from TI under the patents or other intellectual property of TI.

Reproduction of TI information in TI data books or data sheets is permissible only if reproduction is without alteration and is accompanied by all associated warranties, conditions, limitations, and notices. Reproduction of this information with alteration is an unfair and deceptive business practice. TI is not responsible or liable for such altered documentation. Information of third parties may be subject to additional restrictions.

Resale of TI products or services with statements different from or beyond the parameters stated by TI for that product or service voids all express and any implied warranties for the associated TI product or service and is an unfair and deceptive business practice. TI is not responsible or liable for any such statements.

TI products are not authorized for use in safety-critical applications (such as life support) where a failure of the TI product would reasonably be expected to cause severe personal injury or death, unless officers of the parties have executed an agreement specifically governing such use. Buyers represent that they have all necessary expertise in the safety and regulatory ramifications of their applications, and acknowledge and agree that they are solely responsible for all legal, regulatory and safety-related requirements concerning their products and any use of TI products in such safety-critical applications, notwithstanding any applications-related information or support that may be provided by TI. Further, Buyers must fully indemnify TI and its representatives against any damages arising out of the use of TI products in such safety-critical applications.

TI products are neither designed nor intended for use in military/aerospace applications or environments unless the TI products are specifically designated by TI as military-grade or "enhanced plastic." Only products designated by TI as military-grade meet military specifications. Buyers acknowledge and agree that any such use of TI products which TI has not designated as military-grade is solely at the Buyer's risk, and that they are solely responsible for compliance with all legal and regulatory requirements in connection with such use.

TI products are neither designed nor intended for use in automotive applications or environments unless the specific TI products are designated by TI as compliant with ISO/TS 16949 requirements. Buyers acknowledge and agree that, if they use any non-designated products in automotive applications, TI will not be responsible for any failure to meet such requirements.

Following are URLs where you can obtain information on other Texas Instruments products and application solutions:

Products

Audio	www.ti.com/audio
Amplifiers	amplifier.ti.com
Data Converters	dataconverter.ti.com
DLP® Products	www.dlp.com
DSP	dsp.ti.com
Clocks and Timers	www.ti.com/clocks
Interface	interface.ti.com
Logic	logic.ti.com
Power Mgmt	power.ti.com
Microcontrollers	microcontroller.ti.com
RFID	www.ti-rfid.com
RF/IF and ZigBee® Solutions	www.ti.com/lprf

Applications

Communications and Telecom	www.ti.com/communications
Computers and Peripherals	www.ti.com/computers
Consumer Electronics	www.ti.com/consumer-apps
Energy and Lighting	www.ti.com/energy
Industrial	www.ti.com/industrial
Medical	www.ti.com/medical
Security	www.ti.com/security
Space, Avionics and Defense	www.ti.com/space-avionics-defense
Transportation and Automotive	www.ti.com/automotive
Video and Imaging	www.ti.com/video
Wireless	www.ti.com/wireless-apps

TI E2E Community Home Page

e2e.ti.com

Mailing Address: Texas Instruments, Post Office Box 655303, Dallas, Texas 75265
Copyright © 2011, Texas Instruments Incorporated