

DETAIL C  
SCALE 2:1

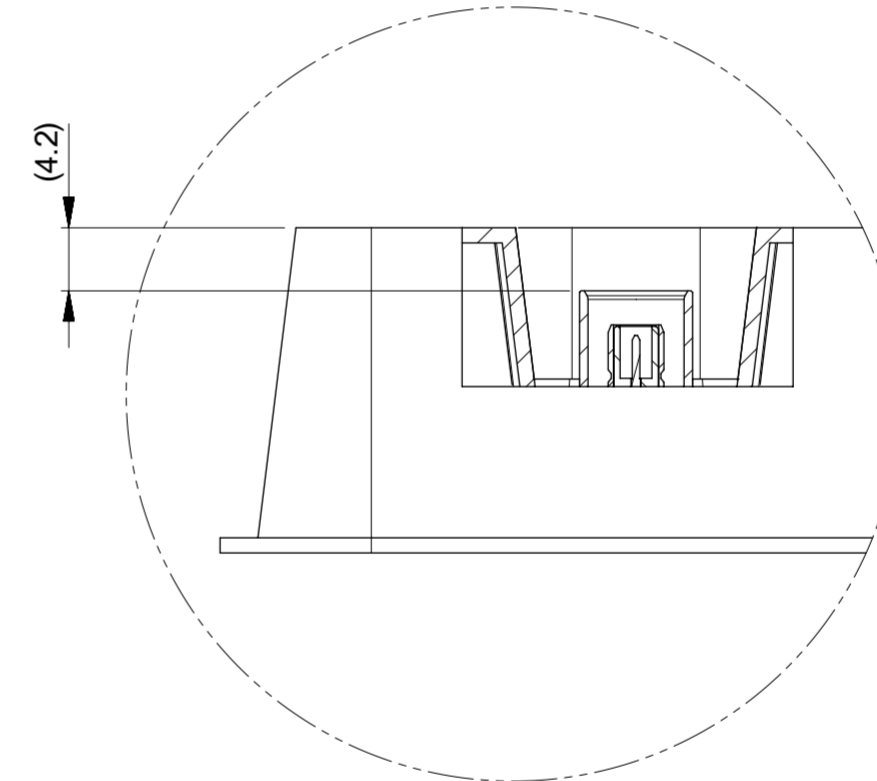

DETAIL F  
SCALE 2:1

NOTES:

1. 一般公差 : ±0.5  
GENERAL TOLERANCE: ±0.5
2. 反り・ねじれを含む全高は23.5 MAX.とする。  
TOTAL HEIGHT INCLUDING WARP, TWIST SHALL BE 23.5 MAX.
3. 材料 : ポリスチレンシート 透明 t=1.0  
MATERIAL : POLYSTYRENE SHEET TRANSPARENCY t=1.0
4. 梱包数 : 120個  
PACKAGING QUANTITY: 120pcs.

N	PASTEL GREEN	N/A
M	PASTEL ORANGE	2011260113
L	CARMINE RED	N/A
Z	WATER BLUE	2011260111
K	CURRY YELLOW	2011260110
I	BEIGE	2011260109
H	VIOLET	2011260108
G	GRAY	N/A
F	BROWN	2011260106
E	GREEN	2011260105
D	BORDEAUX VIOLET	2011260104
C	BLUE	2011260103
B	CREAM WHITE	2011260102
A	BLACK	2011260101
KEYING CODE	COLOR	TRAY PACKAGE
		オーダー番号 ORDER NO.

THIS DRAWING CONTAINS INFORMATION THAT IS PROPRIETARY TO MOLEX ELECTRONIC TECHNOLOGIES, LLC AND SHOULD NOT BE USED WITHOUT WRITTEN PERMISSION

DIMENSION UNITS	SCALE	CURRENT REV DESC:	
mm	1:2		
GENERAL TOLERANCES (UNLESS SPECIFIED)		EC NO: 601011	
ANGULAR TOL ± 3.0°		DRWN: MYOSHIDA	2018/07/04
4 PLACES ± 0.2		CHK'D: YMIKI01	2018/10/01
3 PLACES ± 0.2		APPR: TOSADA	2018/10/02
2 PLACES ± 0.2		INITIAL REVISION:	
1 PLACE ± 0.25		DRWN: YTOKUZONO	2017/05/15
0 PLACES ± 0.3		APPR: MSASAO	2017/05/19
DRAFT WHERE APPLICABLE MUST REMAIN WITHIN DIMENSIONS		THIRD ANGLE PROJECTION	DRAWING
		SERIES	MATERIAL NUMBER
		A2-SIZE	201126
		SEE CHART	CUSTOMER
		GENERAL	SHEET NUMBER
			1 OF 1

**molex**

FAKRA JACK VERTICAL TRAY PKG

PRODUCT CUSTOMER DRAWING

DOCUMENT NUMBER DOC TYPE DOC PART REVISION

2011260100 PSD 000 A1



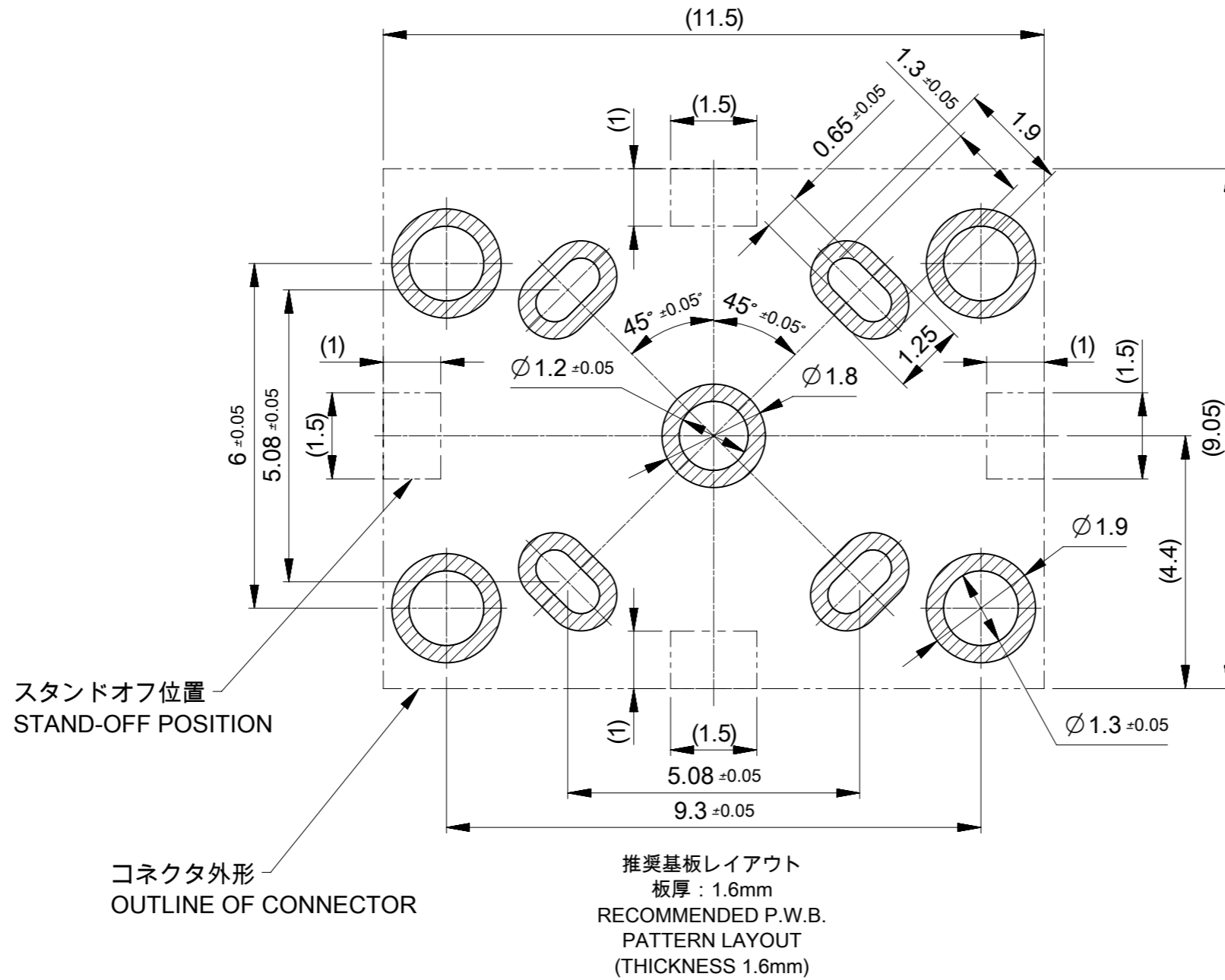

THIS DRAWING CONTAINS INFORMATION THAT IS PROPRIETARY TO MOLEX ELECTRONIC TECHNOLOGIES, LLC AND SHOULD NOT BE USED WITHOUT WRITTEN PERMISSION											
DIMENSION UNITS	SCALE	CURRENT REV DESC: PROPOSED									
mm	1:1										
GENERAL TOLERANCES (UNLESS SPECIFIED)					FAKRA JACK VERTICAL ASSY						
ANGULAR TOL	± 3.0°	EC NO: 601011			PRODUCT CUSTOMER DRAWING						
4 PLACES	± 0.1	DRWN: YMIKI01 2017/04/03			DOCUMENT NUMBER						
3 PLACES	± 0.1	CHK'D: YMIKI01 2018/10/01			2011261100						
2 PLACES	± 0.1	APPR: TOSADA 2018/10/02			DOC TYPE						
1 PLACE	± 0.1	INITIAL REVISION:			PSD						
0 PLACES	± 0.2	DRWN: YMIKI01 2017/04/03			DOC PART						
DRAFT WHERE APPLICABLE MUST REMAIN WITHIN DIMENSIONS		THIRD ANGLE PROJECTION		DRAWING		SERIES		MATERIAL NUMBER		CUSTOMER	SHEET NUMBER
				A3-SIZE		201126		SEE CHART		GENERAL	2 OF 3

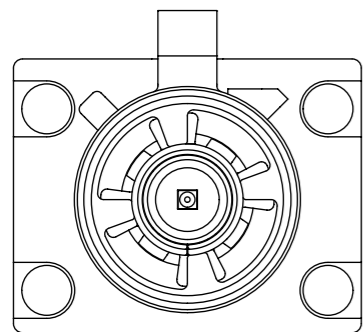

CODE-A

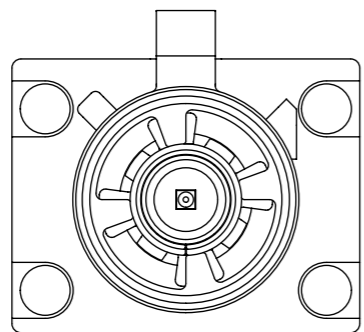

CODE-B

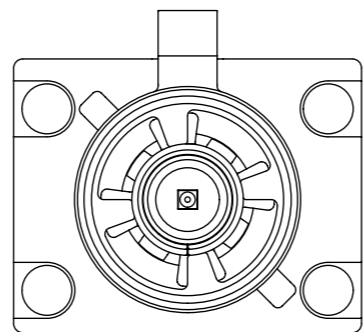

CODE-C

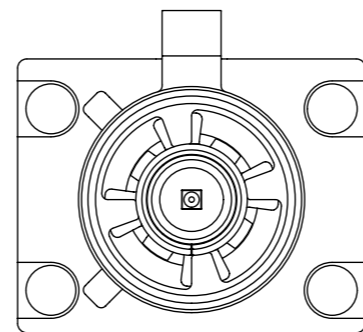

CODE-D

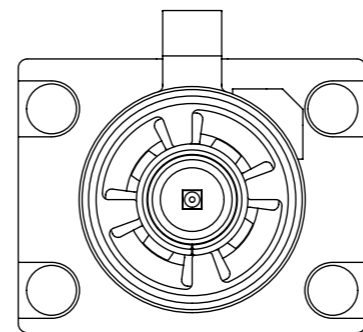

CODE-E

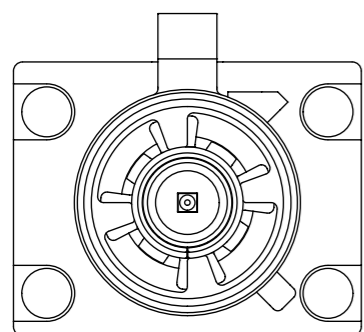

CODE-F

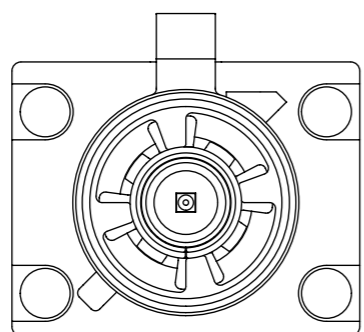

CODE-G

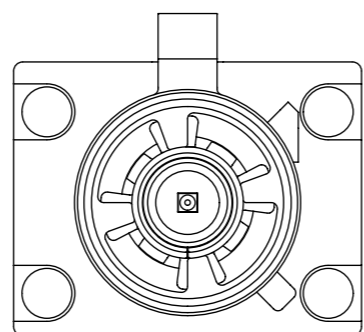

CODE-H

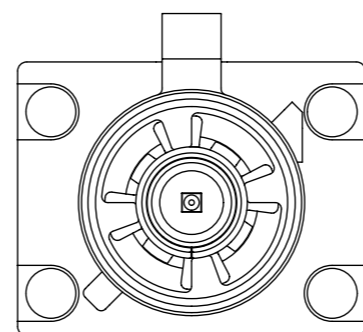

CODE-I

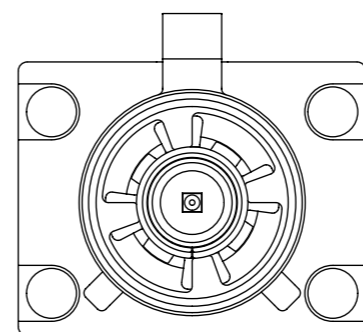

CODE-K

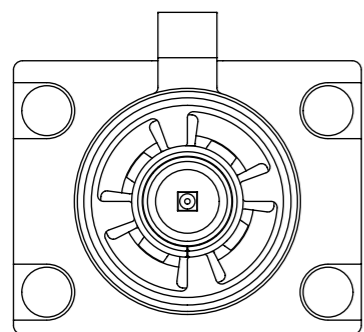

CODE-Z

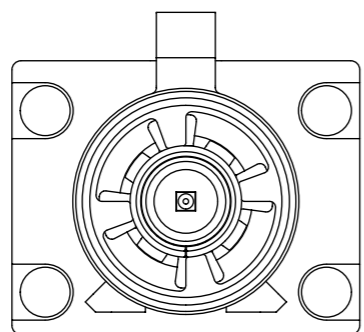

CODE-L

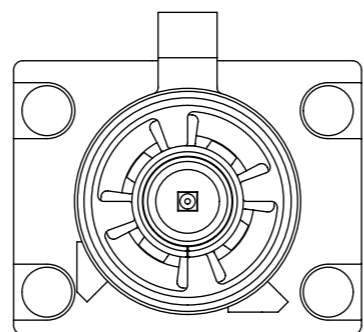

CODE-M

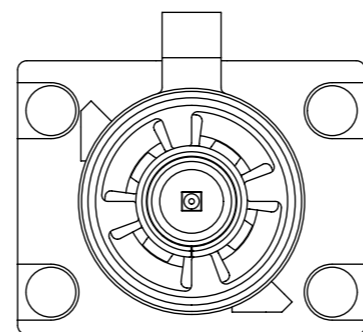

CODE-N

N	PASTEL GREEN	20112611**	N/A
M	PASTEL ORANGE		2011260113
L	CARMINE RED		N/A
Z	WATER BLUE		2011260111
K	CURRY YELLOW		2011260110
I	BEIGE		2011260109
H	VIOLET		2011260108
G	GRAY		N/A
F	BROWN		2011260106
E	GREEN		2011260105
D	BORDEAUX VIOLET		2011260104
C	BLUE		2011260103
B	CREAM WHITE		2011260102
A	BLACK		2011260101
KEYING CODE	COLOR	CONNECTOR SERIES No.	TRAY PACKAGE オーダー番号 ORDER NO.

THIS DRAWING CONTAINS INFORMATION THAT IS PROPRIETARY TO MOLEX ELECTRONIC TECHNOLOGIES, LLC AND SHOULD NOT BE USED WITHOUT WRITTEN PERMISSION

DIMENSION UNITS	SCALE	CURRENT REV DESC: PROPOSED					
mm	5:1	 <b>FAKRA JACK VERTICAL ASSY</b> PRODUCT CUSTOMER DRAWING					
GENERAL TOLERANCES (UNLESS SPECIFIED)							
ANGULAR TOL	± 3.0°						
4 PLACES	± 0.1						
3 PLACES	± 0.1						
2 PLACES	± 0.1						
1 PLACE	± 0.1						
0 PLACES	± 0.2						
DRAFT WHERE APPLICABLE MUST REMAIN WITHIN DIMENSIONS		THIRD ANGLE PROJECTION	DRAWING	SERIES	MATERIAL NUMBER	CUSTOMER	SHEET NUMBER
			A3-SIZE	201126	SEE CHART	GENERAL	3 OF 3

EC NO: 601011  
 DRWN: YMIKI01 2017/04/03  
 CHK'D: YMIKI01 2018/10/01  
 APPR: TOSADA 2018/10/02

INITIAL REVISION:  
 DRWN: YMIKI01 2017/04/03  
 APPR: TOSADA 2018/10/02

DOCUMENT NUMBER: 2011261100  
 DOC TYPE: PSD  
 DOC PART: 000  
 REVISION: A