

Low-Power Headset Detection IC in Miniaturized Package

Description

The AZV5001 is a low-power and cost-effective headset detection IC containing a comparator with internal hysteresis, OR gate, and N-channel integrated MOSFET, designed to detect the insertion of a headset with a microphone.

Pull-up resistors for the detection pins are internalized; a built-in resistor divider provides the reference voltage for detecting the left audio channel. The logic low output of the OR gate indicates the headset is connected properly.

The AZV5001 is available in a miniaturized DFN1210-6 package, which helps reduce the space needed on PCB boards.

Pin Assignments

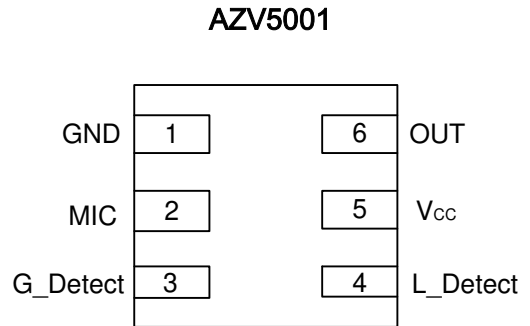

**Top View
(DFN1210-6)**

Figure 1

Features

- Low Supply Current: 7.5µA(typical) @ V_{CC} = 1.8V
- Supply Voltage Range: 1.6~5.0V
- Comparator, OR Gate, N-Channel MOSFET Integrated
- Open Drain Output for MIC Pin
- DFN1210-6: Available in "Green" Molding Compound (No Br. Sb.)
- **Totally Lead-Free & Fully RoHS Compliant (Notes 1 & 2)**
- **Halogen and Antimony Free. "Green" Device (Note 3)**

Notes:

1. No purposely added lead. Fully EU Directive 2002/95/EC (RoHS) & 2011/65/EU (RoHS 2) compliant.
2. See http://www.diodes.com/quality/lead_free.html for more information about Diodes Incorporated's definitions of Halogen- and Antimony-free, "Green" and Lead-free.
3. Halogen- and Antimony-free "Green" products are defined as those which contain <900ppm bromine, <900ppm chlorine (<1500ppm total Br + Cl) and <1000ppm antimony compounds.

Applications

- Mobile Phones
- Tablets
- Battery Powered Devices
- Alarm and Security Systems

Ordering Information

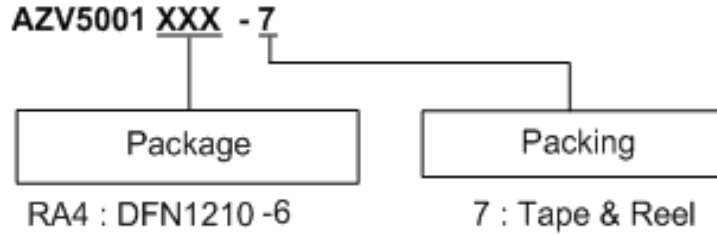

Part Number	Package Code	Packaging	7" Tape and Reel	
			Quantity	Part Number Suffix
AZV5001RA4-7	RA4	X2-DFN1210-6	5,000/Tape & Reel	-7

Marking Information

(1) DFN1210-6

(Top View)

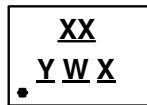

- XX : Identification Code
- Y : Year : 0~9
- W : Week : A~Z : 1~26 week;
a~z : 27~52 week; z represents 52 and 53 week
- X : Internal Code

Part Number	Package	Identification Code
AZV5001RA4-7	X2-DFN1210-6	XE

Typical Applications Circuit

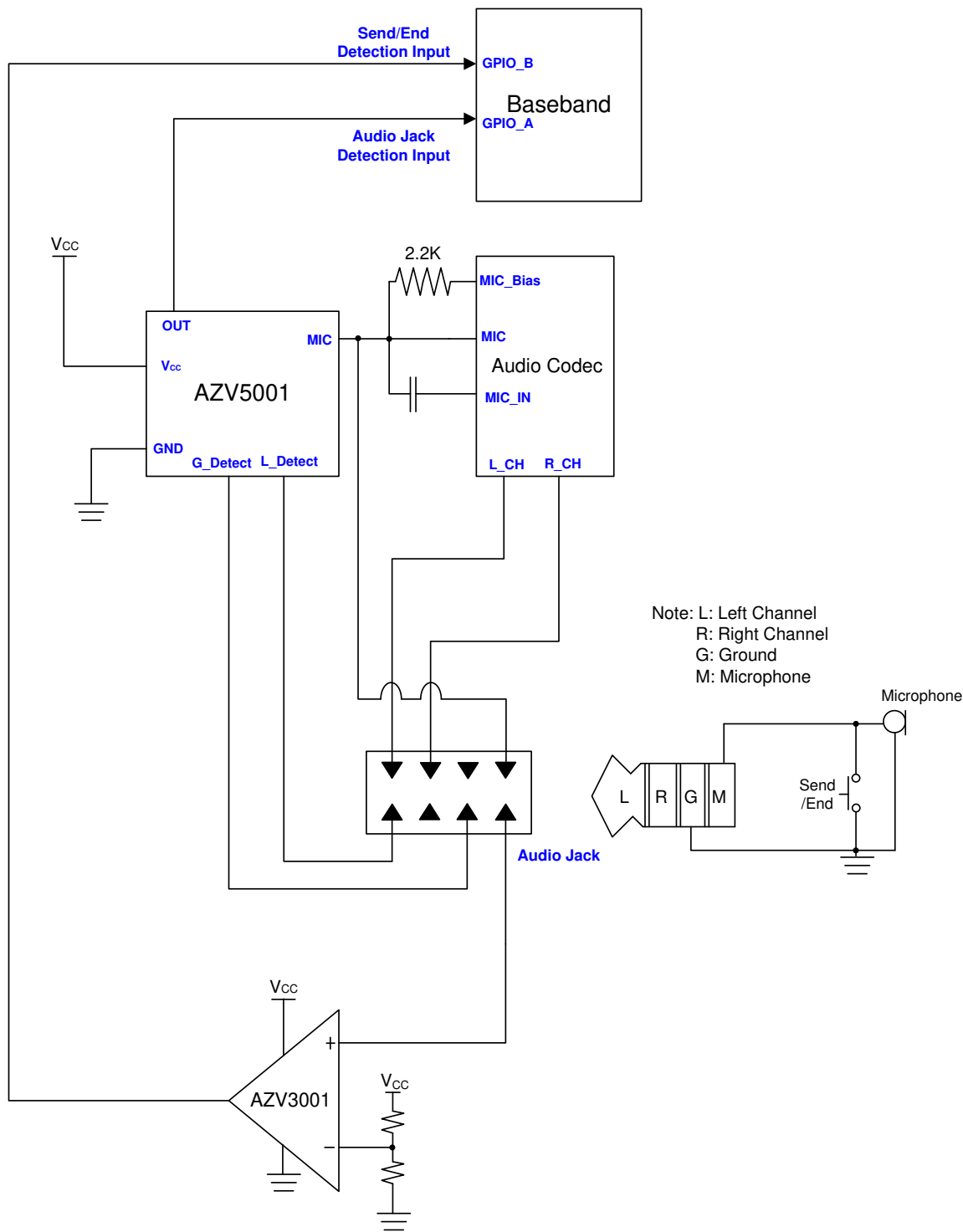

Figure 2

Functional Block Diagram

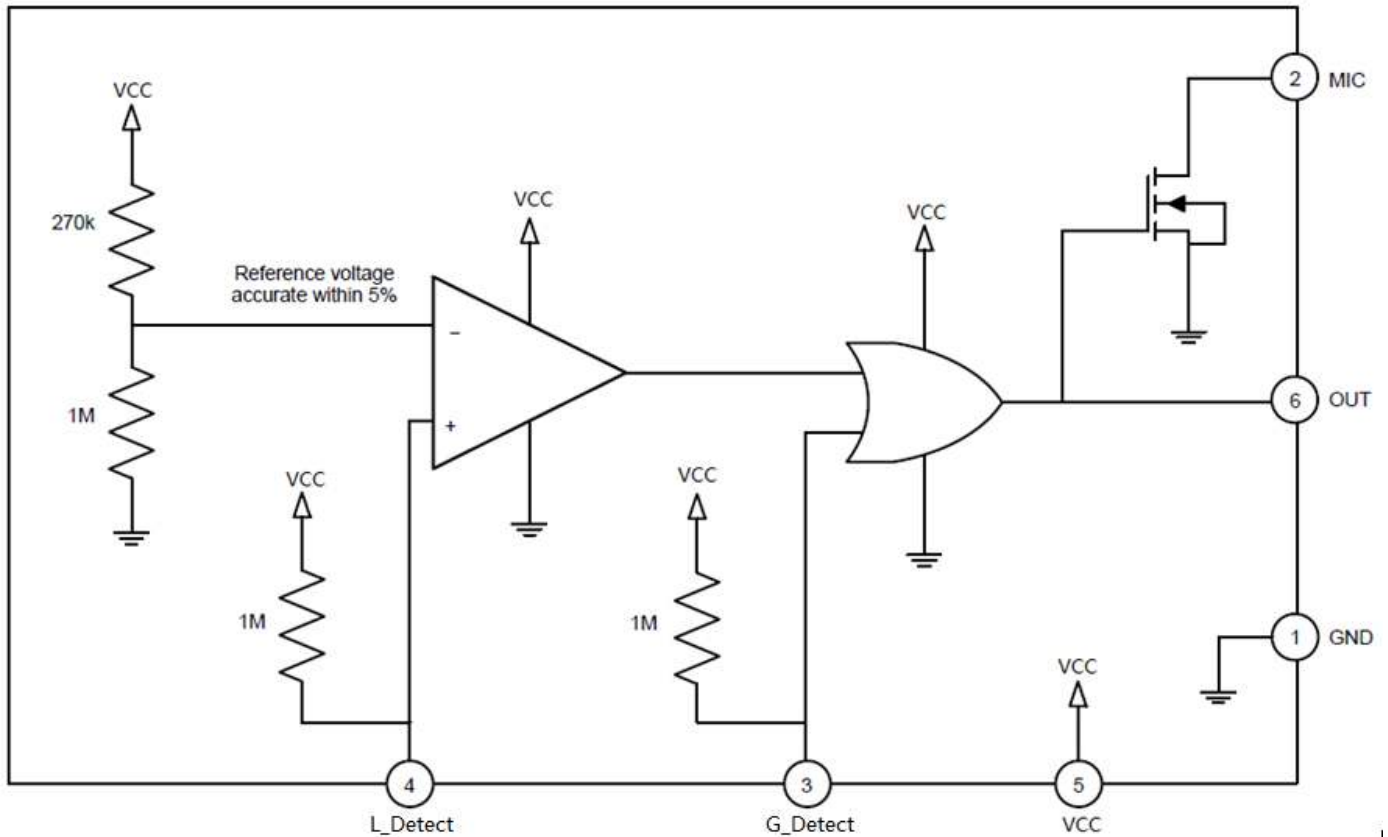

Figure 3

Pin Descriptions

AZV5001		
Pin Name	Pin Number	Function
GND	1	Negative power supply pin; this pin is connected to the system ground
MIC	2	MIC output pin with open drain output type; When the headset is asserted, then MIC is pulled up to the MIC bias voltage with a pull-up resistor. When the headset is not asserted, then MIC is pulled low.
G_Detect	3	Ground detection pin
L_Detect	4	Left channel detection pin
Vcc	5	Positive Power Supply Pin, which pin is connected with system power supply. A minimum 0.1µF decoupling capacitor is recommended as close as possible to this VCC pin.
OUT	6	OUT is a logic output that indicates whether the headset has been properly connected. OUT will be logic low only when G_detect and L_detect are low. Table 3.

Output Logic

Inputs		Outputs		Headset
L_Detect	G_Detect	OUT	MIC	-
0	0	0	1 (External Pull-Up)	Detected
0	1	1	0	Not Detected
1	0	1	0	Not Detected
1	1	1	0	Not Detected

Absolute Maximum Ratings (@T_A = +25°C, unless otherwise specified.)

Symbol	Parameter	Conditions	Min	Max	Unit
V _{CC}	Supply Voltage	-	0	5.5	V
V _{MIC}	MIC Pin Supply Voltage Range	-	0	5.5	V
I _{MIC}	Maximum MIC Pin Current	-	-	2	mA
V _{G_Detect}	G_Detect Pin Input Voltage Range	-	-0.1	V _{CC} +0.1	V
V _{L_Detect}	L_Detect Pin Input Voltage Range	-	-0.1	V _{CC} +0.1	V
T _{j(max)}	Maximum Junction Temperature	-	-	+150	°C
T _{STG}	Storage Temperature	-	-65	+150	°C
ESD	HBM	-	4,000		v
I _{Latch-up}	Latch-Up Current	-	200		mA
P _{TOT}	Total Power Dissipation	-	-	TBD	mW

Recommended Operating Conditions (@T_A = +25°C, unless otherwise specified.)

Symbol	Parameter	Min	Max	Unit
V _{CC}	Supply Voltage	1.6	5.0	V
V _{MIC}	MIC Pin Supply Voltage Range	1.6	5.0	V
V _{IN}	Input Voltage of L_Detect and G_Detect pins	0	5.0	V
Δt/ΔV	Input Transient Rise or Fall Rate	0	10	ns/V
T _A	Ambient Operating Temperature Range	-40	+85	°C

Electrical Characteristics (@ $T_A=+25^{\circ}\text{C}$, $V_{CC}=1.8\text{V}$, $V_{CM}=0.5V_{CC}$, unless otherwise specified.)

Symbol	Parameter	Conditions	+25°C			Units
			Min	Typ	Max	
I_{CC}	Supply Current	$V_{G_Detect} = 1.8\text{V or } 0\text{V}$	-	7.5	12	μA
Input Characteristics of L_Detect						
V_{IH}	Input Logic High	$V_{CC} = 1.8\text{V}$	1.5	-	-	V
V_{IL}	Input Logic Low	$V_{CC} = 1.8\text{V}$	-	-	1.33	V
t_{pLH}, t_{pHL}	Propagation Delay	$C_{out} = 15\text{pF}, G_Detect = 0\text{V},$ $L_Detect = 1.31\sim 1.52\text{V}$	-	480	-	ns
C_{IN}	Input Capacitance	$f = 1\text{MHz}$	-	3	-	pF
I_{IH}	Low Voltage Input Leakage	$V_{L_Detect} = 0\text{V}$	-	1.8	-	μA
I_{IL}	High Voltage Input Leakage	$V_{L_Detect} = 1.8\text{V}$	-	0.5	-	nA
Input Characteristics of G_Detect						
V_{IH}	Input Logic High	$V_{CC} = 1.8\text{V}$	1.17	-	-	V
V_{IL}	Input Logic Low	$V_{CC} = 1.8\text{V}$	-	-	0.63	V
t_{pLH}, t_{pHL}	Propagation Delay	$C_{out} = 15\text{pF}, L_Detect = 0\text{V},$ $G_Detect = 0\sim 1.8\text{V}$	-	10	-	ns
C_{IN}	Input Capacitance	$f = 1\text{MHz}$	-	3	-	pF
I_{IH}	Low Voltage Input Leakage	$V_{L_Detect} = 0\text{V}$	-	1.8	-	μA
I_{IL}	High Voltage Input Leakage	$V_{L_Detect} = 1.8\text{V}$	-	0.5	-	nA
Output Characteristics of OUT						
V_{OH}	Output Logic High	$V_{CC} = 1.8\text{V}, I_{OH} = -0.1\text{mA}$	1.7	-	-	V
V_{OL}	Output Logic Low	$V_{CC} = 1.8\text{V}, I_{OH} = 0.1\text{mA}$	-	-	0.1	V
T_{rise}	Rise Time	$C_{OUT} = 15\text{pF}, R_L = 1\text{M}\Omega$	-	7	-	ns
T_{fall}	Fall Time	$C_{OUT} = 15\text{pF}, R_L = 1\text{M}\Omega$	-	4	-	ns
Characteristics of MIC Pin						
$R_{DS(on)}$	Drain-Source On Resistor of NMOS	$V_{CC} = 1.8\text{V}, I_{MIC} = 1\text{mA}$	-	0.9	1.4	Ω

Performance Characteristics

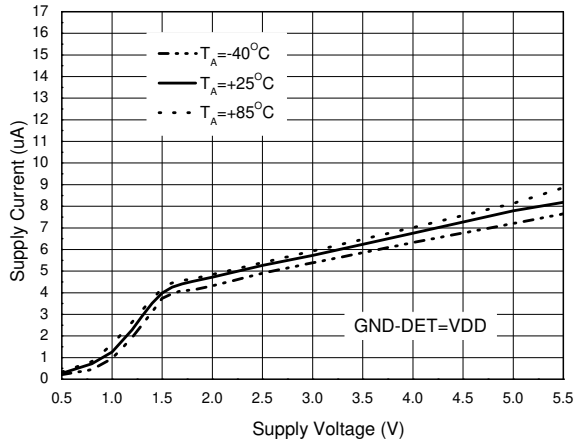

Supply Current vs. Supply Voltage

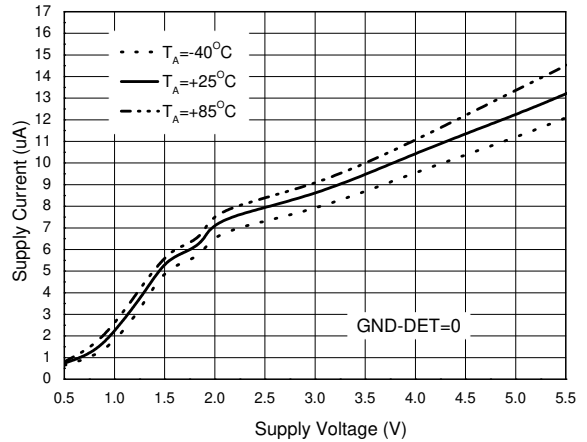

Supply Current vs. Supply Voltage

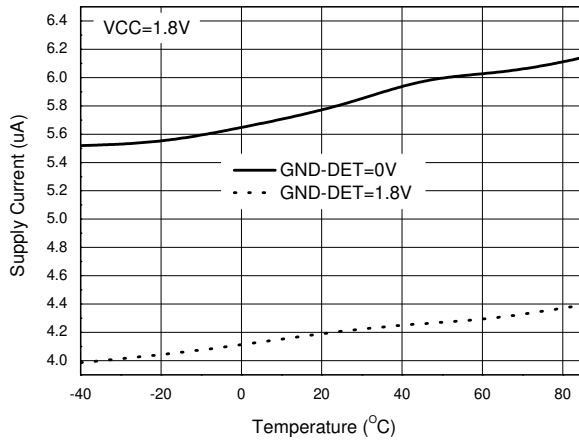

Supply Current vs. Temperature

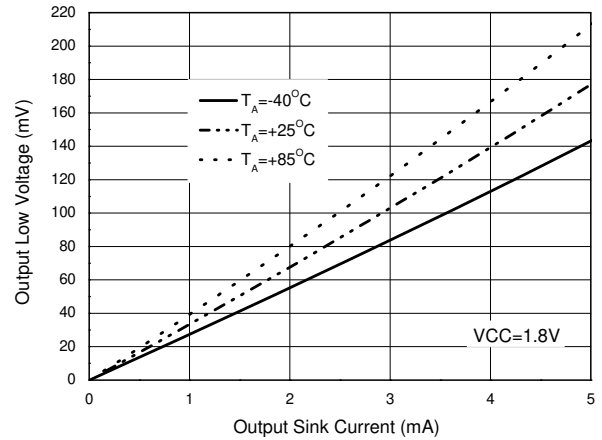

Output Low Voltage Characteristics

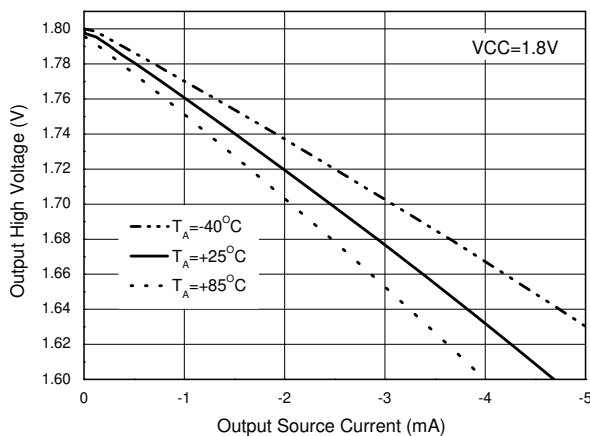

Output High-Voltage Characteristics

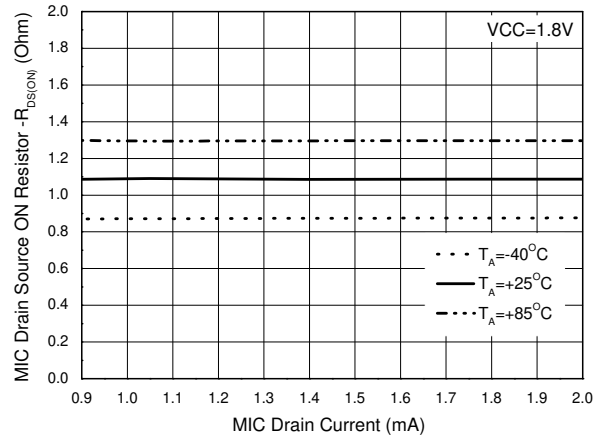

MIC ON Resistor vs. Drain Current

Performance Characteristics (continued)

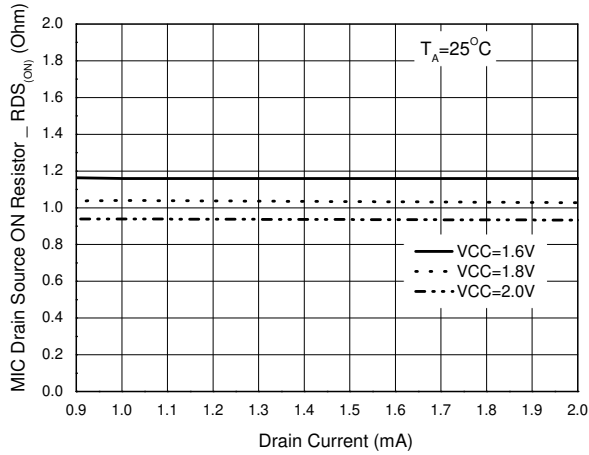

MIC ON Resistor vs. Drain Current

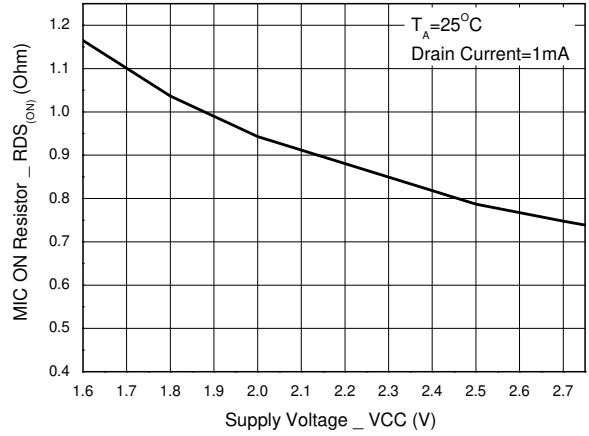

MIC ON Resistor vs. Supply Voltage

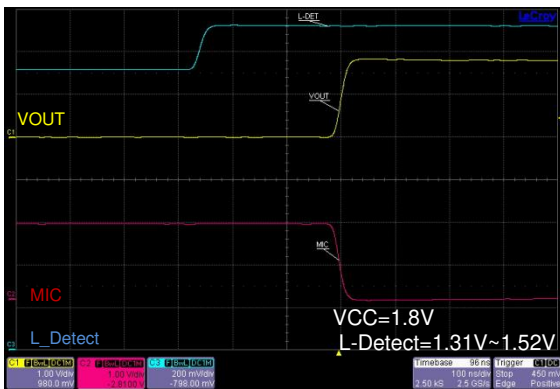

L-DET TO VOUT, MIC Response

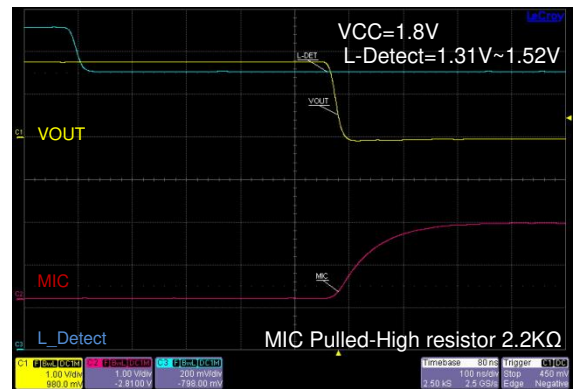

L-DET TO VOUT, MIC Response

Application Information

Supply Voltage

The AZV5001 device is guaranteed to operate at supply voltage ultra low to 1.6V. For better performance, a power supply decoupling capacitor is necessary, a minimum 0.1 μ F decoupling capacitor should be placed as close as possible to the V_{CC} pin.

Audio Jack Detection

The AZV5001 is designed to simplify the detection of stereo audio connector with a microphone contact. When the headset is not connected, the internal pull-up resistors on L_Detect and G_Detect pull those pins high. When the headset is connected to the switched audio jack, the headset ground and left audio channel trigger L_Detect and G_Detect to logic low.

The AZV5001 can work with either the CITA or OMTP standard. In order to support both standards simultaneously, a cross point switch and additional circuitry is necessary to detect and swap the ground and microphone pins.

MIC Pin Biasing

The AZV5001 typical application circuit in Figure 2 shows the recommended 2.2K Ω pull-up resistor to the MIC bias voltage under supply voltage 1.8V condition. While the headset is not detected, the internal NMOS transistor is enabled to mute the MIC signal. If the MIC sink current is 1mA under system application, the MIC pin is pulled near 1mV when the headset is not present. The internal NMOS transistor is optimized to sink up to 2mA of current, allowing some flexibility in the selection of the pull-up resistor and MIC bias voltage.

Package Outline Dimensions (All dimensions in mm.)

Please see AP02002 at <http://www.diodes.com/datasheets/ap02002.pdf> for the latest version.

X2-DFN1210-6

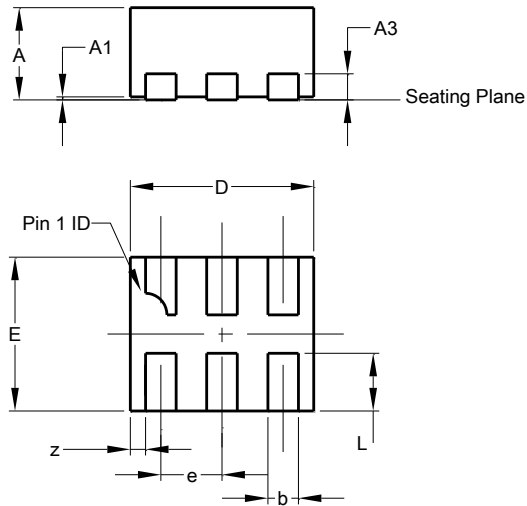

X2-DFN1210-6			
Dim	Min	Max	Typ
A	-	0.40	-
A1	0.00	0.05	0.03
A3	-	-	0.13
b	0.15	0.25	0.20
D	1.15	1.275	1.20
E	0.95	1.075	1.00
e	-	-	0.40
L	0.325	0.425	0.375
z	-	-	0.100
All Dimensions in mm			

Suggested Pad Layout

Please see AP02001 at <http://www.diodes.com/datasheets/ap02001.pdf> for the latest version.

X2-DFN1210-6

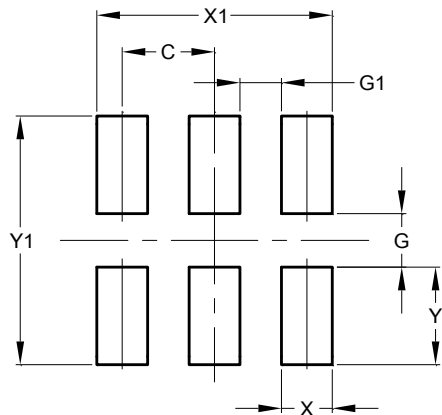

Dimensions	Value (in mm)
C	0.400
G	0.230
G1	0.180
X	0.220
X1	1.020
Y	0.420
Y1	1.070

Taping Orientation (Note 4)

X2-DFN1210-6

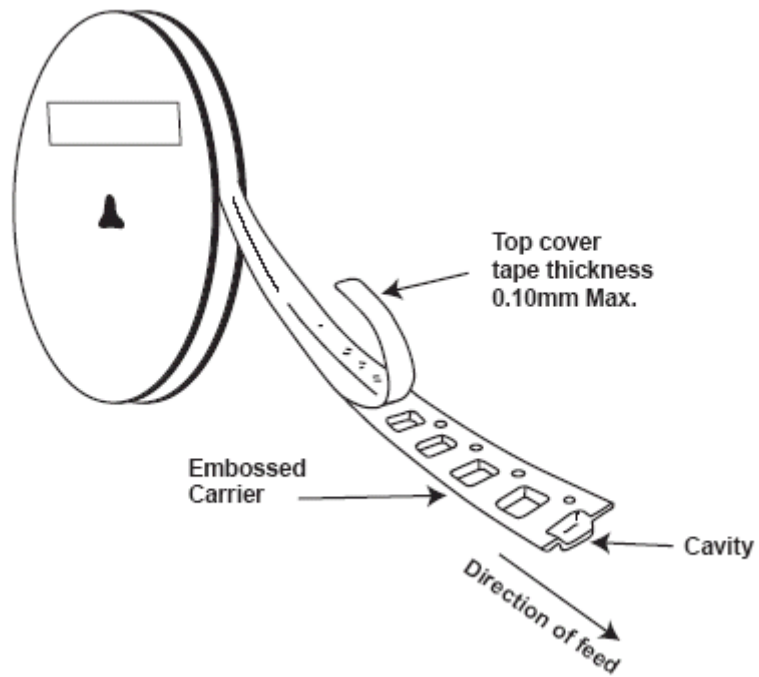
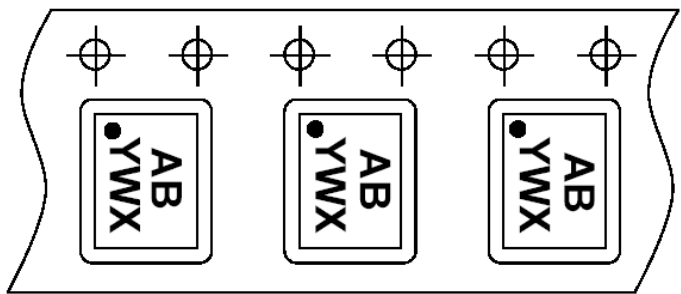

Note: 4. The taping orientation of the other package type can be found on our website at <http://www.diodes.com/datasheets/ap02007.pdf>.

IMPORTANT NOTICE

DIODES INCORPORATED MAKES NO WARRANTY OF ANY KIND, EXPRESS OR IMPLIED, WITH REGARDS TO THIS DOCUMENT, INCLUDING, BUT NOT LIMITED TO, THE IMPLIED WARRANTIES OF MERCHANTABILITY AND FITNESS FOR A PARTICULAR PURPOSE (AND THEIR EQUIVALENTS UNDER THE LAWS OF ANY JURISDICTION).

Diodes Incorporated and its subsidiaries reserve the right to make modifications, enhancements, improvements, corrections or other changes without further notice to this document and any product described herein. Diodes Incorporated does not assume any liability arising out of the application or use of this document or any product described herein; neither does Diodes Incorporated convey any license under its patent or trademark rights, nor the rights of others. Any Customer or user of this document or products described herein in such applications shall assume all risks of such use and will agree to hold Diodes Incorporated and all the companies whose products are represented on Diodes Incorporated website, harmless against all damages.

Diodes Incorporated does not warrant or accept any liability whatsoever in respect of any products purchased through unauthorized sales channel. Should Customers purchase or use Diodes Incorporated products for any unintended or unauthorized application, Customers shall indemnify and hold Diodes Incorporated and its representatives harmless against all claims, damages, expenses, and attorney fees arising out of, directly or indirectly, any claim of personal injury or death associated with such unintended or unauthorized application.

Products described herein may be covered by one or more United States, international or foreign patents pending. Product names and markings noted herein may also be covered by one or more United States, international or foreign trademarks.

This document is written in English but may be translated into multiple languages for reference. Only the English version of this document is the final and determinative format released by Diodes Incorporated.

LIFE SUPPORT

Diodes Incorporated products are specifically not authorized for use as critical components in life support devices or systems without the express written approval of the Chief Executive Officer of Diodes Incorporated. As used herein:

A. Life support devices or systems are devices or systems which:

1. are intended to implant into the body, or
2. support or sustain life and whose failure to perform when properly used in accordance with instructions for use provided in the labeling can be reasonably expected to result in significant injury to the user.

B. A critical component is any component in a life support device or system whose failure to perform can be reasonably expected to cause the failure of the life support device or to affect its safety or effectiveness.

Customers represent that they have all necessary expertise in the safety and regulatory ramifications of their life support devices or systems, and acknowledge and agree that they are solely responsible for all legal, regulatory and safety-related requirements concerning their products and any use of Diodes Incorporated products in such safety-critical, life support devices or systems, notwithstanding any devices- or systems-related information or support that may be provided by Diodes Incorporated. Further, Customers must fully indemnify Diodes Incorporated and its representatives against any damages arising out of the use of Diodes Incorporated products in such safety-critical, life support devices or systems.

Copyright © 2015, Diodes Incorporated

www.diodes.com