

TPS48110Q1EVM: Evaluation Module for Smart High-Side Driver TPS48110-Q1



ABSTRACT

This user's guide describes the evaluation module (EVM) for the TPS48110-Q1 smart high-side driver. The document provides EVM configuration information and test setup details for evaluating the TPS48110-Q1 device. The EVM schematic, board layout, and bill of materials (BOM) are also included.

	Caution	Caution Hot surface. Contact may cause burns. Do not touch!
--	---------	---

Table of Contents

1 Introduction	2
2 Description	2
3 Schematic	3
4 General Configurations	4
5 Test Setup and Procedures	5
6 EVAL Board Assembly Drawings	10
7 Bill of Materials (BoM)	12
8 Revision History	16

List of Figures

Figure 3-1. TPS48110Q1EVM Evaluation Module Schematic.....	3
Figure 5-1. TPS48110Q1EVM Setup with Test Equipment.....	5
Figure 5-2. Start-Up Profile of Bootstrap Voltage for INP = GND.....	6
Figure 5-3. Start-Up Profile of Bootstrap Voltage for INP = HIGH.....	6
Figure 5-4. Turn-ON Response of TPS48110-Q1 for INP -> LOW to HIGH.....	7
Figure 5-5. Turn-OFF Response of TPS48110-Q1 for INP -> HIGH to LOW.....	7
Figure 5-6. Overcurrent Response of TPS48110-Q1 for a Load Step from 2 A to 8 A with 5-A Overcurrent Protection Setting.....	8
Figure 5-7. Auto-Retry Response of TPS48110-Q1 for an Overcurrent Fault.....	8
Figure 5-8. Overvoltage Cutoff Response at 58-V Level of TPS48110-Q1.....	9
Figure 6-1. TPS48110Q1EVM Board (a) Top Assembly (b) Bottom Assembly.....	10
Figure 6-2. TPS48110Q1EVM Board (a) Top Layer (b) Bottom Layer.....	10
Figure 6-3. TPS48110Q1EVM Board (a) Inner Signal Layer (b) Inner Routing Layer.....	11

List of Tables

Table 2-1. TPS48110Q1EVM Evaluation Board Options and Setting.....	2
Table 4-1. Input and Output Connector Functionality.....	4
Table 4-2. Test Points Description.....	4
Table 4-3. Jumper and LED Descriptions.....	4
Table 5-1. Default Jumper Setting for TPS48110Q1EVM Evaluation Board.....	5
Table 7-1. TPS48110Q1EVM Bill of Materials.....	12

Trademarks

All trademarks are the property of their respective owners.

1 Introduction

The TPS48110Q1EVM allows reference circuit evaluation of TI's smart high-side driver TPS48110-Q1. The TPS48110-Q1 has an operating range of 3.5 V–80 V and has strong gate drive strength of 4 A to enable switching parallel MOSFETs in high current designs. The device provides two-level adjustable overcurrent protection with adjustable circuit breaker timer, overvoltage protection, fast short-circuit protection, accurate analog current monitor output, and remote overtemperature protection.

1.1 EVM Features

General TPS48110Q1EVM features include:

- 24-V to 60-V (typical) operation
- 5-A to 50-A adjustable overcurrent protection using on-board jumpers
- Programmable circuit breaker timer
- Load current monitoring output
- Programmable auto-retry and latch options
- LED status indication for overcurrent and overtemperature faults

1.2 EVM Applications

This EVM can be used for the following applications:

- PTC heater
- Power distribution unit
- eCAT heater

2 Description

The TPS48110Q1EVM evaluation board enables evaluation of the TPS48110-Q1 driver from TPS4811x-Q1 family. The input power is applied between connectors T1 and T4 while T2 and T3 provide an output connection to the load. Refer to the schematic in [Figure 3-1](#) and EVM test setup in [Figure 5-1](#).

D4 and D5 provide the fault indication output for the overcurrent and overtemperature faults respectively. Scaled current of the load can be monitored at TP10.

Table 2-1. TPS48110Q1EVM Evaluation Board Options and Setting

Part Number	EVM Function	Vin Range	Vin UVLO	Vin OVP	ENABLE (EN/UVLO)	Overcurrent Protection		Features
						Low Setting	Hi Setting	
TPS48110Q1EVM	Smart high-side driver with protection and diagnostics	24 V to 60 V	24 V	58 V	Active high	5 A	50 A	Overload protection with auto-retry and latch response Overvoltage protection

3 Schematic

Figure 3-1 illustrates the EVM schematic.

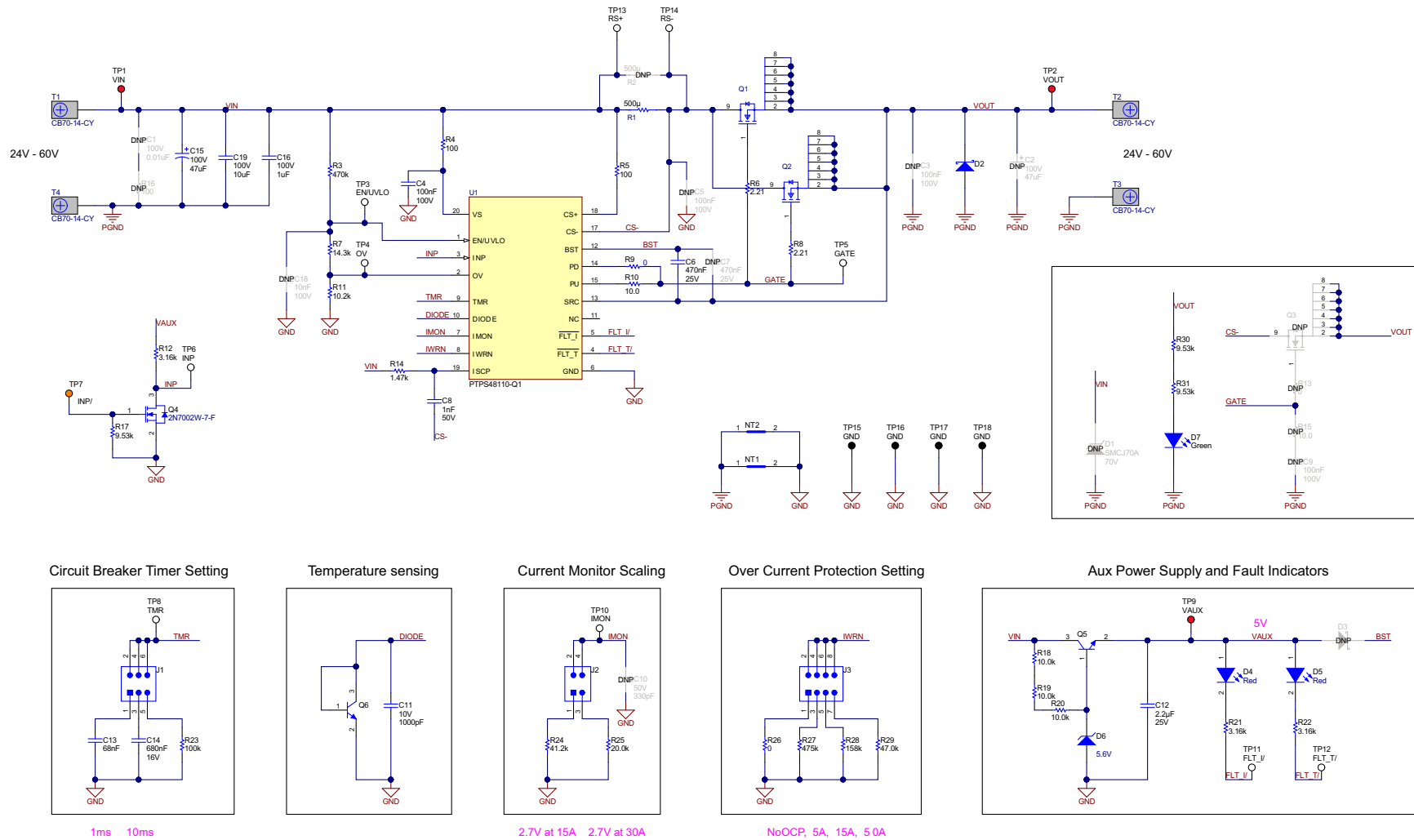

Figure 3-1. TPS48110Q1EVM Evaluation Module Schematic

4 General Configurations

4.1 Physical Access

Table 4-1 lists the TPS48110Q1EVM Evaluation Board input and output connector functionality. Table 4-2 and Table 4-3 describe the test point availability and the jumper functionality.

Table 4-1. Input and Output Connector Functionality

Connector	Label	Description
T1	VIN	Power input connector to the positive rail of the input power supply
T4	PGND	Ground connection for the power supply
T2	VOUT	Power output connector to the positive side of the load
T3	PGND	Ground connection for the load

Table 4-2. Test Points Description

Test Points	Label	Description
TP1	VIN	Input power supply to the EVM
TP2	VOUT	Output from the EVM
TP3	EN/UVLO	Enable control (active high) and undervoltage input
TP4	OV	Overvoltage input
TP5	GATE	GATE of the external main MOSFET
TP6	INP	Control input of main MOSFET
TP7	INP/	Inversion of control input for main MOSFET
TP8	TMR	Fault timer voltage
TP9	VAUX	Auxiliary supply to bias fault LEDs
TP10	IMON	Load current monitor
TP11	FLT_I/	Overcurrent fault output
TP12	FLT_T/	Overtemperature fault output
TP13	RS+	Positive terminal of current sense input
TP14	RS-	Negative terminal of current sense input
TP15, TP16, TP17, TP18	GND	GND

Table 4-3. Jumper and LED Descriptions

Jumper	Label	Description
J1	TMR	Fault timer setting 1-2 position sets 15-ms delay 3-4 position sets 150-ms delay 5-6 position sets the controller in latch-off mode
J2	IMON	Current scale setting 1-2 position sets 0.09 V/A 3-4 position sets 0.034 V/A
J3	IWRN	Overcurrent protection threshold setting 1-2 position sets R_{IWRN} to short and disables the overcurrent protection 3-4 position sets 5 A 5-6 position sets 15 A 7-8 position sets 50 A
D4 (RED – LED)	D4	Fault indicator. LED turns on for overcurrent fault.
D5 (RED – LED)	D5	Fault indicator. LED turns on for overtemperature fault.

4.2 Test Equipment and Setup

4.2.1 Power Supplies

One adjustable power supply with 0-V to 60-V output and 0-A to 50-A output current limit.

4.2.2 Meters

One DMM minimum needed.

4.2.3 Oscilloscope

A DPO2024 or equivalent, three 10 times voltage probes, and a DC current probe.

4.2.4 Loads

One resistive load or equivalent that can tolerate up to 50-A DC load at 60 V and capable of the output short.

5 Test Setup and Procedures

Make sure the evaluation board has default jumper settings as shown in [Table 5-1](#).

Table 5-1. Default Jumper Setting for TPS48110Q1EVM Evaluation Board

J1	J2	J3
1-2	1-2	3-4

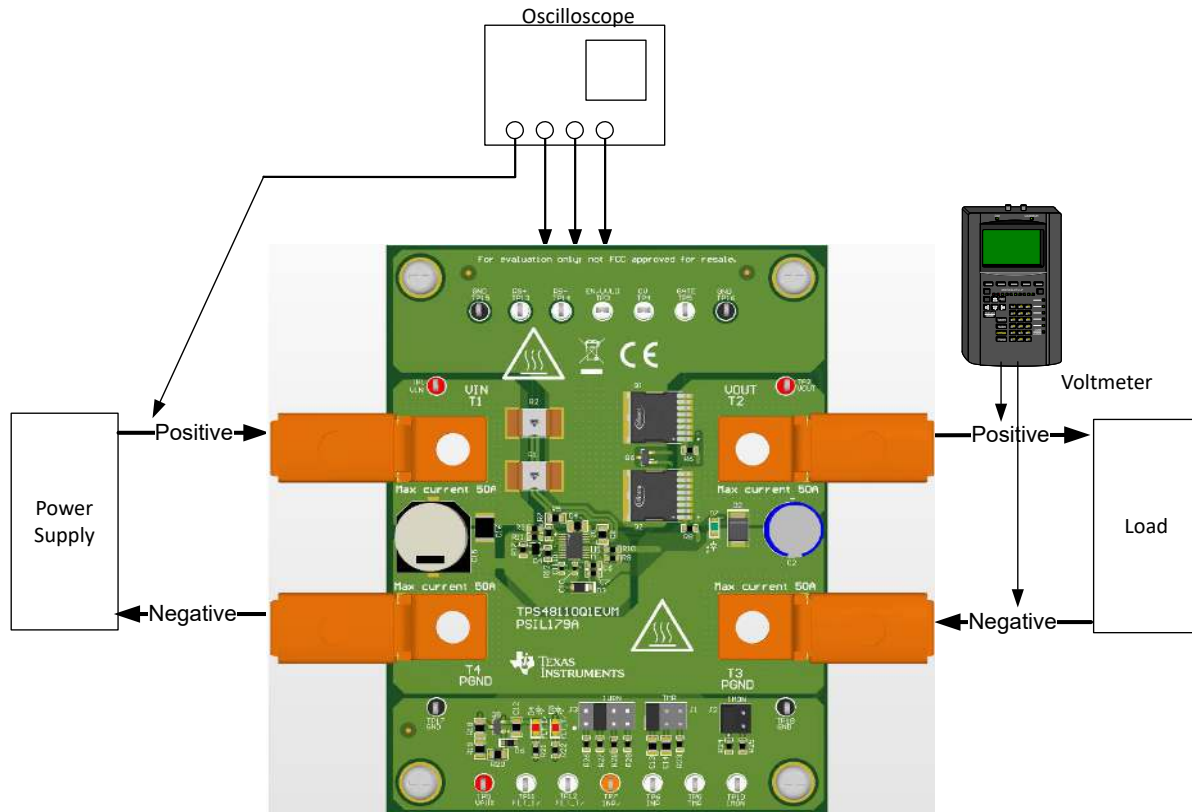

Figure 5-1. TPS48110Q1EVM Setup with Test Equipment

Follow the below instructions before starting any test and repeat again before moving to the next test.

- Set the power supply output (VIN) to zero volts.
- Turn ON the power supply and set the power supply output (VIN) to 48 V, current limit = 50 A.
- Turn OFF the power supply.
- Set the jumper setting on EVM to default position as shown in [Table 5-1](#).

5.1 Power Up with EN Control

Use the following instructions to verify the power-up profile of TPS48110-Q1:

1. Connect the EN/UVLO pin (TP3) to ground and INP (TP6) to ground.
2. Set the input supply voltage VIN to 48 V and current limit of 10 A.
3. Enable the power supply.
4. Now, enable the EN/UVLO to HIGH to observe the start-up profile of BST, GATE and SRC when INP = GND as shown in [Figure 5-2](#).
5. Now, disable the controller by making EN/UVLO = LOW.
6. Connect INP (TP6) to VAUX to set INP as HIGH.
7. Now again, enable the EN/UVLO to HIGH to observe the start-up profile of BST, GATE, and SRC when INP = HIGH as shown in [Figure 5-3](#).

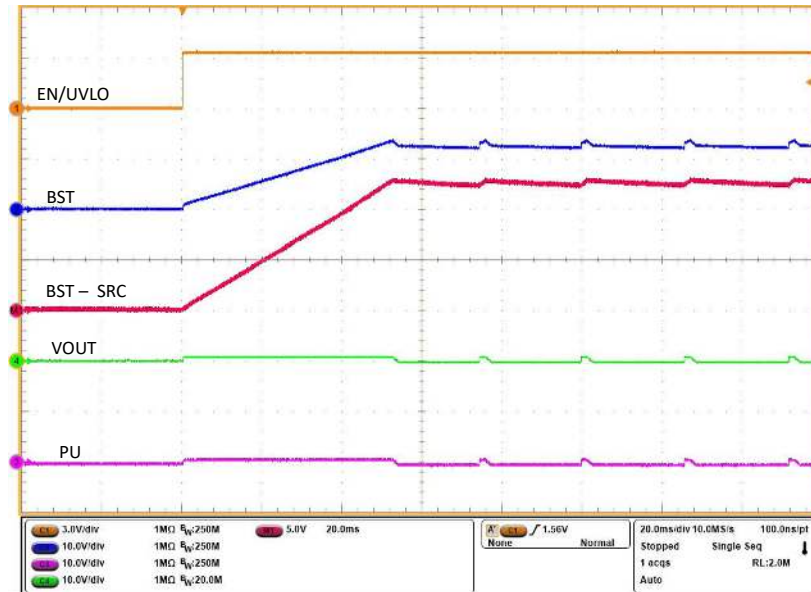

Figure 5-2. Start-Up Profile of Bootstrap Voltage for INP = GND

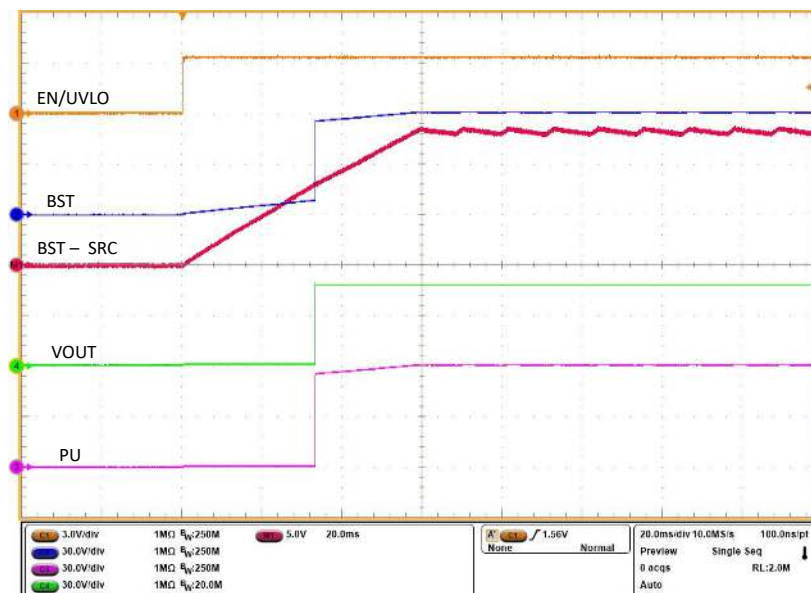

Figure 5-3. Start-Up Profile of Bootstrap Voltage for INP = HIGH

5.2 ON and OFF Control with INP Input

Use the following instructions to verify ON and OFF control of TPS48110-Q1:

1. Connect the INP (TP6) to ground.
2. Set the input supply voltage VIN to 48 V and current limit of 10 A.
3. Enable the power supply.
4. Now, toggle the INP to HIGH and then LOW to verify the turn-ON and turn-OFF response of PU/PD of TPS48110-Q1.

Figure 5-4 and Figure 5-5 show the turn-ON and turn-OFF responses on the TPS48110Q1EVM Evaluation Board.

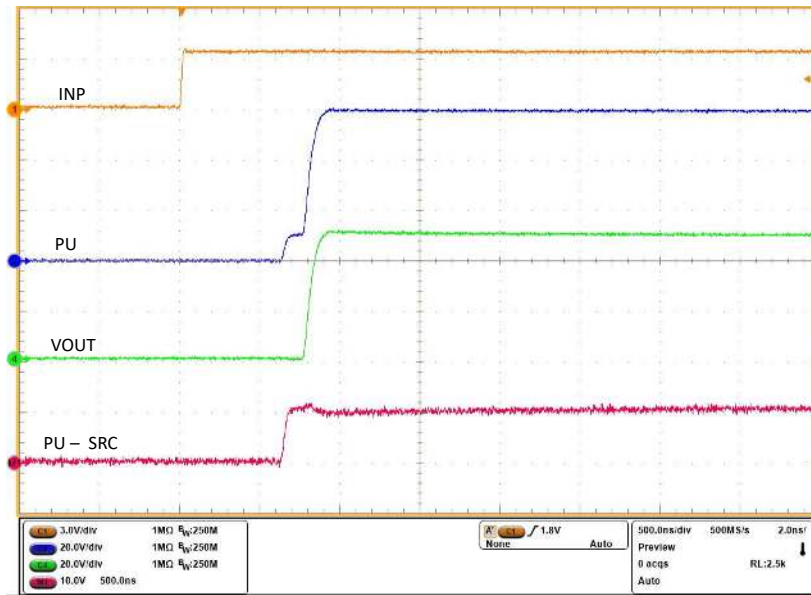

Figure 5-4. Turn-ON Response of TPS48110-Q1 for INP -> LOW to HIGH

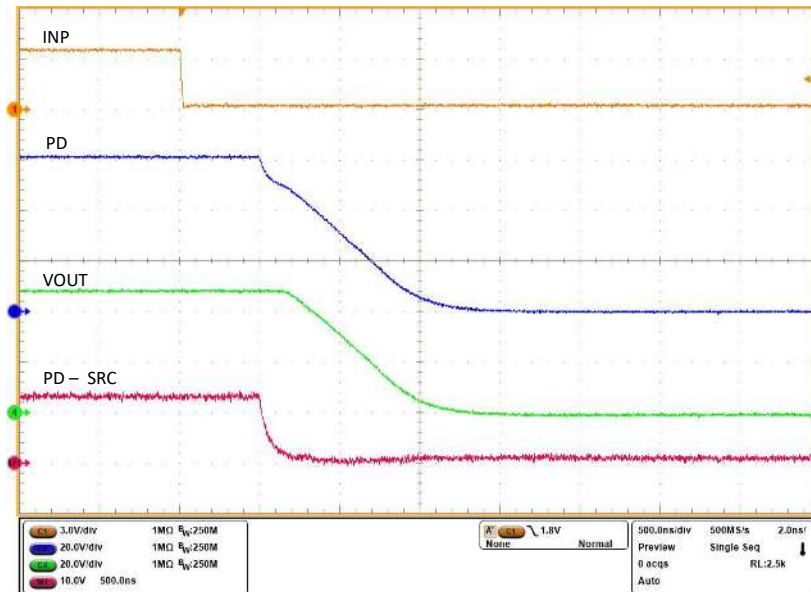

Figure 5-5. Turn-OFF Response of TPS48110-Q1 for INP -> HIGH to LOW

5.3 Overcurrent Protection Test

Use the following instructions to perform the overcurrent test on the TPS48110Q1EVM:

1. Enable the control input INP (TP6) of the main MOSFETS.
2. By default, the EVM is configured for 5-A overcurrent protection.
3. Now, load the output with rheostat or electronic load and gradually increase the load current to observe the overload behavior of TPS48110-Q1.
4. Place jumper J3 at other settings to test at various overcurrent limits.

Figure 5-6 and Figure 5-7 show test waveforms for an overcurrent fault.

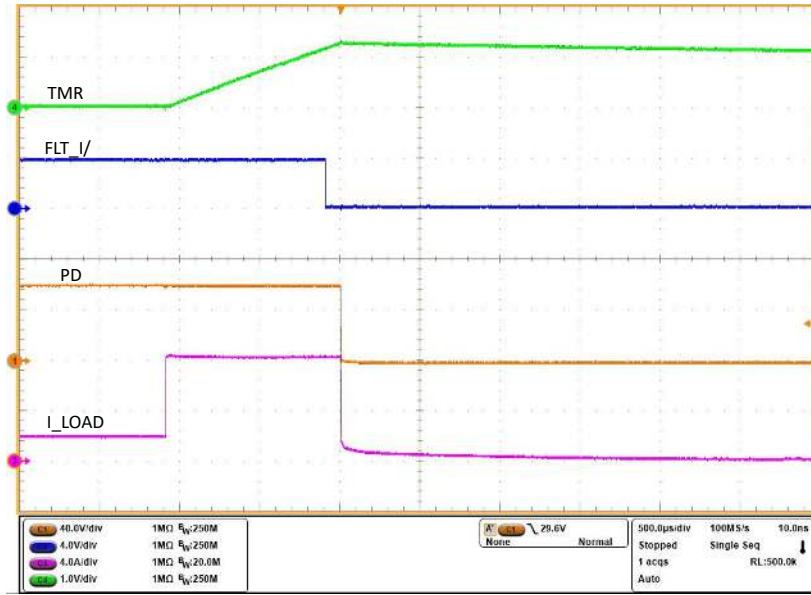

Figure 5-6. Overcurrent Response of TPS48110-Q1 for a Load Step from 2 A to 8 A with 5-A Overcurrent Protection Setting

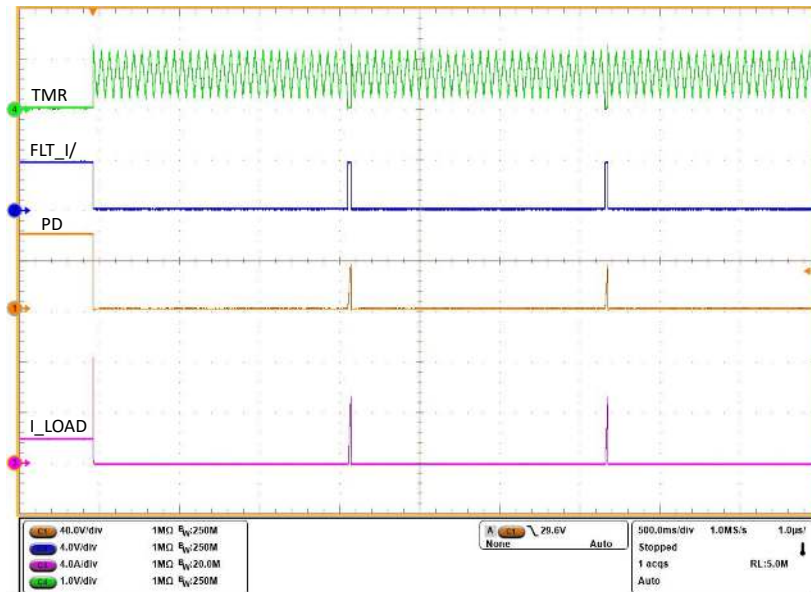

Figure 5-7. Auto-Retry Response of TPS48110-Q1 for an Overcurrent Fault

5.4 Overvoltage Protection Test

Use the following instructions to perform the overvoltage test:

1. Set the input supply voltage V_{IN} to 48 V and current limit of 10 A.
2. Enable the power supply.
3. Now, gradually increase the V_{IN} voltage to observe the overvoltage cutoff response of TPS48110-Q1 using an oscilloscope.

Figure 5-8 shows overvoltage cutoff response of TPS48110-Q1 on TPS48110Q1EVM Evaluation Board.

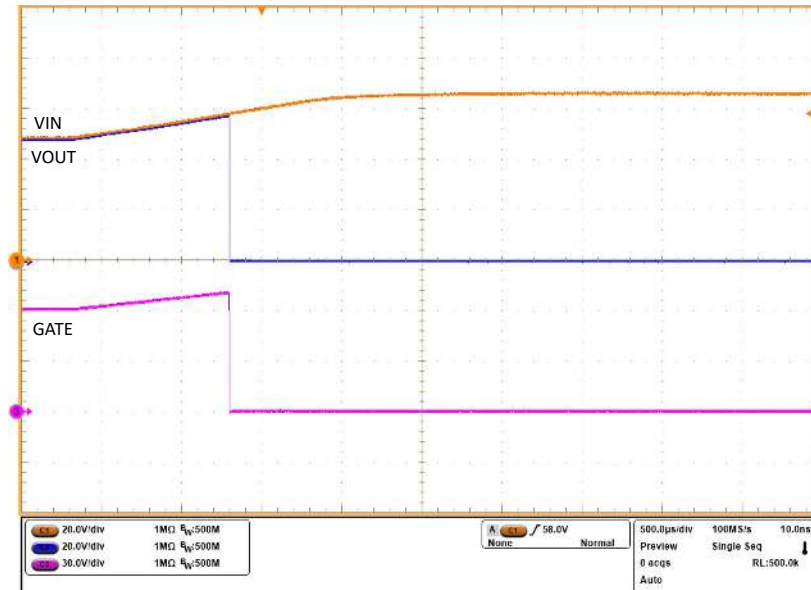

Figure 5-8. Overvoltage Cutoff Response at 58-V Level of TPS48110-Q1

6 EVAL Board Assembly Drawings

6.1 PCB Drawings

Figure 6-1 shows component placement of the EVAL Board, and Figure 6-2 and Figure 6-3 show PCB layout images.

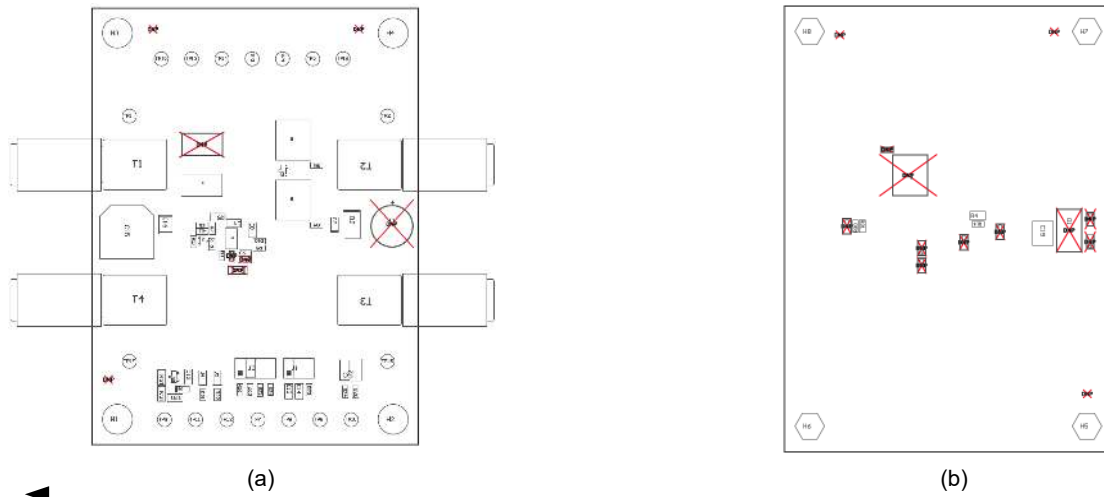

Figure 6-1. TPS48110Q1EVM Board (a) Top Assembly (b) Bottom Assembly

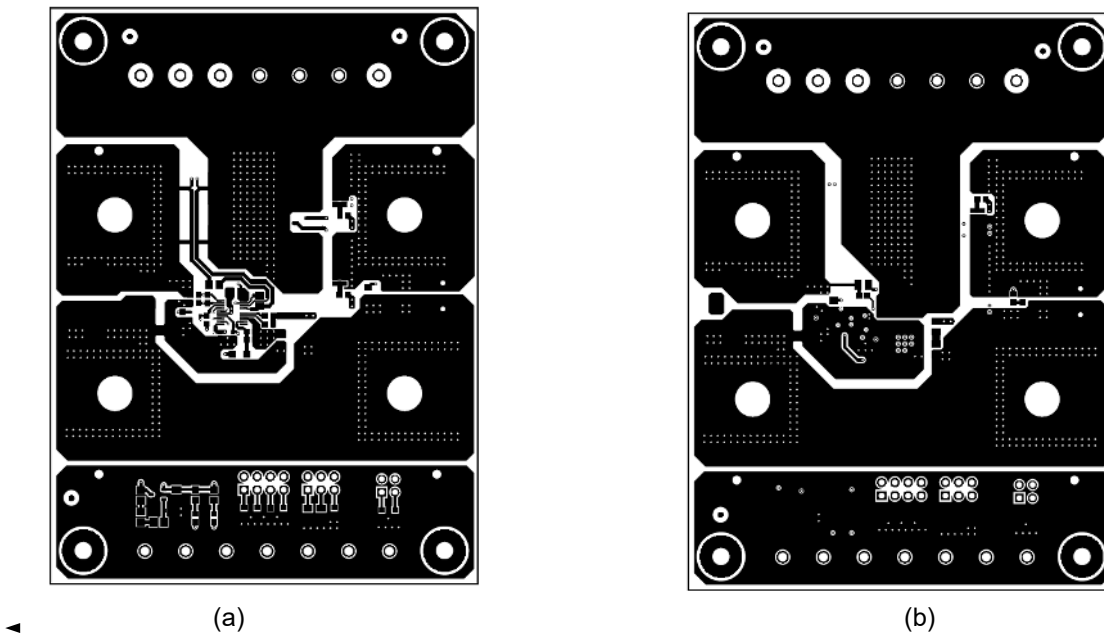

Figure 6-2. TPS48110Q1EVM Board (a) Top Layer (b) Bottom Layer

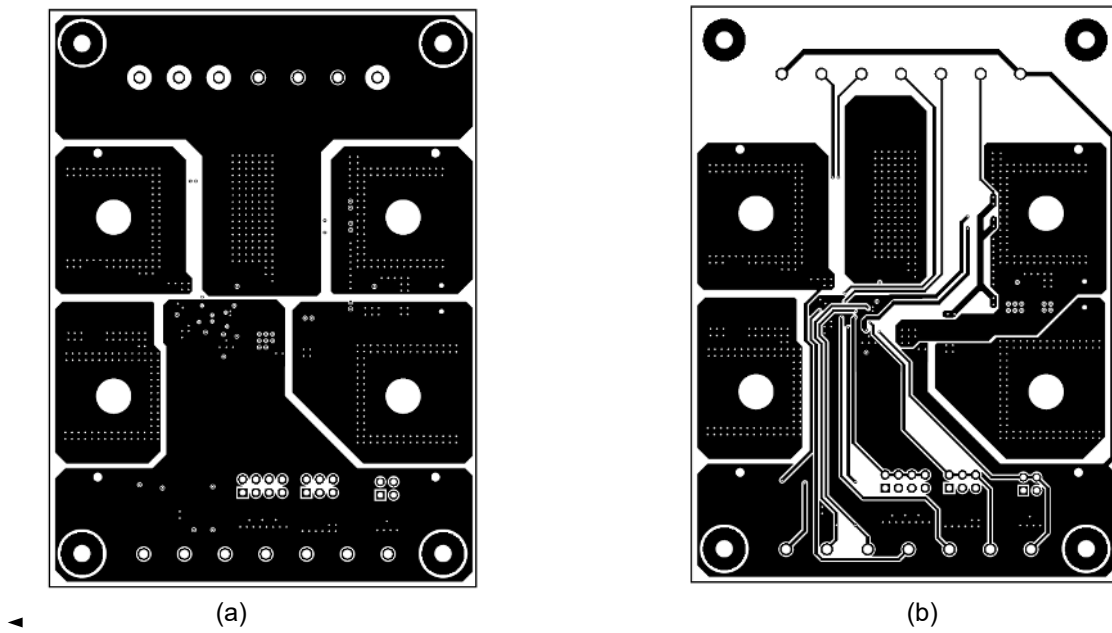

Figure 6-3. TPS48110Q1EVM Board (a) Inner Signal Layer (b) Inner Routing Layer

7 Bill of Materials (BoM)

Table 7-1 lists the EVM BoM.

Table 7-1. TPS48110Q1EVM Bill of Materials

Designator	Quantity	Value	Description	Package Reference	Part Number	Manufacturer
!PCB1	1		Printed Circuit Board		PSIL179	Any
C4	1	0.1 uF	CAP, CERM, 0.1 uF, 100 V, +/- 10%, X7R, AEC-Q200 Grade 1, 0805	0805	CGA4J2X7R2A104K125AA	TDK
C6	1	0.47 uF	CAP, CERM, 0.47 uF, 25 V, +/- 10%, X7R, AEC-Q200 Grade 1, 0603	0603	CGA3E3X7R1E474K080AB	TDK
C8	1	1000 pF	CAP, CERM, 1000 pF, 50 V, +/- 5%, X7R, 0805	0805	C0805C102J5RACTU	Kemet
C11	1	1000 pF	CAP, CERM, 1000 pF, 10 V, +/- 10%, X7R, 0402	0402	0402ZC102KAT2A	AVX
C12	1	2.2 uF	CAP, CERM, 2.2 uF, 25 V, +/- 10%, X7R, AEC-Q200 Grade 1, 0805	0805	GCM21BR71E225KA73L	MuRata
C13	1	0.068 uF	CAP, CERM, 0.068 uF, 100 V, +/- 10%, X7R, 0805	0805	C0805C683K1RACTU	Kemet
C14	1	0.68 uF	CAP, CERM, 0.68 uF, 50 V, +/- 10%, X7R, 0805	0805	C0805C684K5RACTU	Kemet
C15	1	47 uF	CAP, AL, 47 uF, 100 V, +/- 20%, 0.32 ohm, AEC-Q200 Grade 2, SMD	SMT Radial H13	EEV-FK2A470Q	Panasonic
C16	1	1 uF	CAP, CERM, 1 uF, 100 V, +/- 10%, X7R, 1812	1812	C4532X7R2A105K230KA	TDK
C19	1	10uF	CAP, CERM, 10 uF, 100 V, +/- 20%, X7R, 2220	2220	22201C106MAT2A	AVX
D2	1	100 V	Diode, Schottky, 100 V, 2 A, SMB	SMB	SS2H10-E3/5BT	Vishay-Semiconductor
D7	1	Green	LED, Green, SMD	LED_0805	LTST-C170KGKT	Lite-On
D4, D5	2	Red	LED, Red, SMD	Red 0805 LED	LTST-C170KRKT	Lite-On
D6	1	5.6 V	Diode, Zener, 5.6 V, 300 mW, AEC-Q101, SOD-323	SOD-323	SZMM3Z5V6ST1G	ON Semiconductor
H1, H2, H3, H4	4		Machine Screw, Round, #4-40 x 1/4, Nylon, Philips panhead	Screw	NY PMS 440 0025 PH	B&F Fastener Supply
H5, H6, H7, H8	4			Standoff	1902C	Keystone
J1	1		Header, 100mil, 3x2, Tin, TH	3x2 Header	PEC03DAAN	Sullins Connector Solutions
J2	1		Header, 100mil, 2x2, Tin, TH	Header, 2x2, 2.54mm, TH	PEC02DAAN	Sullins Connector Solutions

Table 7-1. TPS48110Q1EVM Bill of Materials (continued)

Designator	Quantity	Value	Description	Package Reference	Part Number	Manufacturer
J3	1		Header, 100mil, 4x2, Tin, TH	Header, 4x2, 100mil, Tin	PEC04DAAN	Sullins Connector Solutions
Q1, Q2	2		N-Channel 80V 300A (Tc) 375W (Tc) Surface Mount PG-HSOG-8-1	H SOG-8	IAUS300N08S5N012ATMA1	Infineon
Q4	1	60 V	MOSFET, N-CH, 60 V, 0.115 A, SOT-323	SOT-323	2N7002W-7-F	Diodes Inc.
Q5	1	160 V	Transistor, NPN, 160 V, 0.3 A, SOT-23	SOT-23	PMBT5551,215	Nexperia
Q6	1	40 V	Transistor, NPN, 40 V, 0.2 A, SOT-23	SOT-23	MMBT3904	Fairchild Semiconductor
R1	1	500 μ	Res Metal Strip 3921 0.0005 Ohm 1% 3W \pm 175ppm/ $^{\circ}$ C Molded SMD SMD Embossed Plastic T/R	3921	WSL3921L5000FEA	Vishay Dale
R3	1	470k	RES, 470 k, 1%, 0.1 W, 0603	0603	RC0603FR-07470KL	Yageo
R4, R5	2	100	RES, 100, 1%, 0.125 W, AEC-Q200 Grade 0, 0805	0805	CRCW0805100RFKEA	Vishay-Dale
R6, R8	2	2.21	RES, 2.21, 1%, 0.1 W, 0603	0603	RC0603FR-072R21L	Yageo
R7	1	14.3k	RES, 14.3 k, 1%, 0.1 W, 0603	0603	RC0603FR-0714K3L	Yageo
R9	1	0	RES, 0, 5%, 0.1 W, AEC-Q200 Grade 0, 0603	0603	CRCW06030000Z0EA	Vishay-Dale
R10	1	10.0	RES, 10.0, 1%, 0.25 W, AEC-Q200 Grade 0, 0603	0603	CRCW060310R0FKEAHP	Vishay-Dale
R11	1	10.2k	RES, 10.2 k, 1%, 0.1 W, 0603	0603	RC0603FR-0710K2L	Yageo
R17, R30, R31	3	9.53 k	RES, 9.53 k, 1%, 0.1 W, 0603	0603	RC0603FR-079K53L	Yageo
R12, R21, R22	3	3.16 k	RES, 3.16 k, 1%, 0.1 W, AEC-Q200 Grade 0, 0603	0603	CRCW06033K16FKEA	Vishay-Dale
R14	1	1.47 k	RES, 1.47 k, 0.1%, 0.1 W, 0603	0603	RT0603BRD071K47L	Yageo America
R18, R19, R20	3	10.0 k	RES, 10.0 k, 1%, 0.125 W, AEC-Q200 Grade 0, 0805	0805	ERJ-6ENF1002V	Panasonic
R23	1	100 k	RES, 100 k, 1%, 0.1 W, AEC-Q200 Grade 0, 0603	0603	CRCW0603100KFKEA	Vishay-Dale
R24	1	41.2 k	RES, 41.2 k, 1%, 0.1 W, 0603	0603	RC0603FR-0741K2L	Yageo
R25	1	20.0 k	RES, 20.0 k, 0.5%, 0.1 W, 0603	0603	RT0603DRE0720KL	Yageo America
R26	1	0	RES, 0, 5%, 0.1 W, 0603	0603	ERJ-3GEY0R00V	Panasonic
R27	1	475 k	RES, 475 k, 1%, 0.1 W, 0603	0603	RC0603FR-07475KL	Yageo

Table 7-1. TPS48110Q1EVM Bill of Materials (continued)

Designator	Quantity	Value	Description	Package Reference	Part Number	Manufacturer
R28	1	158 k	RES, 158 k, 1%, 0.1 W, AEC-Q200 Grade 0, 0603	0603	CRCW0603158KFKEA	Vishay-Dale
R29	1	47.0 k	RES, 47.0 k, 1%, 0.1 W, AEC-Q200 Grade 0, 0603	0603	CRCW060347K0FKEA	Vishay-Dale
SH-J1, SH-J2, SH-J3	3	1x2	Shunt, 100mil, Flash Gold, Black	Closed Top 100mil Shunt	SPC02SYAN	Sullins Connector Solutions
T1, T2, T3, T4	4		Terminal 90A Lug	CB70-14-CY	CB70-14-CY	Panduit
TP1, TP2, TP9	3		Test Point, Multipurpose, Red, TH	Red Multipurpose Testpoint	5010	Keystone
TP3, TP4, TP5, TP6, TP8, TP10, TP11, TP12, TP13, TP14	10		Test Point, Multipurpose, White, TH	White Multipurpose Testpoint	5012	Keystone
TP7	1		Test Point, Multipurpose, Orange, TH	Orange Multipurpose Testpoint	5013	Keystone
TP15, TP16, TP17, TP18	4		Test Point, Multipurpose, Black, TH	Black Multipurpose Testpoint	5011	Keystone
U1	1		100V Smart High Side controller with Protection and Diagnostics	VSSOP20	PTPS48110-Q1	Texas Instruments
C1	0	0.01 uF	CAP, CERM, 0.01 uF, 100 V, +/- 10%, X7R, 1206	1206	12061C103KAT2A	AVX
C2	0	47uF	CAP, AL, 47 uF, 100 V, +/- 20%, 0.43 ohm, TH	10x12.5mm	UHE2A470MPD	Nichicon
C3, C5, C9	0	0.1 uF	CAP, CERM, 0.1 uF, 100 V, +/- 10%, X7R, AEC-Q200 Grade 1, 0805	0805	CGA4J2X7R2A104K125AA	TDK
C7	0	0.47 uF	CAP, CERM, 0.47 uF, 25 V, +/- 10%, X7R, AEC-Q200 Grade 1, 0603	0603	CGA3E3X7R1E474K080AB	TDK
C10	0	330 pF	CAP, CERM, 330 pF, 50 V, +/- 10%, X7R, 0402	0402	GRM155R71H331KA01D	MuRata
C18	0	0.01 uF	CAP, CERM, 0.01 uF, 100 V, +/- 5%, X7R, 0805	0805	08051C103JAT2A	AVX
D1	0	70 V	Diode, TVS, Uni, 70 V, 113 Vc, SMC	SMC	SMCJ70A	Littelfuse
D3	0	100 V	Diode, Schottky, 100 V, 0.25 A, SOD-123F	SOD-123F	BAT46WH,115	Nexperia
FID1, FID2, FID3, FID4, FID5, FID6	0		Fiducial mark. There is nothing to buy or mount.	N/A	N/A	N/A

Table 7-1. TPS48110Q1EVM Bill of Materials (continued)

Designator	Quantity	Value	Description	Package Reference	Part Number	Manufacturer
Q3	0		N-Channel 80V 300A (Tc) 375W (Tc) Surface Mount PG-HSOG-8-1	H SOG-8	IAUS300N08S5N012ATMA1	Infineon
R2	0	500 μ	Res Metal Strip 3921 0.0005 Ohm 1% 3W \pm 175ppm/ $^{\circ}$ C Molded SMD SMD Embossed Plastic T/R	3921	WSL3921L5000FEA	Vishay Dale
R16	0	100	RES, 100, 1%, 0.5 W, AEC-Q200 Grade 0, 1206	1206	CRCW1206100RFKEAHP	Vishay-Dale
R13	0	0	RES, 0, 5%, 0.1 W, AEC-Q200 Grade 0, 0603	0603	CRCW06030000Z0EA	Vishay-Dale
R15	0	10.0	RES, 10.0, 1%, 0.125 W, 0805	0805	RC0805FR-0710RL	Yageo America

8 Revision History

NOTE: Page numbers for previous revisions may differ from page numbers in the current version.

Changes from Revision * (May 2022) to Revision A (December 2022)	Page
• Updated TPS48110Q1EVM Evaluation Module Schematic.....	3
• Updated TPS48110Q1EVM Setup with Test Equipment.....	5

IMPORTANT NOTICE AND DISCLAIMER

TI PROVIDES TECHNICAL AND RELIABILITY DATA (INCLUDING DATA SHEETS), DESIGN RESOURCES (INCLUDING REFERENCE DESIGNS), APPLICATION OR OTHER DESIGN ADVICE, WEB TOOLS, SAFETY INFORMATION, AND OTHER RESOURCES "AS IS" AND WITH ALL FAULTS, AND DISCLAIMS ALL WARRANTIES, EXPRESS AND IMPLIED, INCLUDING WITHOUT LIMITATION ANY IMPLIED WARRANTIES OF MERCHANTABILITY, FITNESS FOR A PARTICULAR PURPOSE OR NON-INFRINGEMENT OF THIRD PARTY INTELLECTUAL PROPERTY RIGHTS.

These resources are intended for skilled developers designing with TI products. You are solely responsible for (1) selecting the appropriate TI products for your application, (2) designing, validating and testing your application, and (3) ensuring your application meets applicable standards, and any other safety, security, regulatory or other requirements.

These resources are subject to change without notice. TI grants you permission to use these resources only for development of an application that uses the TI products described in the resource. Other reproduction and display of these resources is prohibited. No license is granted to any other TI intellectual property right or to any third party intellectual property right. TI disclaims responsibility for, and you will fully indemnify TI and its representatives against, any claims, damages, costs, losses, and liabilities arising out of your use of these resources.

TI's products are provided subject to [TI's Terms of Sale](#) or other applicable terms available either on ti.com or provided in conjunction with such TI products. TI's provision of these resources does not expand or otherwise alter TI's applicable warranties or warranty disclaimers for TI products.

TI objects to and rejects any additional or different terms you may have proposed.

Mailing Address: Texas Instruments, Post Office Box 655303, Dallas, Texas 75265
Copyright © 2022, Texas Instruments Incorporated