

FEATURES

- Fits Hittite Microwave VCOs with LP4E packages
- Usable with HMC384-386, 388-391, 416, 429-431, 466, 505, 506, 532 VCOs
- VCOs frequencies from 2-8 GHz
- Uses standard SMD passive parts
- RO-4350 board material
- Fits MicroAmp MH-series housings

The MicroAmp MB-13 circuit board is designed for rapid prototyping of microwave VCOs using Hittite Microwave devices in LP4E packages with RF outputs on pin 16, tuning controls on pin 22, and bias on pin 20. This board will fit the MicroAmp MH series of connectorized housings that allow it to be used as a stand-alone oscillator or cascaded with other MicroAmp boards for added versatility. Boards are fabricated from a high-performance 13 mil thick RO-4350 laminate with RoHS compatible ENIG plating (electroless nickel/immersion gold) on both the component side and the solid bottom ground plane. The board measures 0.490" x 0.590" and mounts into the housing with four or six #1-72 screws for optimal high frequency grounding. Oscillator circuits can be easily designed and assembled with standard surface-mount passive components. It includes provisions for DC bias bypassing and configuring the tuning pin to be connected to either an SMA input connector or feed-through in the housing. Pads for the input/output connectors allow the SMA center pins to be easily soldered to the board after it is installed into the housing, as well as large pads to connect the bias voltage and tuning input pins. The tuning pin has the option of connecting to the J1 SMA connector or to a feed-through by preferential installation of R1.

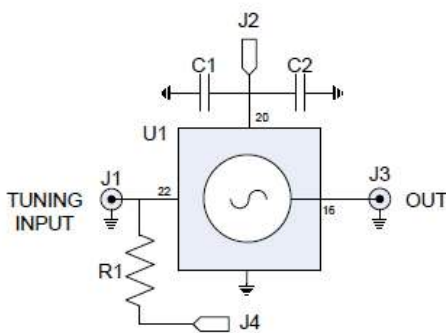

VOG SCHEMATIC

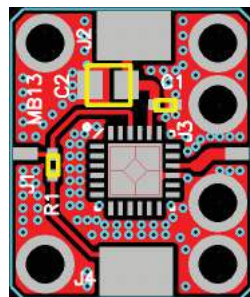

ASSEMBLY

REF	SIZE	FUNCTION
C1	0402	Bias bypass
C2	0805	Bias bypass
R1	0402	Tuning pin connection
U1	LP4E	VCO
J1		Coax tuning input (pin 22)
J2		+ Bias (pin 20)
J3		RF output (pin 16)
J4		R1 tuning input (pin 22)

For additional product information, please visit www.twinind.com

Contact information: 925-866-8946 (phone) 925-866-8937 (fax) Sales@twinind.com