

General Description

The ICS874001I-05 is a high performance Jitter Attenuator designed for use in PCI Express™ systems. In some PCI Express systems, such as those found in desktop PCs, the PCI Express clocks are generated from a low bandwidth, high phase noise PLL frequency synthesizer. In these systems, a jitter attenuator may be required to attenuate high frequency random and deterministic jitter components from the PLL synthesizer and from the system board. The ICS874001I-05 has a bandwidth of 6MHz with <1dB peaking, easily meeting PCI Express Gen2 PLL requirements.

The ICS874001I-05 uses IDT's 3RD Generation FemtoClock® PLL technology to achieve the lowest possible phase noise. The device is packaged in a small 20-pin TSSOP package, making it ideal for use in space constrained applications such as PCI Express add-in cards.

Features

- One differential LVDS output pair
- One differential clock input
- CLK, nCLK supports the following input levels: LVPECL, LVDS, LVHSTL, SSTL, HCSL
- Input frequency range: 98MHz to 128MHz
- Output frequency range: 98MHz to 640MHz
- VCO range: 490MHz - 640MHz
- Cycle-to-cycle jitter: 50ps (maximum)
- Full 3.3V operating supply
- PCI Express (2.5Gb/s) and Gen 2 (5 Gb/s) jitter compliant
- -40°C to 85°C ambient operating temperature
- Available in lead-free (RoHS 6) package

Pin Assignment

| | | | |
|---------|----|----|------|
| PLL_SEL | 1 | 20 | nc |
| nc | 2 | 19 | VDD0 |
| nc | 3 | 18 | Q |
| nc | 4 | 17 | nQ |
| MR | 5 | 16 | nc |
| nc | 6 | 15 | nc |
| F_SEL1 | 7 | 14 | GND |
| VDDA | 8 | 13 | nCLK |
| F_SEL0 | 9 | 12 | CLK |
| VDD | 10 | 11 | OE |

ICS874001I-05
20-Lead TSSOP
6.5mm x 4.4mm x 0.925mm
package body
G Package
Top View

Block Diagram

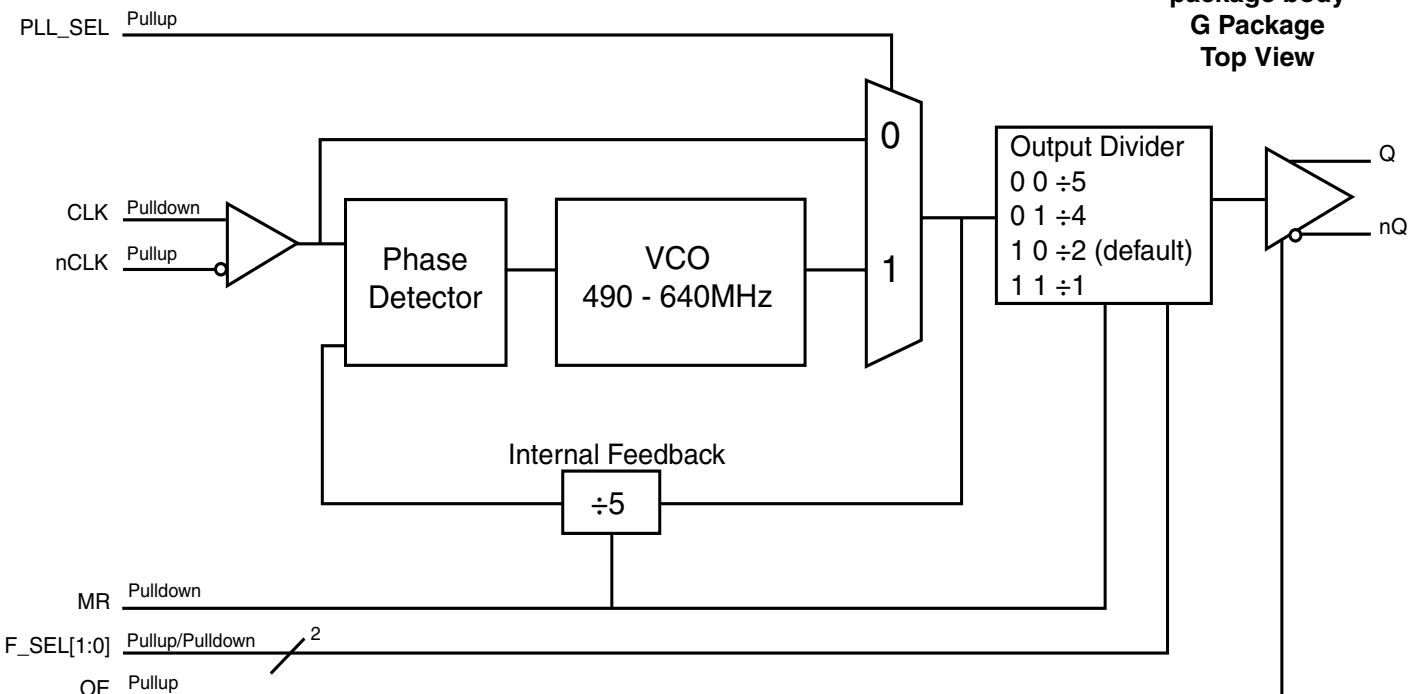

Table 1. Pin Descriptions

| Number | Name | Type | | Description |
|------------------------|------------------|--------|----------|---|
| 1 | PLL_SEL | Input | Pullup | PLL select pin. When LOW, bypasses the PLL. When HIGH selects the PLL. LVCMOS/LVTTL interface levels. See Table 3B. |
| 2, 3, 4, 6, 15, 16, 20 | nc | Unused | | No connect. |
| 5 | MR | Input | Pulldown | Active High Master Reset. When logic HIGH, the internal dividers are reset causing the true output Q to go LOW and the inverted output nQ to go HIGH. When logic LOW, the internal dividers and the outputs are enabled. LVCMOS/LVTTL interface levels. |
| 7 | F_SEL1 | Input | Pullup | Frequency select pin. LVCMOS/LVTTL interface levels. See Table 3C. |
| 8 | V _{DDA} | Power | | Analog supply pin. |
| 9 | F_SEL0 | Input | Pulldown | Frequency select pin. LVCMOS/LVTTL interface levels. See Table 3C. |
| 10 | V _{DD} | Power | | Core supply pin. |
| 11 | OE | Input | Pullup | Output enable. When HIGH, outputs are enabled. When LOW, forces outputs to a High-Impedance state. LVCMOS/LVTTL interface levels. See Table 3A. |
| 12 | CLK | Input | Pulldown | Non-inverting differential clock input. |
| 13 | nCLK | Input | Pullup | Inverting differential clock input. |
| 14 | GND | Power | | Power supply ground. |
| 17, 18 | nQ, Q | Output | | Differential output pair. LVDS interface levels. |
| 19 | V _{DDO} | Power | | Output supply pin. |

NOTE: *Pullup and Pulldown* refer to internal input resistors. See Table 2, *Pin Characteristics*, for typical values.

Table 2. Pin Characteristics

| Symbol | Parameter | Test Conditions | Minimum | Typical | Maximum | Units |
|-----------------------|-------------------------|-----------------|---------|---------|---------|-------|
| C _{IN} | Input Capacitance | | | 4 | | pF |
| R _{PULLUP} | Input Pullup Resistor | | | 51 | | kΩ |
| R _{PULLDOWN} | Input Pulldown Resistor | | | 51 | | kΩ |

Function Tables

Table 3A. Output Enable Function Table

| Inputs | Outputs |
|-------------|----------------|
| OE | Q, nQ |
| 0 | High-Impedance |
| 1 (default) | Enabled |

Table 3B. PLL_SEL Control Table

| Inputs | Function |
|---------|---------------|
| PLL_SEL | |
| 0 | Bypass |
| 1 | VCO (default) |

Table 3C. F_SELx Function Table

| Inputs | | | Output Frequency (MHz) |
|--------|--------|----------------|------------------------|
| F_SEL1 | F_SEL0 | Output Divider | |
| 0 | 0 | ÷5 | 98 - 128 |
| 0 | 1 | ÷4 | 122.5 - 160 |
| 1 | 0 | ÷2 | 245 - 320 (default) |
| 1 | 1 | ÷1 | 490 - 640 |

Absolute Maximum Ratings

NOTE: Stresses beyond those listed under *Absolute Maximum Ratings* may cause permanent damage to the device. These ratings are stress specifications only. Functional operation of product at these conditions or any conditions beyond those listed in the *DC Characteristics* or *AC Characteristics* is not implied. Exposure to absolute maximum rating conditions for extended periods may affect product reliability.

| Item | Rating |
|---|--------------------------|
| Supply Voltage, V_{DD} | 4.6V |
| Inputs, V_I | -0.5V to $V_{DD} + 0.5V$ |
| Outputs, I_O Continuous Current Surge Current | 10mA 15mA |
| Package Thermal Impedance, θ_{JA} | 86.7°C/W (0 mps) |
| Storage Temperature, T_{STG} | -65°C to 150°C |

DC Electrical Characteristics

Table 4A. Power Supply DC Characteristics, $V_{DD} = V_{DDO} = 3.3V \pm 0.3V$, $T_A = -40^\circ C$ to $85^\circ C$

| Symbol | Parameter | Test Conditions | Minimum | Typical | Maximum | Units |
|-----------|-----------------------|-----------------|-----------------|---------|----------|-------|
| V_{DD} | Core Supply Voltage | | 3.0 | 3.3 | 3.6 | V |
| V_{DDA} | Analog Supply Voltage | | $V_{DD} - 0.13$ | 3.3 | V_{DD} | V |
| V_{DDO} | Output Supply Voltage | | 3.0 | 3.3 | 3.6 | V |
| I_{DD} | Power Supply Current | | | | 75 | mA |
| I_{DDA} | Analog Supply Current | | | | 13 | mA |
| I_{DDO} | Output Supply Current | | | | 25 | mA |

Table 4B. LVCMOS/LVTTL DC Characteristics, $V_{DD} = V_{DDO} = 3.3V \pm 0.3V$, $T_A = -40^\circ C$ to $85^\circ C$

| Symbol | Parameter | Test Conditions | Minimum | Typical | Maximum | Units |
|----------|--------------------|---------------------|------------------------------|---------|----------------|---------|
| V_{IH} | Input High Voltage | | 2 | | $V_{DD} + 0.3$ | V |
| V_{IL} | Input Low Voltage | | -0.3 | | 0.8 | V |
| I_{IH} | Input High Current | PLL_SEL, F_SEL1, OE | $V_{DD} = V_{IN} = 3.6V$ | | 5 | μA |
| | | F_SELO, MR | $V_{DD} = V_{IN} = 3.6V$ | | 150 | μA |
| I_{IL} | Input Low Current | PLL_SEL, F_SEL1, OE | $V_{DD} = 3.6V, V_{IN} = 0V$ | -150 | | μA |
| | | F_SELO, MR | $V_{DD} = 3.6V, V_{IN} = 0V$ | -5 | | μA |

Table 4C. Differential DC Characteristics, $V_{DD} = V_{DDO} = 3.3V \pm 0.3V$, $T_A = -40^{\circ}C$ to $85^{\circ}C$

| Symbol | Parameter | Test Conditions | Minimum | Typical | Maximum | Units |
|-----------|--------------------------------------|-----------------|------------------------------|---------|-----------------|---------|
| I_{IH} | Input High Current | CLK | $V_{DD} = V_{IN} = 3.6V$ | | 150 | μA |
| | | nCLK | $V_{DD} = V_{IN} = 3.6V$ | | 5 | μA |
| I_{IL} | Input Low Current | CLK | $V_{DD} = 3.6V, V_{IN} = 0V$ | -5 | | μA |
| | | nCLK | $V_{DD} = 3.6V, V_{IN} = 0V$ | -150 | | μA |
| V_{PP} | Peak-to-Peak Voltage; NOTE 1 | | 0.15 | | 1.3 | V |
| V_{CMR} | Common Mode Input Voltage; NOTE 1, 2 | | GND + 0.5 | | $V_{DD} - 0.85$ | V |

NOTE 1: V_{IL} should not be less than -0.3V.

NOTE 2: Common mode input voltage is defined as V_{IH} .

Table 4D. LVDS DC Characteristics, $V_{DD} = V_{DDO} = 3.3V \pm 0.3V$, $T_A = -40^{\circ}C$ to $85^{\circ}C$

| Symbol | Parameter | Test Conditions | Minimum | Typical | Maximum | Units |
|-----------------|-----------------------------|-----------------|---------|---------|---------|-------|
| V_{OD} | Differential Output Voltage | | 275 | 375 | 485 | mV |
| ΔV_{OD} | V_{OD} Magnitude Change | | | | 50 | mV |
| V_{OS} | Offset Voltage | | 1.20 | 1.35 | 1.50 | V |
| ΔV_{OS} | V_{OS} Magnitude Change | | | | 50 | mV |

AC Electrical Characteristics

Table 5. AC Characteristics, $V_{DD} = V_{DDO} = 3.3V \pm 0.3V$, $T_A = -40^\circ C$ to $85^\circ C$

| Symbol | Parameter | Test Conditions | Minimum | Typical | Maximum | Units |
|---------------------------------------|---|---|---------|---------|---------|-------|
| f_{OUT} | Output Frequency | | 98 | | 640 | MHz |
| $f_{jit(cc)}$ | Cycle-to-Cycle Jitter; NOTE 1 | | | | 50 | ps |
| T_j (PCIe Gen 1) | Phase Jitter Peak-to-Peak; NOTE 2, 4 | 100MHz output, Evaluation Band: 0Hz - Nyquist (clock frequency/2) | | 16.14 | | ps |
| | | 125MHz output, Evaluation Band: 0Hz - Nyquist (clock frequency/2) | | 15.64 | | ps |
| | | 250MHz output, Evaluation Band: 0Hz - Nyquist (clock frequency/2) | | 13.16 | | ps |
| | | 500MHz, (1.2MHz –21.9MHz), Evaluation Band: 0Hz - Nyquist (clock frequency/2) | | 12.17 | | ps |
| $T_{REFCLK_HF_RMS}$ (PCIe Gen 2) | Phase Jitter RMS; NOTE 3, 4 | 100MHz output, High Band: 1.5MHz - Nyquist (clock frequency/2) | | 1.4 | | ps |
| | | 125MHz output, High Band: 1.5MHz - Nyquist (clock frequency/2) | | 1.39 | | ps |
| | | 250MHz output, High Band: 1.5MHz - Nyquist (clock frequency/2) | | 1.18 | | ps |
| | | 500MHz output, High Band: 1.5MHz - Nyquist (clock frequency/2) | | 1.11 | | ps |
| $T_{REFCLK_LF_RMS}$ (PCIe Gen 2) | Phase Jitter RMS; NOTE 3, 4 | 100MHz output, Low Band: 10kHz - 1.5MHz | | 0.33 | | ps |
| | | 125MHz output, Low Band: 10kHz - 1.5MHz | | 0.22 | | ps |
| | | 250MHz output, Low Band: 10kHz - 1.5MHz | | 0.22 | | ps |
| | | 500MHz output, Low Band: 10kHz - 1.5MHz | | 0.22 | | ps |
| t_R / t_F | Output Rise/Fall Time | 20% to 80% | 200 | | 600 | ps |
| odc | Output Duty Cycle | $F_SEL[10] \neq 11$ | 48 | | 52 | % |
| | | $F_SEL[10] = 11$ | 42 | | 58 | % |

NOTE: Electrical parameters are guaranteed over the specified ambient operating temperature range, which is established when the device is mounted in a test socket with maintained transverse airflow greater than 500 lpm. The device will meet specifications after thermal equilibrium has been reached under these conditions.

NOTE 1: This parameter is defined in accordance with JEDEC Standard 65.

NOTE 2: Peak-to-Peak jitter after applying system transfer function for the Common Clock Architecture. Maximum limit for PCI Express Gen 1 is 86ps peak-to-peak for a sample size of 10^6 clock periods.

NOTE 3: RMS jitter after applying the two evaluation bands to the two transfer functions defined in the Common Clock Architecture and reporting the worst case results for each evaluation band. Maximum limit for PCI Express Generation 2 is 3.1ps RMS for $t_{REFCLK_HF_RMS}$ (High Band) and 3.0ps RMS for $t_{REFCLK_LF_RMS}$ (Low Band).

NOTE 4: Guaranteed only when input clock source is PCI Express and PCI Express Gen 2 compliant.

Parameter Measurement Information

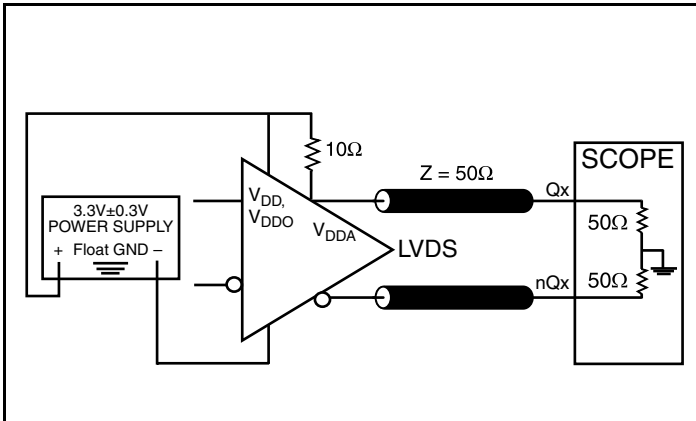

3.3V LVDS Output Load AC Test Circuit

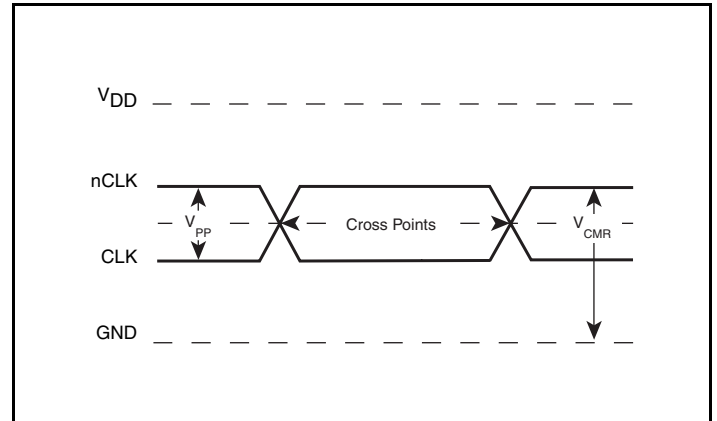

Differential Input Level

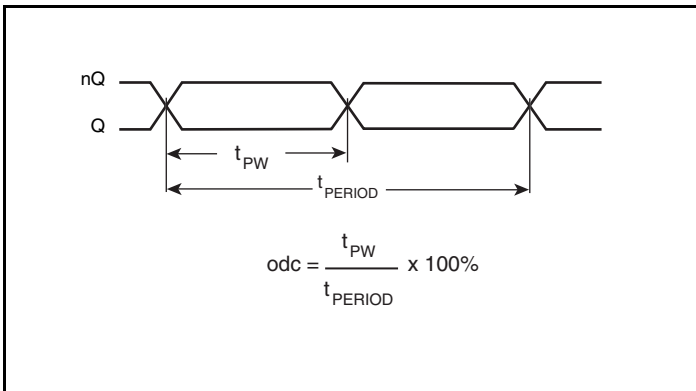

Output Duty Cycle/Pulse Width/Period

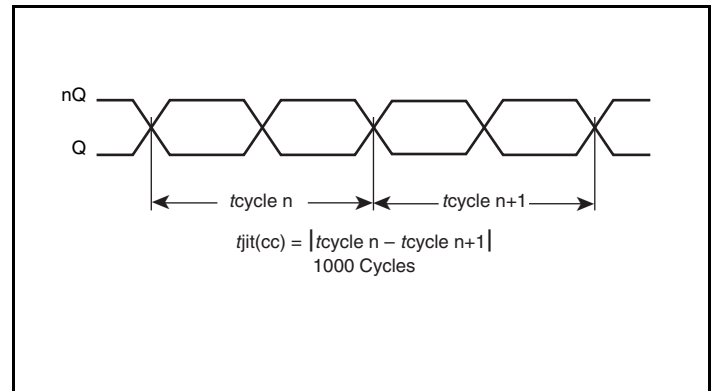

Cycle-to-Cycle Jitter

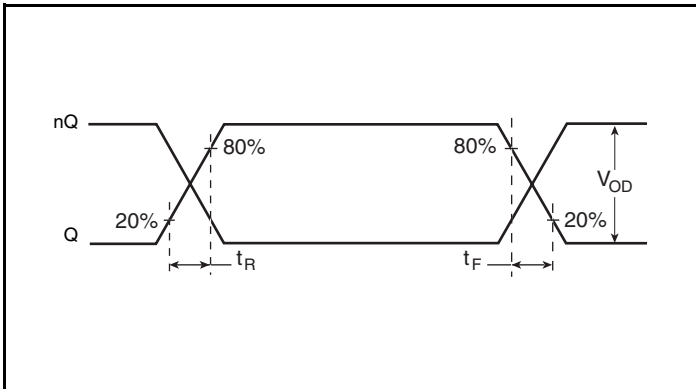

Output Rise/Fall Time

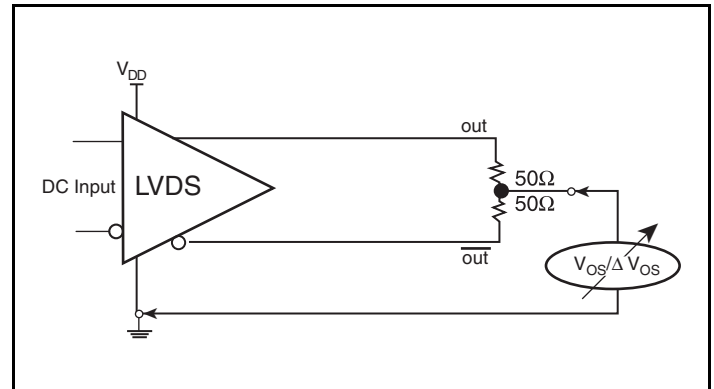

Offset Voltage Setup

Parameter Measurement Information, continued

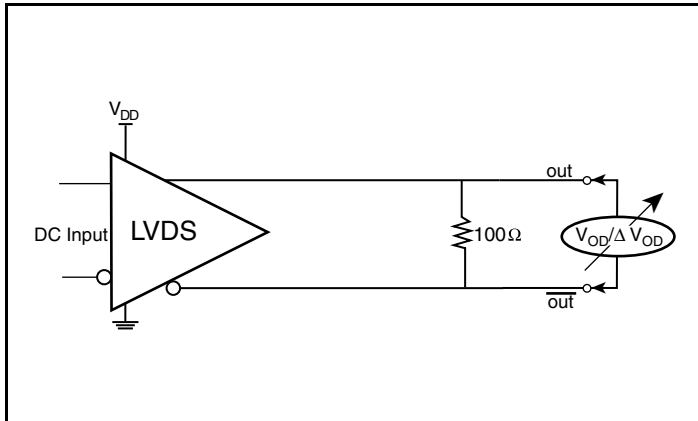

Differential Output Voltage Setup

Applications Information

Recommendations for Unused Input Pins

Inputs:

LVC MOS Control Pins

All control pins have internal pull-ups or pull-downs; additional resistance is not required but can be added for additional protection. A 1kΩ resistor can be used.

Wiring the Differential Input to Accept Single-Ended Levels

Figure 1 shows how a differential input can be wired to accept single ended levels. The reference voltage $V_{REF} = V_{DD}/2$ is generated by the bias resistors R1 and R2. The bypass capacitor (C1) is used to help filter noise on the DC bias. This bias circuit should be located as close to the input pin as possible. The ratio of R1 and R2 might need to be adjusted to position the V_{REF} in the center of the input voltage swing. For example, if the input clock swing is 2.5V and $V_{DD} = 3.3V$, R1 and R2 value should be adjusted to set V_{REF} at 1.25V. The values below are for when both the single ended swing and V_{DD} are at the same voltage. This configuration requires that the sum of the output impedance of the driver (R_o) and the series resistance (R_s) equals the transmission line impedance. In addition, matched termination at the input will attenuate the signal in half. This can be done in one of two ways. First, R3 and R4 in parallel should equal the transmission

line impedance. For most 50Ω applications, R3 and R4 can be 100Ω . The values of the resistors can be increased to reduce the loading for slower and weaker LVCMOS driver. When using single-ended signaling, the noise rejection benefits of differential signaling are reduced. Even though the differential input can handle full rail LVCMOS signaling, it is recommended that the amplitude be reduced. The datasheet specifies a lower differential amplitude, however this only applies to differential signals. For single-ended applications, the swing can be larger, however V_{IL} cannot be less than $-0.3V$ and V_{IH} cannot be more than $V_{DD} + 0.3V$. Though some of the recommended components might not be used, the pads should be placed in the layout. They can be utilized for debugging purposes. The datasheet specifications are characterized and guaranteed by using a differential signal.

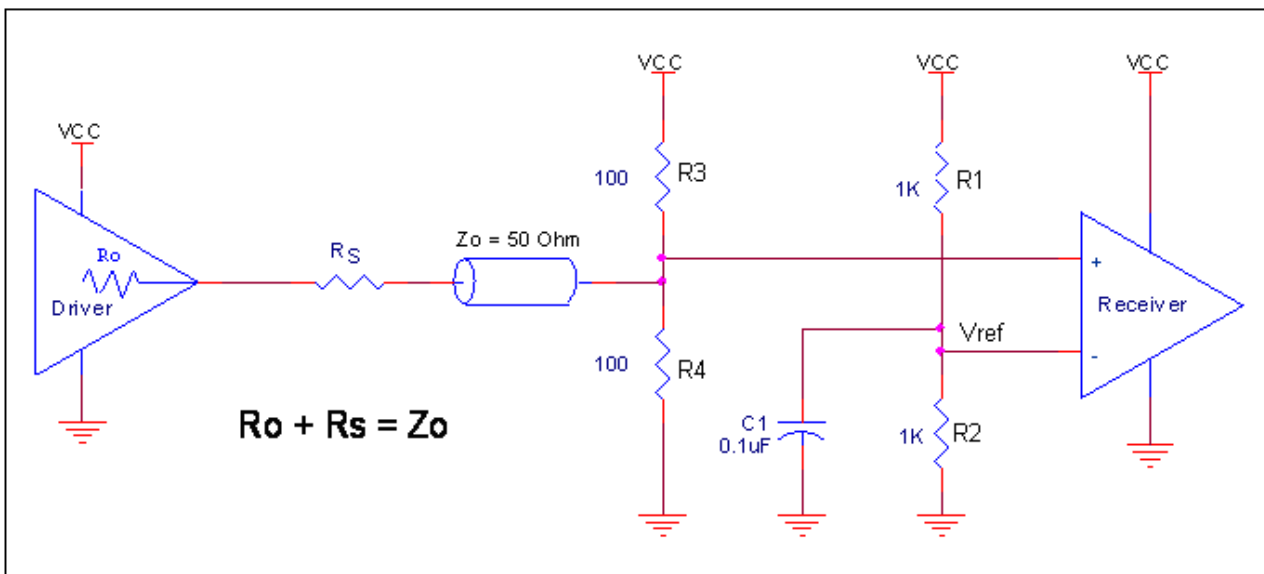
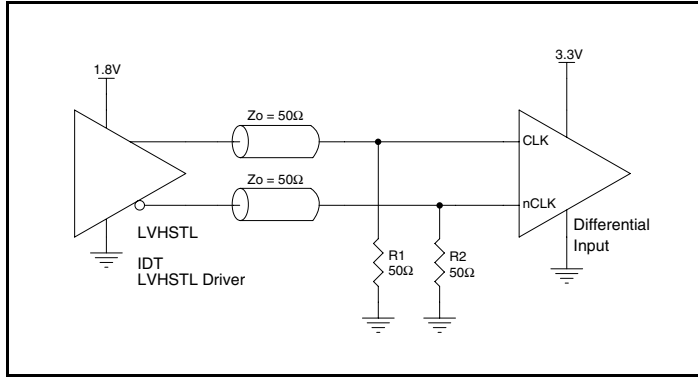

Figure 1. Recommended Schematic for Wiring a Differential Input to Accept Single-ended Levels

Differential Clock Input Interface

The CLK /nCLK accepts LVDS, LVPECL, LVHSTL, SSTL, HCSL and other differential signals. Both signals must meet the V_{PP} and V_{CMR} input requirements. *Figures 2A to 2F* show interface examples for the CLK/nCLK input driven by the most common driver types. The input interfaces suggested here are examples only. Please consult with the

vendor of the driver component to confirm the driver termination requirements. For example, in Figure 2A, the input termination applies for IDT open emitter LVHSTL drivers. If you are using an LVHSTL driver from another vendor, use their termination recommendation.



2A. CLK/nCLK Input Driven by an IDT Open Emitter LVHSTL Driver

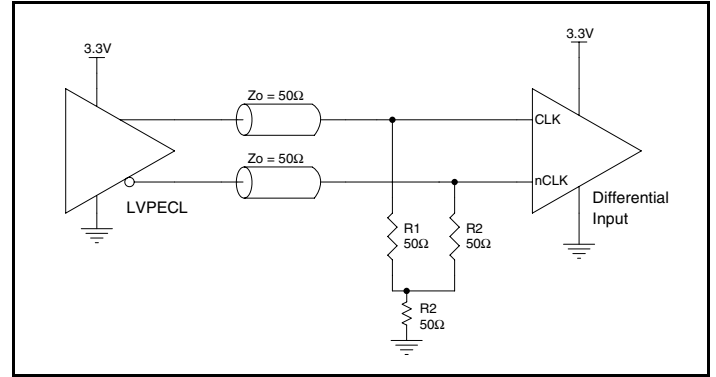

Figure 2B. CLK/nCLK Input Driven by a 3.3V LVPECL Driver

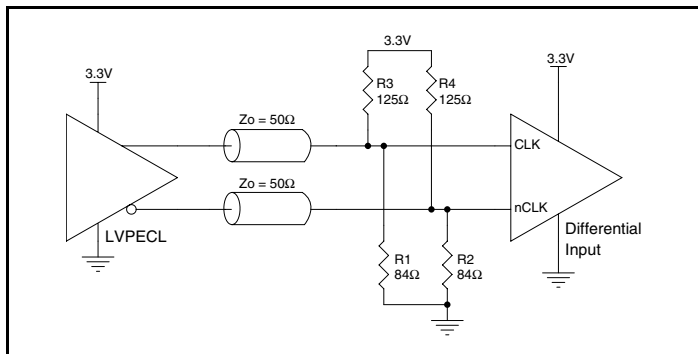

Figure 2C. CLK/nCLK Input Driven by a 3.3V LVPECL Driver

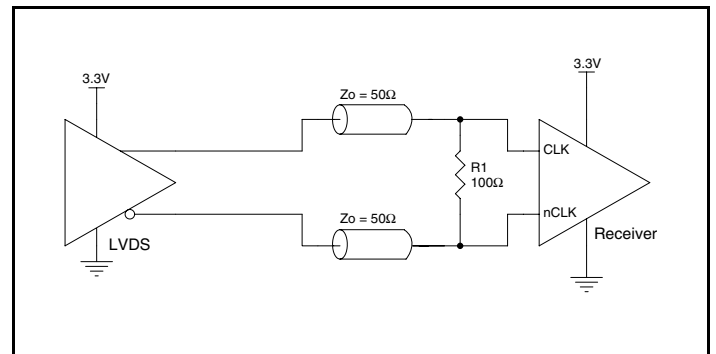

Figure 2D. CLK/nCLK Input Driven by a 3.3V LVDS Driver

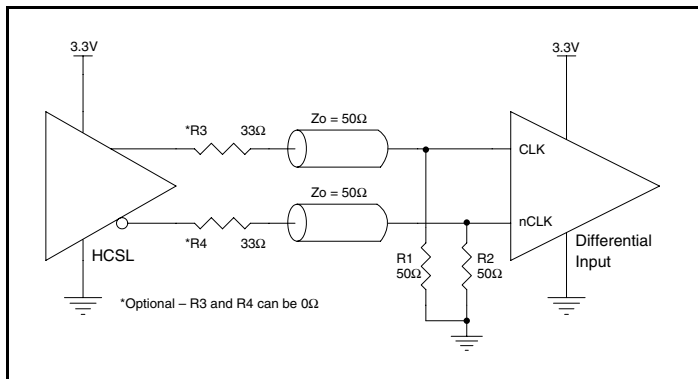

Figure 2E. CLK/nCLK Input Driven by a 3.3V HCSL Driver

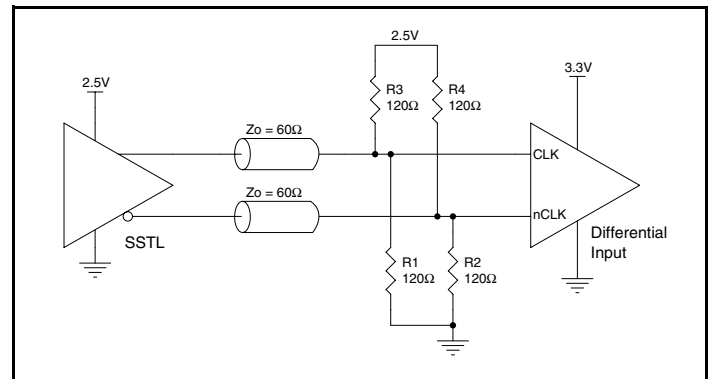

Figure 2F. CLK/nCLK Input Driven by a 2.5V SSTL Driver

LVDS Driver Termination

A general LVDS interface is shown in *Figure 3*. Standard termination for LVDS type output structure requires both a 100Ω parallel resistor at the receiver and a 100Ω differential transmission line environment. In order to avoid any transmission line reflection issues, the 100Ω resistor must be placed as close to the receiver as possible. IDT offers a full line of LVDS compliant devices with two types of output structures: current source and voltage source. The standard

termination schematic as shown in Figure 3 can be used with either type of output structure. If using a non-standard termination, it is recommended to contact IDT and confirm if the output is a current source or a voltage source type structure. In addition, since these outputs are LVDS compatible, the amplitude and common mode input range of the input receivers should be verified for compatibility with the output.

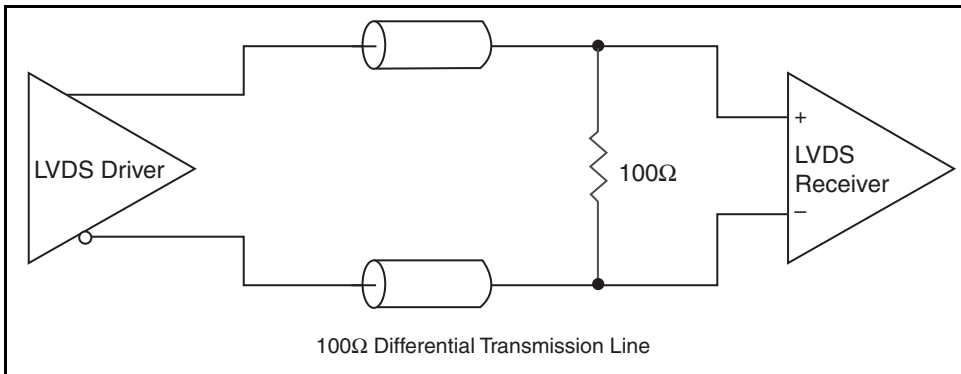

Figure 3. Typical LVDS Driver Termination

PCI Express Application Note

PCI Express jitter analysis methodology models the system response to reference clock jitter. The block diagram below shows the most frequently used *Common Clock Architecture* in which a copy of the reference clock is provided to both ends of the PCI Express Link.

In the jitter analysis, the transmit (Tx) and receive (Rx) serdes PLLs are modeled as well as the phase interpolator in the receiver. These transfer functions are called H1, H2, and H3 respectively. The overall system transfer function at the receiver is:

$$H_t(s) = H_3(s) \times [H_1(s) - H_2(s)]$$

The jitter spectrum seen by the receiver is the result of applying this system transfer function to the clock spectrum X(s) and is:

$$Y(s) = X(s) \times H_3(s) \times [H_1(s) - H_2(s)]$$

In order to generate time domain jitter numbers, an inverse Fourier Transform is performed on X(s)*H3(s) * [H1(s) - H2(s)].

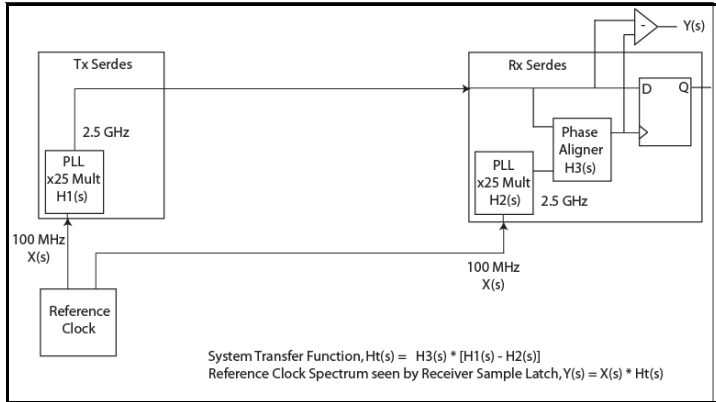

PCI Express Common Clock Architecture

For **PCI Express Gen 1**, one transfer function is defined and the evaluation is performed over the entire spectrum: DC to Nyquist (e.g for a 100MHz reference clock: 0Hz – 50MHz) and the jitter result is reported in peak-peak.

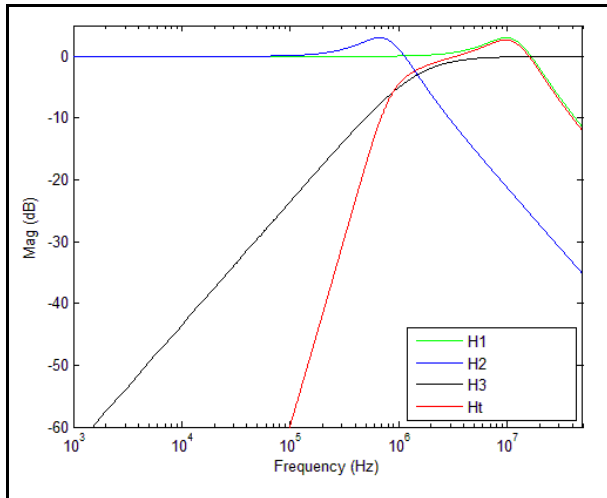

PCI Express Gen 1 Magnitude of Transfer Function

For **PCI Express Gen 2**, two transfer functions are defined with 2 evaluation ranges and the final jitter number is reported in rms. The two evaluation ranges for PCI Express Gen 2 are 10kHz – 1.5MHz (Low Band) and 1.5MHz – Nyquist (High Band). The plots show the individual transfer functions as well as the overall transfer function Ht.

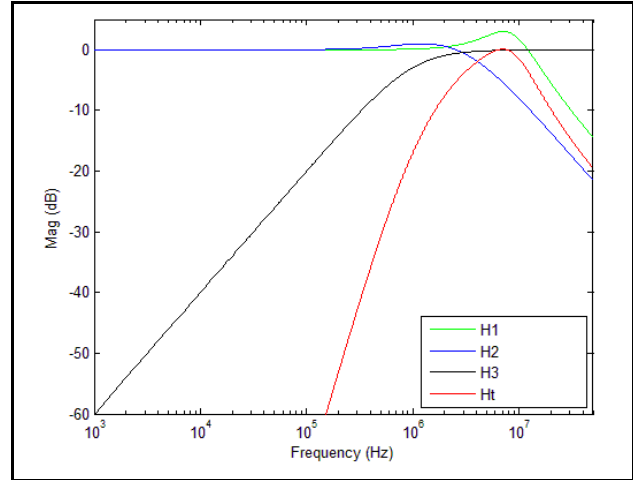

PCI Express Gen 2A Magnitude of Transfer Function

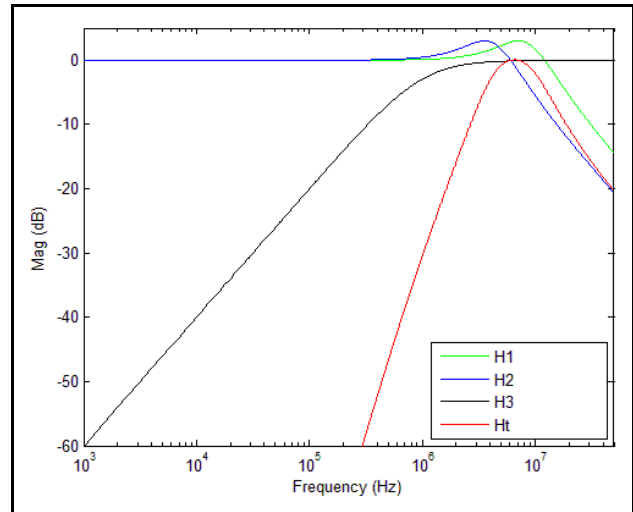

PCI Express Gen 2B Magnitude of Transfer Function

For a more thorough overview of PCI Express jitter analysis methodology, please refer to IDT Application Note *PCI Express Reference Clock Requirements*.

Schematic Layout

Figure 4 shows an example of ICS874001I-05 application schematic. In this example, the device is operated at $V_{DD} = V_{DDA} = V_{DDO} = 3.3V$. The input is driven by a 3.3V LVPECL driver.

As with any high speed analog circuitry, the power supply pins are vulnerable to noise. To achieve optimum jitter performance, power supply isolation is required. The ICS74001I-05 provides separate power supplies to isolate from coupling into the internal PLL.

In order to achieve the best possible filtering, it is recommended that the placement of the filter components be on the device side of the PCB as close to the power pins as possible. If space is limited, the 0.1uF capacitor in each power pin filter should be placed on the device side of the PCB and the other components can be placed on the opposite side.

Power supply filter recommendations are a general guideline to be used for reducing external noise from coupling into the devices. The filter performance is designed for wide range of noise frequencies. This low-pass filter starts to attenuate noise at approximately 10kHz. If a specific frequency noise component is known, such as switching power supply frequencies, it is recommended that component values be adjusted and if required, additional filtering be added. Additionally, good general design practices for power plane voltage stability suggests adding bulk capacitances in the local area of all devices.

The schematic example focuses on functional connections and is not configuration specific. Refer to the pin description and functional tables in the datasheet to ensure the logic control inputs are properly set.

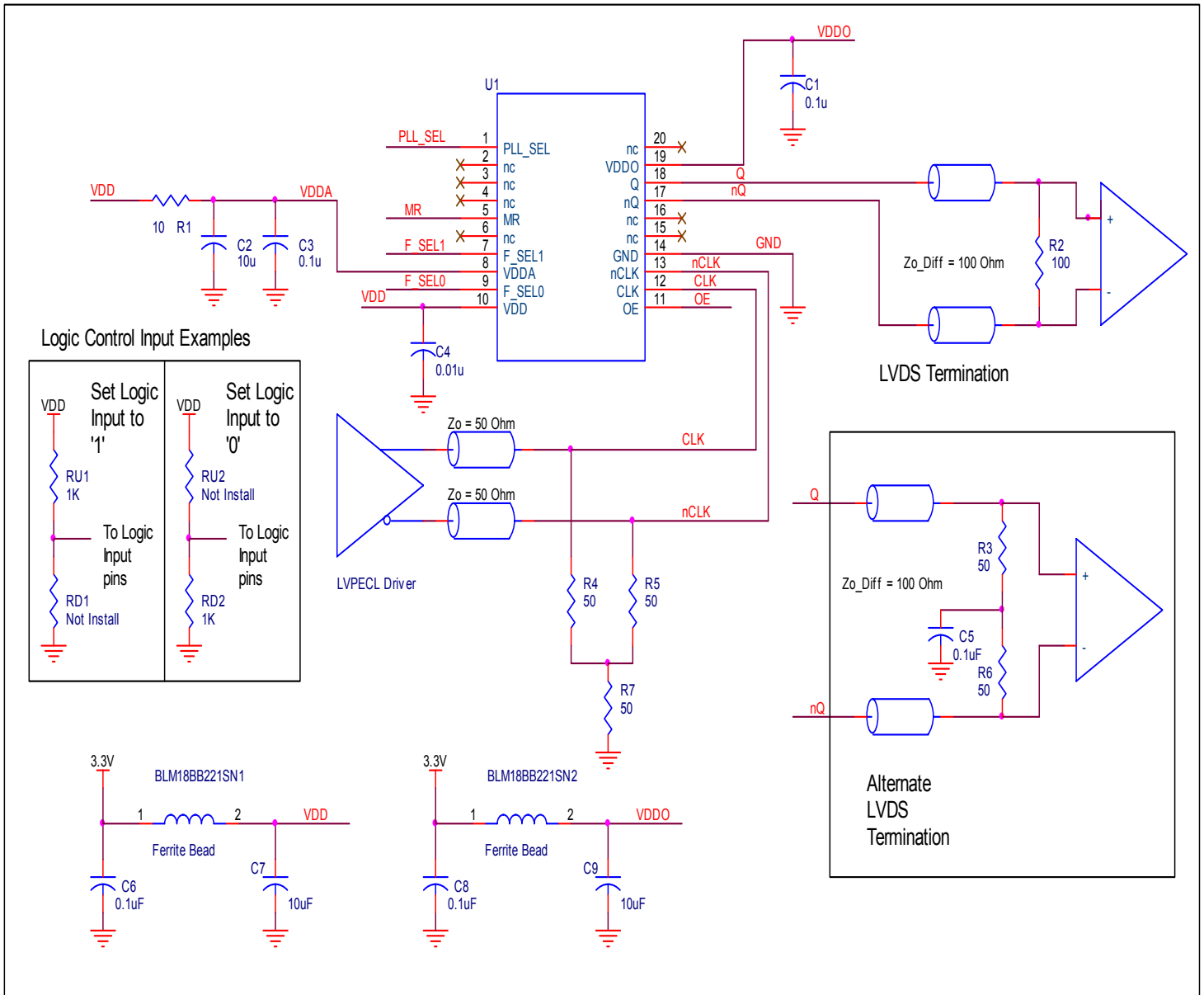

Figure 4. ICS874001I-05 Schematic Layout

Power Considerations

This section provides information on power dissipation and junction temperature for the ICS874001I-05. Equations and example calculations are also provided.

1. Power Dissipation.

The total power dissipation for the ICS874001I-05 is the sum of the core power plus the analog power plus the power dissipated in the load(s). The following is the power dissipation for $V_{DD} = 3.3V + 0.3V = 3.6V$, which gives worst case results.

- Power (core)_{MAX} = $V_{DD_MAX} * (I_{DD_MAX} + I_{DDA_MAX}) = 3.6V * (75mA + 13mA) = \mathbf{316.8mW}$
- Power (outputs)_{MAX} = $V_{DDO_MAX} * I_{DDO_MAX} = 3.6V * 25mA = \mathbf{90mW}$

$$\mathbf{Total\ Power_{MAX} = 316.8mW + 90mW = 406.8mW}$$

2. Junction Temperature.

Junction temperature, T_j , is the temperature at the junction of the bond wire and bond pad directly affects the reliability of the device. The maximum recommended junction temperature is 125°C. Limiting the internal transistor junction temperature, T_j , to 125°C ensures that the bond wire and bond pad temperature remains below 125°C.

The equation for T_j is as follows: $T_j = \theta_{JA} * Pd_{total} + T_A$

T_j = Junction Temperature

θ_{JA} = Junction-to-Ambient Thermal Resistance

Pd_{total} = Total Device Power Dissipation (example calculation is in section 1 above)

T_A = Ambient Temperature

In order to calculate junction temperature, the appropriate junction-to-ambient thermal resistance θ_{JA} must be used. Assuming no air flow and a multi-layer board, the appropriate value is 86.7°C/W per Table 6 below.

Therefore, T_j for an ambient temperature of 85°C with all outputs switching is:

$$85^\circ\text{C} + 0.407\text{W} * 86.7^\circ\text{C/W} = 120.3^\circ\text{C}. \text{ This is below the limit of } 125^\circ\text{C}.$$

This calculation is only an example. T_j will obviously vary depending on the number of loaded outputs, supply voltage, air flow and the type of board (multi-layer).

Table 6. Thermal Resistance θ_{JA} for 20 Lead TSSOP, Forced Convection

| θ_{JA} by Velocity | | | |
|---|----------|----------|----------|
| Meters per Second | 0 | 1 | 2.5 |
| Multi-Layer PCB, JEDEC Standard Test Boards | 86.7°C/W | 82.4°C/W | 80.2°C/W |

Reliability Information

Table 7. θ_{JA} vs. Air Flow Table for a 20 Lead TSSOP

| θ_{JA} by Velocity | | | |
|---|----------|----------|----------|
| Meters per Second | 0 | 1 | 2.5 |
| Multi-Layer PCB, JEDEC Standard Test Boards | 86.7°C/W | 82.4°C/W | 80.2°C/W |

Transistor Count

The transistor count for ICS874001I-05 is: 1,608

Package Outline and Package Dimensions

Package Outline - G Suffix for 20 Lead TSSOP

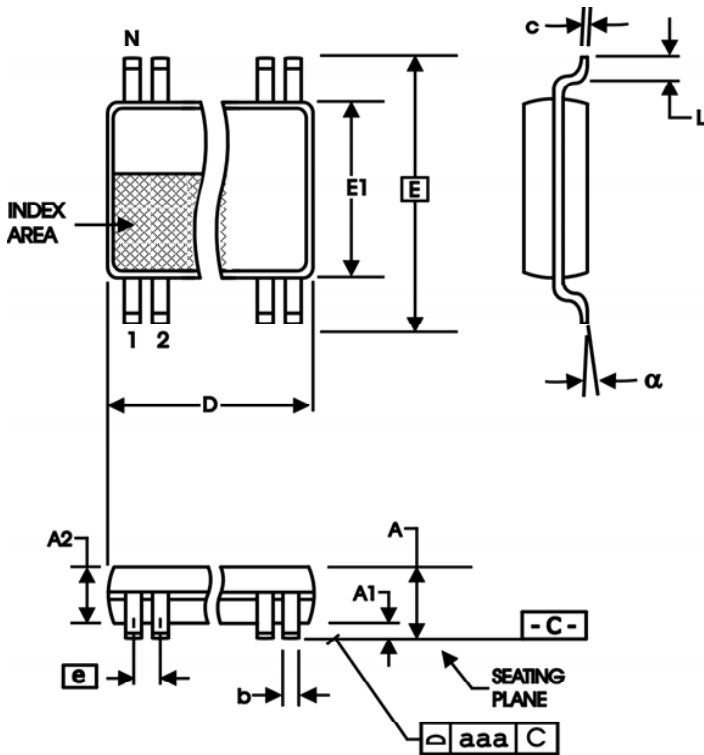

Table 8 Package Dimensions

| All Dimensions in Millimeters | | |
|-------------------------------|------------|---------|
| Symbol | Minimum | Maximum |
| N | 20 | |
| A | | 1.20 |
| A1 | 0.05 | 0.15 |
| A2 | 0.80 | 1.05 |
| b | 0.19 | 0.30 |
| c | 0.09 | 0.20 |
| D | 6.40 | 6.60 |
| E | 6.40 Basic | |
| E1 | 4.30 | 4.50 |
| e | 0.65 Basic | |
| L | 0.45 | 0.75 |
| α | 0° | 8° |
| aaa | | 0.10 |

Reference Document: JEDEC Publication 95, MO-153

Ordering Information

Table 9. Ordering Information

| Part/Order Number | Marking | Package | Shipping Packaging | Temperature |
|-------------------|--------------|---------------------------|--------------------|---------------|
| 874001AGI-05LF | ICS4001AI05L | "Lead-Free" 20 Lead TSSOP | Tube | -40°C to 85°C |
| 874001AGI-05LFT | ICS4001AI05L | "Lead-Free" 20 Lead TSSOP | 2500 Tape & Reel | -40°C to 85°C |

NOTE: Parts that are ordered with an "LF" suffix to the part number are the Pb-Free configuration and are RoHS compliant.

Revision History Sheet

| Rev | Table | Page | Description of Change | Date |
|-----|-------|------|--|---------|
| A | T5 | 6 | Updated HCSL notes. | 1/14/11 |
| | | 9 | Deleted <i>Power Supply Filtering Techniques</i> application note (see schematic application). Updated <i>Wiring the Differential Input to Accept Single-ended Levels</i> application note. | |
| | | 11 | Updated <i>LVDS Driver Termination</i> application note. | |
| | | 12 | Update <i>PCI Express Application Note</i> . | |
| | | 13 | Updated <i>Schematic Layout</i> application Note and diagram. Converted datasheet format. | |

IMPORTANT NOTICE AND DISCLAIMER

RENESAS ELECTRONICS CORPORATION AND ITS SUBSIDIARIES (“RENESAS”) PROVIDES TECHNICAL SPECIFICATIONS AND RELIABILITY DATA (INCLUDING DATASHEETS), DESIGN RESOURCES (INCLUDING REFERENCE DESIGNS), APPLICATION OR OTHER DESIGN ADVICE, WEB TOOLS, SAFETY INFORMATION, AND OTHER RESOURCES “AS IS” AND WITH ALL FAULTS, AND DISCLAIMS ALL WARRANTIES, EXPRESS OR IMPLIED, INCLUDING, WITHOUT LIMITATION, ANY IMPLIED WARRANTIES OF MERCHANTABILITY, FITNESS FOR A PARTICULAR PURPOSE, OR NON-INFRINGEMENT OF THIRD PARTY INTELLECTUAL PROPERTY RIGHTS.

These resources are intended for developers skilled in the art designing with Renesas products. You are solely responsible for (1) selecting the appropriate products for your application, (2) designing, validating, and testing your application, and (3) ensuring your application meets applicable standards, and any other safety, security, or other requirements. These resources are subject to change without notice. Renesas grants you permission to use these resources only for development of an application that uses Renesas products. Other reproduction or use of these resources is strictly prohibited. No license is granted to any other Renesas intellectual property or to any third party intellectual property. Renesas disclaims responsibility for, and you will fully indemnify Renesas and its representatives against, any claims, damages, costs, losses, or liabilities arising out of your use of these resources. Renesas' products are provided only subject to Renesas' Terms and Conditions of Sale or other applicable terms agreed to in writing. No use of any Renesas resources expands or otherwise alters any applicable warranties or warranty disclaimers for these products.

(Disclaimer Rev.1.0 Mar 2020)

Corporate Headquarters

TOYOSU FORESIA, 3-2-24 Toyosu,
Koto-ku, Tokyo 135-0061, Japan
www.renesas.com

Contact Information

For further information on a product, technology, the most up-to-date version of a document, or your nearest sales office, please visit:
www.renesas.com/contact/

Trademarks

Renesas and the Renesas logo are trademarks of Renesas Electronics Corporation. All trademarks and registered trademarks are the property of their respective owners.