



FAST CMOS OCTAL BUFFER/LINE DRIVER

IDT74FCT2244AT/CT

FEATURES:

- A and C grades
- Low input and output leakage $\leq 1\mu\text{A}$ (max.)
- CMOS power levels
- True TTL input and output compatibility:
 - $V_{OH} = 3.3V$ (typ.)
 - $V_{OL} = 0.3V$ (typ.)
- Meets or exceeds JEDEC standard 18 specifications
- Resistor outputs (-15mA IOH, 12mA IOL)
- Reduced system switching noise
- Available in SOIC and QSOP packages

DESCRIPTION:

The IDT octal buffer/line driver is built using an advanced dual metal CMOS technology. The FCT2244T is designed to be employed as a memory and address driver, clock driver, and bus-oriented transmitter/receiver which provides improved board density.

The FCT2244T has balanced output drive with current limiting resistors. This offers low ground bounce, minimal undershoot, and controlled output fall times, reducing the need for external series terminating resistors. The FCT2244T is a plug-in replacement for the FCT244T.

FUNCTIONAL BLOCK DIAGRAM

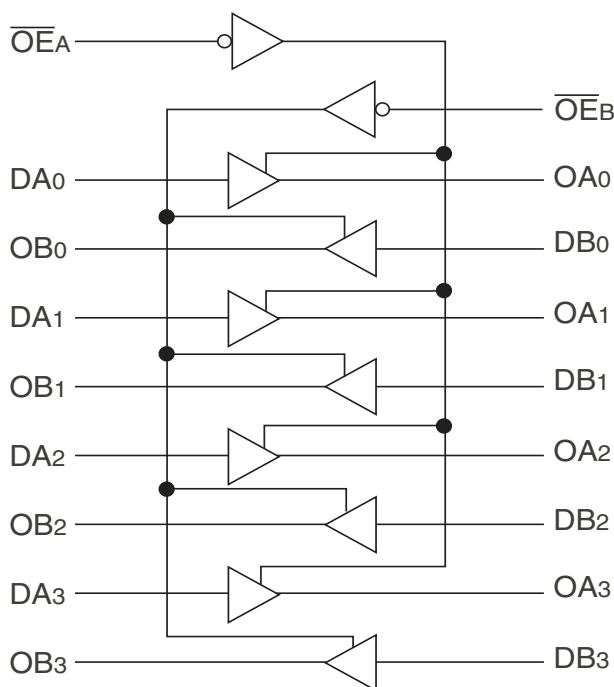

PIN CONFIGURATION

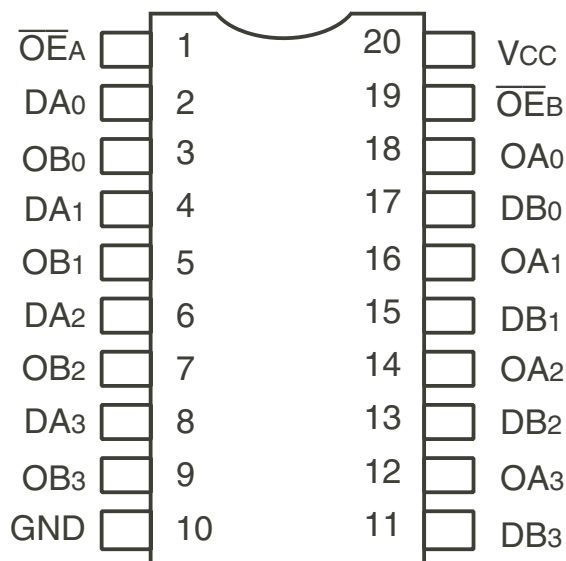

SOIC / QSOP
TOP VIEW

ABSOLUTE MAXIMUM RATINGS⁽¹⁾

Symbol	Description	Max	Unit
V _{TERM} ⁽²⁾	Terminal Voltage with Respect to GND	-0.5 to +7	V
V _{TERM} ⁽³⁾	Terminal Voltage with Respect to GND	-0.5 to V _{CC} +0.5	V
T _{STG}	Storage Temperature	-65 to +150	°C
I _{OUT}	DC Output Current	-60 to +120	mA

NOTES:

- Stresses greater than those listed under ABSOLUTE MAXIMUM RATINGS may cause permanent damage to the device. This is a stress rating only and functional operation of the device at these or any other conditions above those indicated in the operational sections of this specification is not implied. Exposure to absolute maximum rating conditions for extended periods may affect reliability. No terminal voltage may exceed V_{CC} by +0.5V unless otherwise noted.
- Inputs and V_{CC} terminals only.
- Output and I/O terminals only.

CAPACITANCE (T_A = +25°C, F = 1.0MHz)

Symbol	Parameter ⁽¹⁾	Conditions	Typ.	Max.	Unit
C _{IN}	Input Capacitance	V _{IN} = 0V	6	10	pF
C _{OUT}	Output Capacitance	V _{OUT} = 0V	8	12	pF

NOTE:

- This parameter is measured at characterization but not tested.

PIN DESCRIPTION

Pin Names	Description
\overline{OE}_A , \overline{OE}_B	3-State Output Enable Inputs (Active LOW)
Dxx	Inputs
Oxx	Outputs

FUNCTION TABLE⁽¹⁾

Inputs			Outputs
\overline{OE}_A	\overline{OE}_B	D	
L	L	L	L
L	L	H	H
H	H	X	Z

NOTE:

- H = HIGH Voltage Level
X = Don't Care
L = LOW Voltage Level
Z = High Impedance

DC ELECTRICAL CHARACTERISTICS OVER OPERATING RANGE

Following Conditions Apply Unless Otherwise Specified:

Industrial: $T_A = -40^{\circ}\text{C}$ to $+85^{\circ}\text{C}$, $V_{CC} = 5.0\text{V} \pm 5\%$

Symbol	Parameter	Test Conditions ⁽¹⁾		Min.	Typ. ⁽²⁾	Max.	Unit
V_{IH}	Input HIGH Level	Guaranteed Logic HIGH Level		2	—	—	V
V_{IL}	Input LOW Level	Guaranteed Logic LOW Level		—	—	0.8	V
I_{IH}	Input HIGH Current ⁽⁴⁾	$V_{CC} = \text{Max.}$	$V_I = 2.7\text{V}$	—	—	± 1	μA
I_{IL}	Input LOW Current ⁽⁴⁾	$V_{CC} = \text{Max.}$	$V_I = 0.5\text{V}$	—	—	± 1	μA
I_{OZH}	High Impedance Output Current (3-State Output Pins) ⁽⁴⁾	$V_{CC} = \text{Max.}$	$V_I = 2.7\text{V}$	—	—	± 1	μA
I_{OZL}			$V_I = 0.5\text{V}$	—	—	± 1	
I_I	Input HIGH Current ⁽⁴⁾	$V_{CC} = \text{Max.}, V_I = V_{CC} (\text{Max.})$		—	—	± 1	μA
V_{IK}	Clamp Diode Voltage	$V_{CC} = \text{Min.}, I_{IN} = -18\text{mA}$		—	-0.7	-1.2	V
V_H	Input Hysteresis	—		—	200	—	mV
I_{CC}	Quiescent Power Supply Current	$V_{CC} = \text{Max.}$ $V_{IN} = \text{GND or } V_{CC}$		—	0.01	1	mA

OUTPUT DRIVE CHARACTERISTICS

Symbol	Parameter	Test Conditions ⁽¹⁾		Min.	Typ. ⁽²⁾	Max.	Unit
I_{ODL}	Output LOW Current	$V_{CC} = 5\text{V}, V_{IN} = V_{IH} \text{ or } V_{IL}, V_{OUT} = 1.5\text{V}^{(3)}$		16	48	—	mA
I_{ODH}	Output HIGH Current	$V_{CC} = 5\text{V}, V_{IN} = V_{IH} \text{ or } V_{IL}, V_{OUT} = 1.5\text{V}^{(3)}$		-16	-48	—	mA
V_{OH}	Output HIGH Voltage	$V_{CC} = \text{Min}$ $V_{IN} = V_{IH} \text{ or } V_{IL}$	$I_{OH} = -15\text{mA}$	2.4	3.3	—	V
V_{OL}	Output LOW Voltage	$V_{CC} = \text{Min}$ $V_{IN} = V_{IH} \text{ or } V_{IL}$	$I_{OL} = 12\text{mA}$	—	0.3	0.5	V

NOTES:

1. For conditions shown as Min. or Max., use appropriate value specified under Electrical Characteristics for the applicable device type.
2. Typical values are at $V_{CC} = 5.0\text{V}$, $+25^{\circ}\text{C}$ ambient.
3. Not more than one output should be tested at one time. Duration of the test should not exceed one second.
4. The test limit for this parameter is $\pm 5\mu\text{A}$ at $T_A = -55^{\circ}\text{C}$.

POWER SUPPLY CHARACTERISTICS

Symbol	Parameter	Test Conditions ⁽¹⁾		Min.	Typ. ⁽²⁾	Max.	Unit
ΔI_{CC}	Quiescent Power Supply Current TTL Inputs HIGH	V _{CC} = Max. V _{IN} = 3.4V ⁽³⁾		—	0.5	2	mA
I _{CCD}	Dynamic Power Supply Current ⁽⁴⁾	V _{CC} = Max. Outputs Open \overline{OE}_A or \overline{OE}_B = GND One Input Toggling 50% Duty Cycle	V _{IN} = V _{CC} V _{IN} = GND	—	0.06	0.12	mA/ MHz
I _C	Total Power Supply Current ⁽⁶⁾	V _{CC} = Max. Outputs Open f _i = 10MHz 50% Duty Cycle \overline{OE}_A or \overline{OE}_B = GND One Bit Toggling	V _{IN} = V _{CC} V _{IN} = GND	—	0.6	2.2	mA
			V _{IN} = 3.4V V _{IN} = GND	—	0.9	3.2	
		V _{CC} = Max. Outputs Open f _i = 2.5MHz 50% Duty Cycle \overline{OE}_A or \overline{OE}_B = GND Four Bits Toggling	V _{IN} = V _{CC} V _{IN} = GND	—	1.2	3.4 ⁽⁵⁾	
			V _{IN} = 3.4V V _{IN} = GND	—	3.2	11.4 ⁽⁵⁾	

NOTES:

- For conditions shown as Min. or Max., use appropriate value specified under Electrical Characteristics for the applicable device type.
- Typical values are at V_{CC} = 5.0V, +25°C ambient.
- Per TTL driven input (V_{IN} = 3.4V). All other inputs at V_{CC} or GND.
- This parameter is not directly testable, but is derived for use in Total Power Supply Calculations.
- Values for these conditions are examples of ΔI_{CC} formula. These limits are guaranteed but not tested.
- I_C = I_{QUIESCENT} + I_{INPUTS} + I_{DYNAMIC}
I_C = I_{CC} + ΔI_{CC} D_{HNT} + I_{CCD} (f_{CP}/2 + f_iN_i)
I_{CC} = Quiescent Current
 ΔI_{CC} = Power Supply Current for a TTL High Input (V_{IN} = 3.4V)
D_H = Duty Cycle for TTL Inputs High
N_T = Number of TTL Inputs at D_H
I_{CCD} = Dynamic Current caused by an Input Transition Pair (HLH or LHL)
f_{CP} = Clock Frequency for Register Devices (Zero for Non-Register Devices)
f_i = Output Frequency
N_i = Number of Outputs at f_i

All currents are in milliamps and all frequencies are in megahertz.

SWITCHING CHARACTERISTICS OVER OPERATING RANGE

Symbol	Parameter	Condition ⁽¹⁾	74FCT2244AT		74FCT2244CT		Unit
			Min. ⁽²⁾	Max.	Min. ⁽²⁾	Max.	
t _{PLH}	Propagation Delay	C _L = 50pF R _L = 500Ω	1.5	4.8	1.5	4.1	ns
t _{PHL}	Dx to Ox						
t _{PZH}	Output Enable Time		1.5	6.2	1.5	5.8	
t _{PZL}	Output Disable Time						
t _{PHZ}			1.5	5.6	1.5	5.2	ns
t _{PLZ}							

NOTES:

- See test circuit and waveforms.
- Minimum limits are guaranteed but not tested on Propagation Delays.

TEST CIRCUITS AND WAVEFORMS

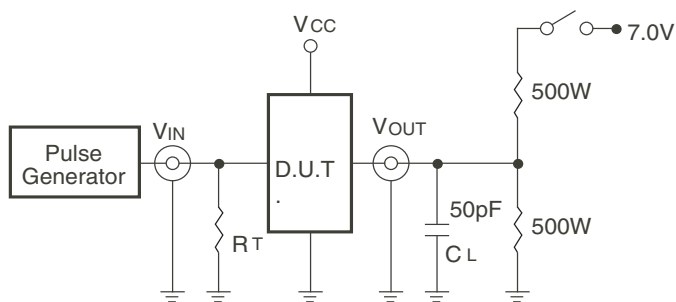

Octal Link

Test Circuits for All Outputs

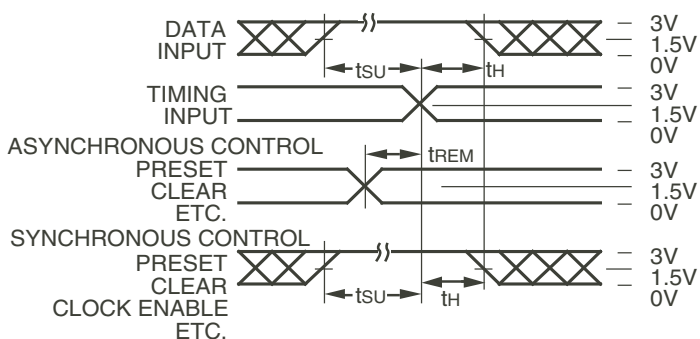

Octal Link

Set-Up, Hold, and Release Times

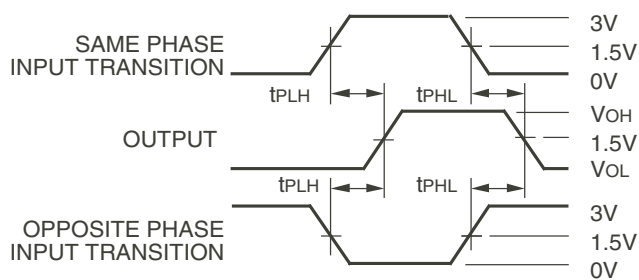

Octal Link

Propagation Delay

SWITCH POSITION

Test	Switch
Open Drain Disable Low Enable Low	Closed
All Other Tests	Open

DEFINITIONS:

CL = Load capacitance: includes jig and probe capacitance.
RT = Termination resistance: should be equal to ZOUT of the Pulse Generator.

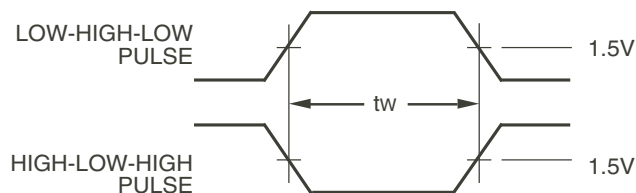

Pulse Width

Octal Link

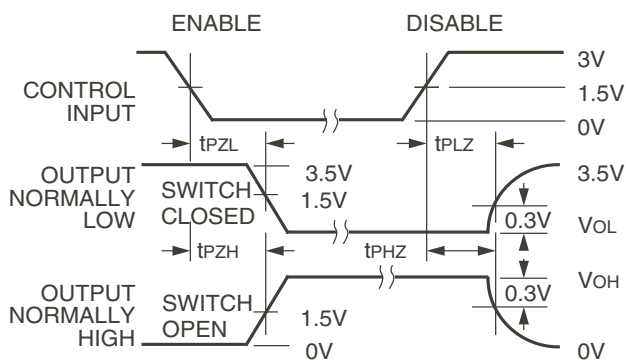

Octal Link

Enable and Disable Times

NOTES:

- Diagram shown for input Control Enable-LOW and input Control Disable-HIGH.
- Pulse Generator for All Pulses: Rate \leq 1.0MHz; $t_f \leq$ 2.5ns; $t_r \leq$ 2.5ns.

ORDERING INFORMATION

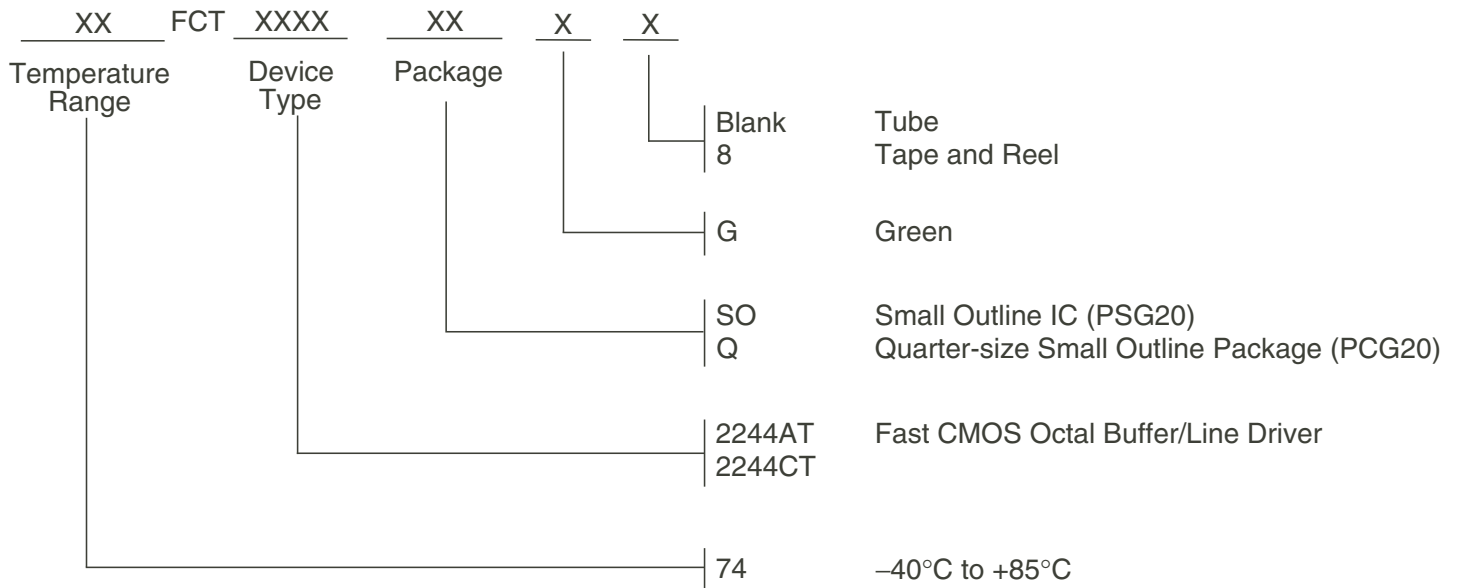

Datasheet Document History

09/28/2009	Pg. 6	Updated the ordering information by removing the "IDT" notation and non RoHS part.
09/26/2011	Pg. 2,6	Correct Outputs in Function Table. Updated ordering information to include tube or tray and tape & reel.
11/26/2016	Pg. 6	Updated ordering information diagram temperature symbol, removed tray and created Green option in greater detail.



CORPORATE HEADQUARTERS
 6024 Silver Creek Valley Road
 San Jose, CA 95138

for SALES:
 800-345-7015 or 408-284-8200
 fax: 408-284-2775
 www.idt.com

for Tech Support:
 logichelp@idt.com