

3M™ TWIN AXIAL PCI EXPRESS X16 EXTENDER ASSEMBLIES GEN 4.0, 8KCH SERIES

BILL OF MATERIALS			
ITEM	DESCRIPTION	QTY	
1.0	PBA PCB ASSY, PADDLECARD, PCIE X16	1	
1.1	PCB PCIE X16 (164 POS) STRADDLEMOUNT 3M P/N: 78-9102-7845-2	1	
1.2	CONN CONNECTOR, PCIE (164 POS) STRADDLEMOUNT X16	1	
2.0	PCB PCIE X16 EXTENDER (164 POS) CARD-EDGE 3M P/N: 78-9102-7851-0	1	
3.0	CABLE RIBBON TWINAX CABLE 3M P/N: SL8802/22-15FN5-00	AS REQUIRED	
4.0	CABLE RIBBON CABLE, 20 POSITION 3M P/N: HF447-20	AS REQUIRED	
5.0	STRAIN RELIEF ADHESIVE	AS REQUIRED	
6.0	LABEL SEE ASSEMBLY PART DETAIL	1	

ORDERING INFORMATION

8KCH-0965-XXXX

STANDARD LENGTHS DIM. "A"
 0250 = [250 MM]
 0500 = [500 MM]

NOTE:
 NON-STANDARD LENGTHS AVAILABLE UPON REQUEST.
 MAY REQUIRE HIGHER MOQ'S AND LONGER LEAD TIMES.

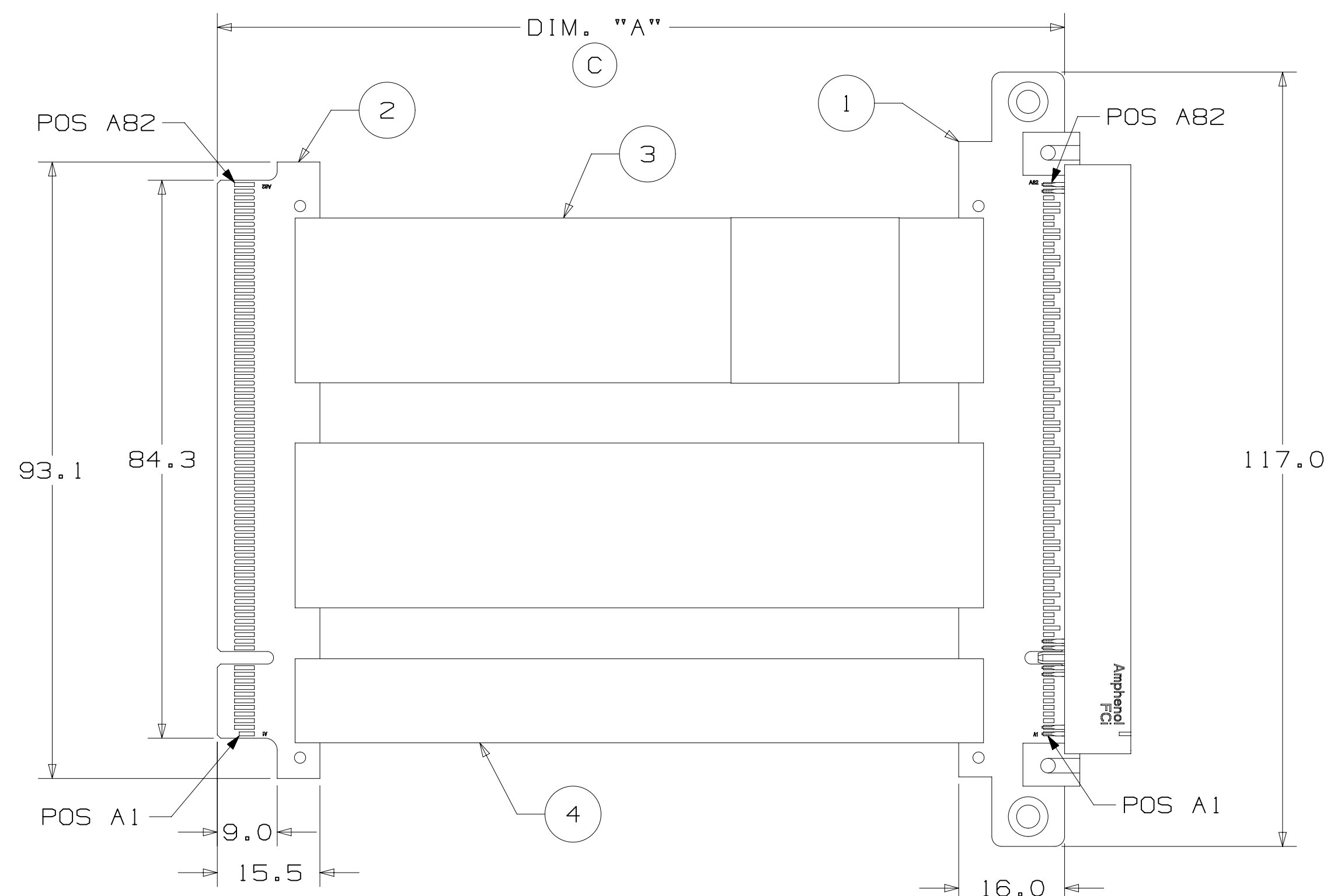
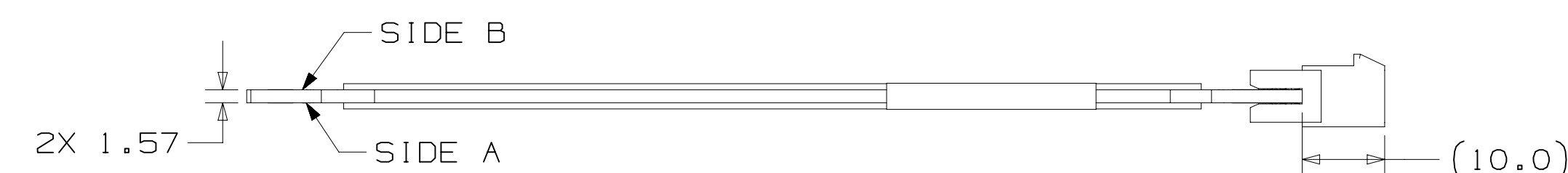
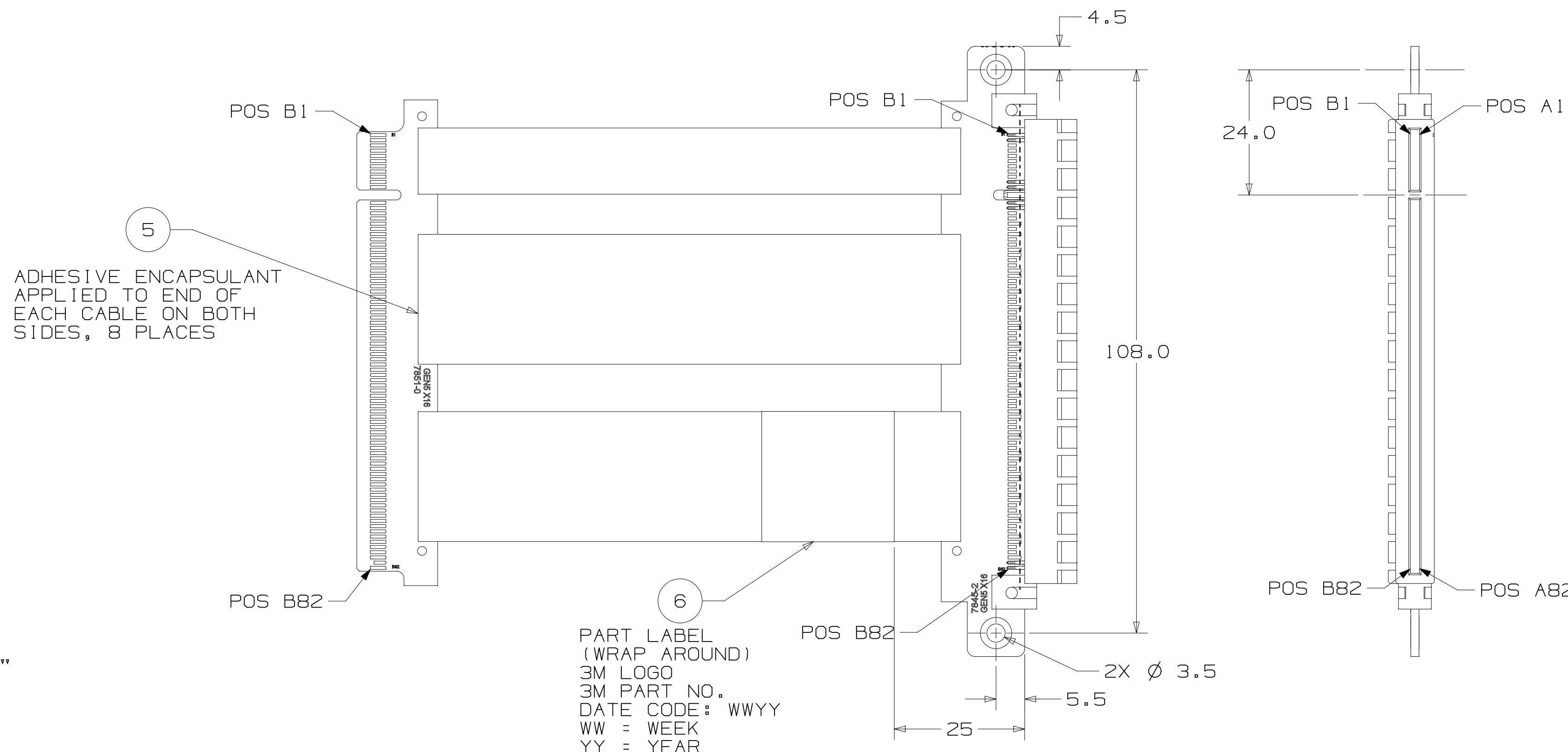
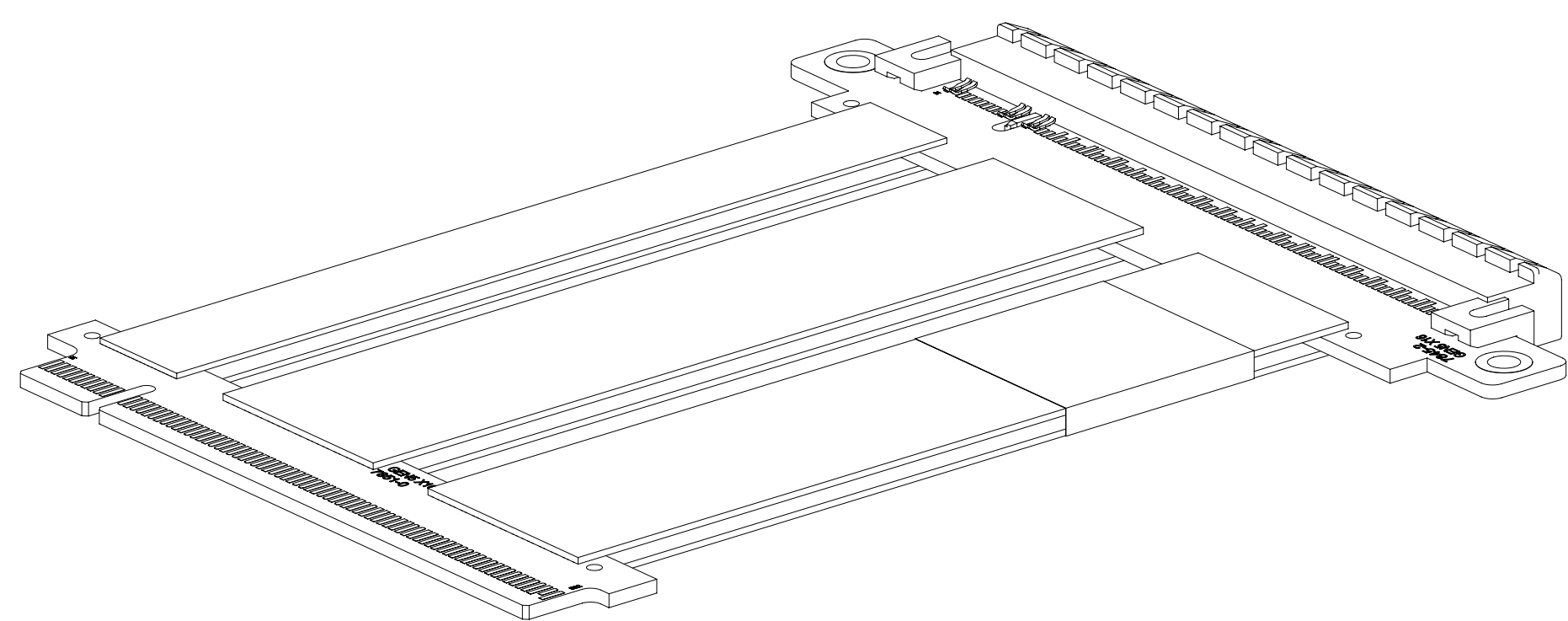

- NOTES
- DIMENSIONS ARE IN MILLIMETERS.
 - 3M TWIN AXIAL CABLE DESCRIPTION:
 30 AWG, SILVER PLATED SIGNAL WIRE
 IMPEDANCE: 85 ± 5 OHM
 OVERALL RIBBON WIDTH: 24.90 MM
 OVERALL RIBBON THICKNESS: 0.75 MM
 - REGULATORY INFORMATION:
 VISIT 3M.com/regs OR CONTACT YOUR 3M REPRESENTATIVE TO FIND THE ROHS COMPLIANCE STATUS OF THE 3M PART YOU ARE INTERESTED IN.
 - THIS CABLE CONSTRUCTION HAS A THIN ALUMINUM LAYER AT EACH EDGE. USER SHOULD EVALUATE ITS USE IN THEIR APPLICATION AND, IF NECESSARY, INSULATING TAPE MAY BE APPLIED TO COVER THE ALUMINUM LAYER, AS USER DEEMS APPROPRIATE.
 - PRODUCT SPECIFICATION: PS-0390.
 - FLAMMABILITY RATING
 - TWINAX/AUX RIBBONS: UL94 HB
 HORIZONTAL FLAME
 TEST FOR INTERNAL WIRING
 -PCBS: UL94V-0
 - PADDLECARD PLATING:
 30μ" MIN. GOLD PLATING
 50μ" MIN. NICKEL UNDERPLATING.
 - UNLESS OTHERWISE NOTED, REFERENCES TO INDUSTRY SPECIFICATIONS ARE INTENDED TO INDICATE SUBSTANTIAL COMPLIANCE TO THE MATERIAL ELEMENTS OF THE SPECIFICATION. SUCH REFERENCES SHOULD NOT BE CONSTRUED AS A GUARANTEE OF COMPLIANCE TO ALL REQUIREMENTS IN A GIVEN SPECIFICATION.
 - CLOTH TAPE WRAPPED AROUND CABLE RIBBONS AT BACK OF EACH CONNECTOR. ALSO, UP TO TWO ADDITIONAL TAPE PIECES WILL BE WRAPPED AROUND THE TWO CABLE RIBBONS SPACED EQUIDISTANT FROM THE CONNECTOR ENDS AND EACH OTHER, DEPENDING ON ASSY LENGTH (L):
 L <= 0.2M: NO ADDITIONAL TAPE
 0.2M < L <= 0.6M: 1 TAPE WRAP
 0.6M < L <= 1.0M: 2 TAPE WRAP
 - LENGTH TOLERANCE:
 ± 5MM FOR LENGTHS LESS THAN 0.5M.
 ± 8MM FOR LENGTHS 0.5 TO 1.0 METER.
 - (X) DENOTES ITEM FIND NUMBER IN TABLE 1: BILL OF MATERIALS.
 - (C) DENOTES CRITICAL DIMENSION.

3M ELECTRONICS MATERIALS SOLUTIONS DIVISION
 INTERCONNECT SOLUTIONS
<http://www.3m.com/TwinAx>

3M IS A TRADEMARK OF 3M COMPANY.
 FOR TECHNICAL, SALES OR ORDERING
 INFORMATION CALL 800-225-5373

DESIGN REFERENCE	NEXT ASSEMBLY	REV	ECO	ISSUE DATE AND DESCRIPTION	DRFT	CHKD
		L	SCHMIDT	SEP 01, 2020	MFG	DATE
		M	LETTANG	AUG 15, 2022	APPL	DATE
DIVISION		EMSD		© 3M COPYRIGHT 2022 This document and the information it contains are 3M property and may not be reproduced or further distributed without 3M permission, or used or disclosed other than for 3M authorized purposes. All rights reserved.		
DO NOT SCALE DRAWING		SCALE	TOLERANCES EXCEPT AS NOTED INCHES .00 ± .000 ± .0000 ±			
THIRD ANGLE PROJECTION		MILLIMETERS		INTERPRET PER ASME Y14.5 - 2018 0 ± .1 .0 ± .05 .000 ± .005		
MAX SURFACE ROUGHNESS		SURFACES		CAGE NUMBER D 78-5100-2716-8		
MARKED ONLY		ANGLES		MODEL SHT 1 OF 2		
A 0106397		AUG 15, 2022		LDS		MML
		WORK REQUEST 13204				
		PRODUCTION RELEASE				
TITLE		8KCH-0965-XXXX CABLE ASSY, X16 GEN 4.0 STRADDLEMOUNT, PCIE				
CAGE NUMBER		D 78-5100-2716-8				
MODEL		SHT 1 OF 2				

78-5100-2716-8
 DRAWING NUMBER
 REV. 6
 Time 8/15/2022 -- UTC
 Drf-set (hrs) 6
 Imaged: Central Standard

3M™ TWIN AXIAL PCI EXPRESS X16 EXTENDER ASSEMBLIES GEN 4.0,
8KCH SERIES

Edgecard pin #	Side B Description	Name	CEM pin #
B01	+12 volt power	+12v	B01
B02	+12 volt power	+12v	B02
B03	+12 volt power	+12v	B03
B04	Ground	GND	B04
B05	SMBus clock	SMCLK	B05
B06	SMBus data	SMDAT	B06
B07	Ground	GND	B07
B08	+3.3 volt power	+3.3v	B08
B09	+TRST#	JTAG1	B09
B10	3.3v auxiliary power	3.3Vaux	B10
B11	Link Reactivation	WAKE#	B11
Mechanical Key			
B12	Clock Request Signal	CLKREQ#	B12
B13	Ground	GND	B13
B14	Transmitter Lane 0, Differential pair	PETp(0)	B14
B15	Ground	PETn(0)	B15
B16	Ground	GND	B16
B17	Presence detect	PRSNT2#	B17
B18	Ground	GND	B18
B19	Transmitter Lane 1, Differential pair	PETp(1)	B19
B20	Ground	PETn(1)	B20
B21	Ground	GND	B21
B22	Ground	GND	B22
B23	Transmitter Lane 2, Differential pair	PETp(2)	B23
B24	Ground	PETn(2)	B24
B25	Ground	GND	B25
B26	Ground	GND	B26
B27	Transmitter Lane 3, Differential pair	PETp(3)	B27
B28	Ground	PETn(3)	B28
B29	Ground	GND	B29
B30	Emergency Pwr Reduct	PWRBRK#	B30
B31	Presence detect	PRSNT2#	B31
B32	Ground	GND	B32
B33	Transmitter Lane 4, Differential pair	PETp(4)	B33
B34	Ground	PETn(4)	B34
B35	Ground	GND	B35
B36	Ground	GND	B36
B37	Transmitter Lane 5, Differential pair	PETp(5)	B37
B38	Ground	PETn(5)	B38
B39	Ground	GND	B39
B40	Ground	GND	B40
B41	Transmitter Lane 6, Differential pair	PETp(6)	B41
B42	Ground	PETn(6)	B42
B43	Ground	GND	B43
B44	Ground	GND	B44
B45	Transmitter Lane 7, Differential pair	PETp(7)	B45
B46	Ground	PETn(7)	B46
B47	Ground	GND	B47
B48	Presence detect	PRSNT2#	B48
B49	Ground	GND	B49
B50	Transmitter Lane 8, Differential pair	PETp(8)	B50
B51	Ground	PETn(8)	B51
B52	Ground	GND	B52
B53	Ground	GND	B53
B54	Transmitter Lane 9, Differential pair	PETp(9)	B54
B55	Ground	PETn(9)	B55
B56	Ground	GND	B56
B57	Ground	GND	B57
B58	Transmitter Lane 10, Differential pair	PETp(10)	B58
B59	Ground	PETn(10)	B59
B60	Ground	GND	B60
B61	Ground	GND	B61
B62	Transmitter Lane 11, Differential pair	PETp(11)	B62
B63	Ground	PETn(11)	B63
B64	Ground	GND	B64
B65	Ground	GND	B65
B66	Transmitter Lane 12, Differential pair	PETp(12)	B66
B67	Ground	PETn(12)	B67
B68	Ground	GND	B68
B69	Ground	GND	B69
B70	Transmitter Lane 13, Differential pair	PETp(13)	B70
B71	Ground	PETn(13)	B71
B72	Ground	GND	B72
B73	Ground	GND	B73
B74	Transmitter Lane 14, Differential pair	PETp(14)	B74
B75	Ground	PETn(14)	B75
B76	Ground	GND	B76
B77	Ground	GND	B77
B78	Transmitter Lane 15, Differential pair	PETp(15)	B78
B79	Ground	PETn(15)	B79
B80	Ground	GND	B80
B81	Hot plug present detect	PRSNT2#	B81
B82	Presence detect	RSVD#2	B82

Edgecard pin #	Side A Description	Name	CEM pin #
A01	Presence detect	PRSNT#1	A01
A02	+12 volt power	+12v	A02
A03	+12 volt power	+12v	A03
A04	Ground	GND	A04
A05	TCK	JTAG2	A05
A06	TDI	JTAG3	A06
A07	TDO	JTAG4	A07
A08	TMS	JTAG5	A08
A09	+3.3 volt power	+3.3v	A09
A10	+3.3 volt power	+3.3v	A10
A11	Fundamental reset	PERST#	A11
Mechanical Key			
A12	Ground	GND	A12
A13	Reference Clock, Differential pair	REFCLK+	A13
A14	Ground	REFCLK-	A14
A15	Ground	GND	A15
A16	Receiver Lane 0, Differential pair	PERp(0)	A16
A17	Ground	PERn(0)	A17
A18	Ground	GND	A18
A19	Manufacturer Test Mode	MFG	A19
A20	Ground	GND	A20
A21	Receiver Lane 1, Differential pair	PERp(1)	A21
A22	Ground	PERn(1)	A22
A23	Ground	GND	A23
A24	Ground	GND	A24
A25	Receiver Lane 2, Differential pair	PERp(2)	A25
A26	Ground	PERn(2)	A26
A27	Ground	GND	A27
A28	Ground	GND	A28
A29	Receiver Lane 3, Differential pair	PERp(3)	A29
A30	Ground	PERn(3)	A30
A31	Ground	GND	A31
A32	Reserved	RSVD	A32
A33	Reserved	RSVD	A33
A34	Ground	GND	A34
A35	Receiver Lane 4, Differential pair	PERp(4)	A35
A36	Ground	PERn(4)	A36
A37	Ground	GND	A37
A38	Ground	GND	A38
A39	Receiver Lane 5, Differential pair	PERp(5)	A39
A40	Ground	PERn(5)	A40
A41	Ground	GND	A41
A42	Ground	GND	A42
A43	Receiver Lane 6, Differential pair	PERp(6)	A43
A44	Ground	PERn(6)	A44
A45	Ground	GND	A45
A46	Ground	GND	A46
A47	Receiver Lane 7, Differential pair	PERp(7)	A47
A48	Ground	PERn(7)	A48
A49	Ground	GND	A49
A50	Reserved	RSVD	A50
A51	Ground	GND	A51
A52	Receiver Lane 8, Differential pair	PERp(8)	A52
A53	Ground	PERn(8)	A53
A54	Ground	GND	A54
A55	Ground	GND	A55
A56	Receiver Lane 9, Differential pair	PERp(9)	A56
A57	Ground	PERn(9)	A57
A58	Ground	GND	A58
A59	Ground	GND	A59
A60	Receiver Lane 10, Differential pair	PERp(10)	A60
A61	Ground	PERn(10)	A61
A62	Ground	GND	A62
A63	Ground	GND	A63
A64	Receiver Lane 11, Differential pair	PERp(11)	A64
A65	Ground	PERn(11)	A65
A66	Ground	GND	A66
A67	Ground	GND	A67
A68	Receiver Lane 12, Differential pair	PERp(12)	A68
A69	Ground	PERn(12)	A69
A70	Ground	GND	A70
A71	Ground	GND	A71
A72	Receiver Lane 13, Differential pair	PERp(13)	A72
A73	Ground	PERn(13)	A73
A74	Ground	GND	A74
A75	Ground	GND	A75
A76	Receiver Lane 14, Differential pair	PERp(14)	A76
A77	Ground	PERn(14)	A77
A78	Ground	GND	A78
A79	Ground	GND	A79
A80	Receiver Lane 15, Differential pair	PERp(15)	A80
A81	Ground	PERn(15)	A81
A82	Ground	GND	A82

ALL GROUNDS ARE TIED TOGETHER IN PCBs

Regulatory: For regulatory information about this product, visit 3M.com/regs or contact your 3M representative.

Technical Information: The technical information, recommendations and other statements contained in this document are based upon tests or experience that 3M believes are reliable, but the accuracy or completeness of such information is not guaranteed.

Product Use: Many factors beyond 3M's control and uniquely within user's control can affect the use and performance of a 3M product in a particular application. Given the variety of factors that can affect the use and performance of a 3M product, user is solely responsible for evaluating the 3M product and determining whether it is fit for a particular purpose and suitable for user's method of application.

Warranty, Limited Remedy, and Disclaimer: Unless an additional warranty is specifically stated on the applicable 3M product packaging or product literature, 3M warrants that each 3M product meets the applicable 3M product specification at the time 3M ships the product. 3M MAKES NO OTHER WARRANTIES OR CONDITIONS, EXPRESS OR IMPLIED, INCLUDING, BUT NOT LIMITED TO, ANY IMPLIED WARRANTY OR CONDITION OF MERCHANTABILITY OR FITNESS FOR A PARTICULAR PURPOSE OR ANY IMPLIED WARRANTY OR CONDITION ARISING OUT OF A COURSE OF DEALING, CUSTOM OR USAGE OR TRADE. If the 3M product does not conform to this warranty, then the sole and exclusive remedy is, at 3M's option, replacement of the 3M product or refund of the purchase price.

Limitation of Liability: Except where prohibited by law, 3M will not be liable for any loss or damage arising from the 3M product, whether direct, indirect, special, incidental or consequential, regardless of the legal theory asserted, including warranty, contract, negligence or strict liability.

3M Company
Electronics Materials Solutions Division
13011 McCallen Pass, Bldg. C
Austin, TX 78753-5380
1-800-225-5373
www.3M.com/interconnect

DESIGN REFERENCE	NEXT ASSEMBLY	REV	ECO	ISSUE DATE AND DESCRIPTION	DRFT	CHKD
				AUG 15, 2022 WORK REQUEST 13204 PRODUCTION RELEASE	LDS	MML
APPROVED	DATE	DATE	DATE	DATE	DATE	DATE
DIVISION		DIVISION CODE		DATE		
EMSD		EMSD		SEP 01, 2020		
DO NOT SCALE DRAWING		SCALE		TOLERANCES EXCEPT AS NOTED		
1		1		INCHES		
THIRD ANGLE PROJECTION		INTERPRET PER ASME Y14.5 - 2018		MILLIMETERS		
MAX SURFACE ROUGHNESS		SURFACES		0 ± .1		
MARKED ONLY		SURFACES		.00 ± .05		
		SURFACES		.000 ± .005		
		SURFACES		ANGLES		
		SURFACES		CAGE NUMBER		
		SURFACES		D 78-5100-2716-8		
		SURFACES		DRAWING NO.		
		SURFACES		78-5100-2716-8		
		SURFACES		REV.		
		SURFACES		A		
		SURFACES		MODEL		
		SURFACES		SHT 2 OF 2		

78-5100-2716-8
 DRAWING NUMBER
 6
 REV. 1
 DATE 8/15/2022
 TIME 11:58 AM
 UTC
 Drr-set
 Imaged: Central Standard