

LOC		DIST		ZONE		LTR		REVISIONS		
BD	77	P	F				J	DESCRIPTION	DATE	APPD
								OBSOLETE -2	01-17-2007	SB
								PER ECO-07-000087		

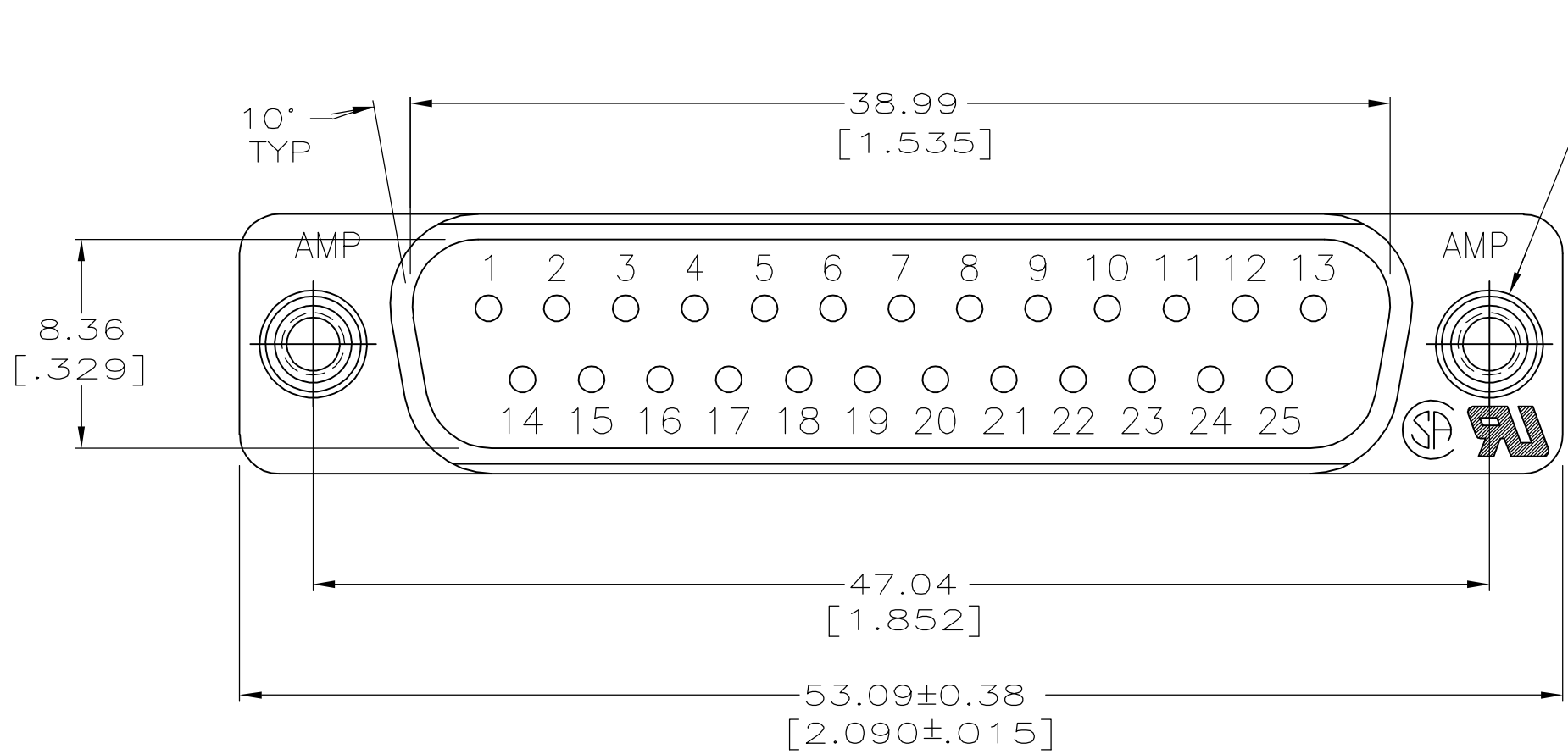

- ① HOUSING: BLACK POLYESTER, UL 94V-0 RATED; CONTACT: BRASS PER MIL-C-50; SCREWLOCK: BRASS PER QQ-B-626.
- ② GOLD PLATING PER MIL-G-45204, TIN PLATING PER MIL-T-10727, NICKEL PLATING PER QQ-N-290, COPPER PLATING PER MIL-C-14550.
- ③ GOLD PLATED FOR A LENGTH OF 3.81 [.150] MIN FROM MATING END, GOLD FLASH IN MATED AREA, 2.54µm [.000100] MIN TIN OR TIN-LEAD FOR A LENGTH OF DIMENSION A FROM OPPOSITE END, ALL OVER 1.27µm [.000050] MIN NICKEL.
- ④ GOLD PLATED FOR A LENGTH OF 3.81 [.150] FROM MATING END, 0.76µm [.000030] MIN GOLD IN MATED AREA, 2.54µm [.000100] MIN TIN OR TIN-LEAD FOR A LENGTH OF DIMENSION A FROM OPPOSITE END, ALL OVER 1.27µm [.000050] MIN NICKEL.
- ⑤ 1.27µm [.000050] MIN NICKEL OVER COPPER FLASH.

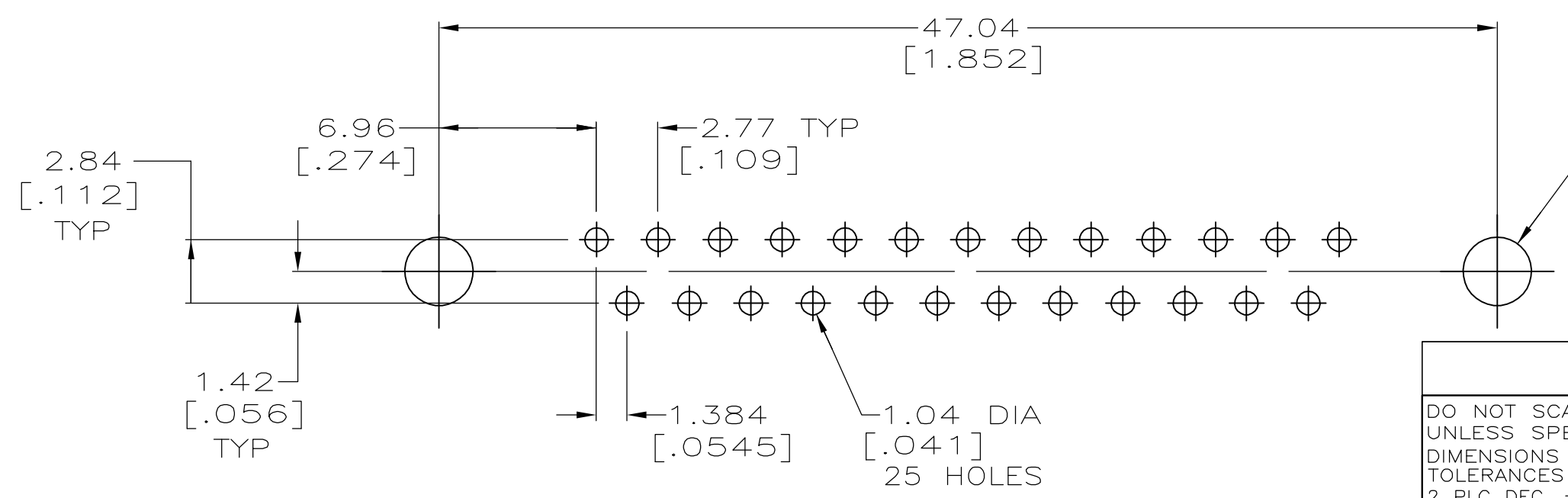
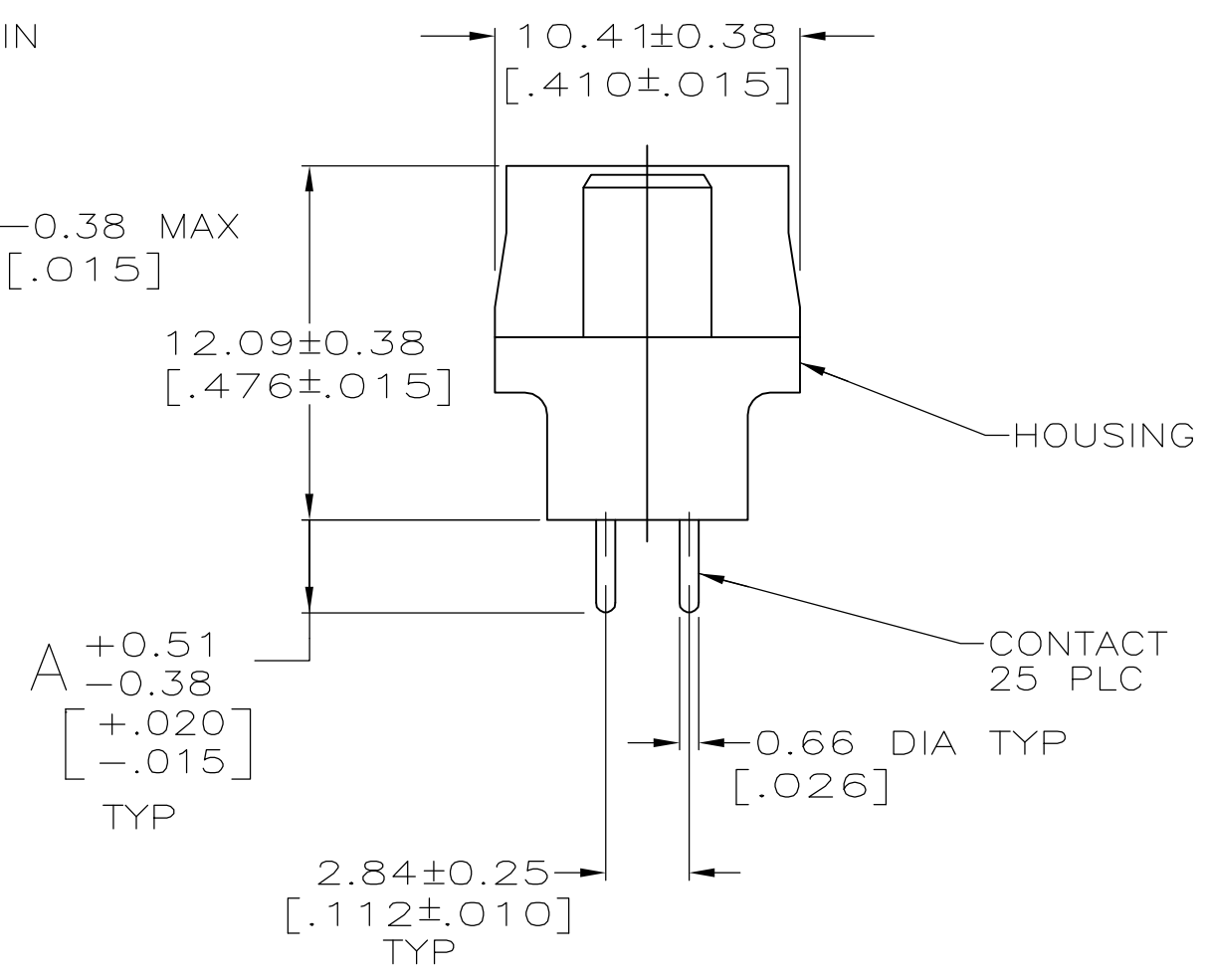
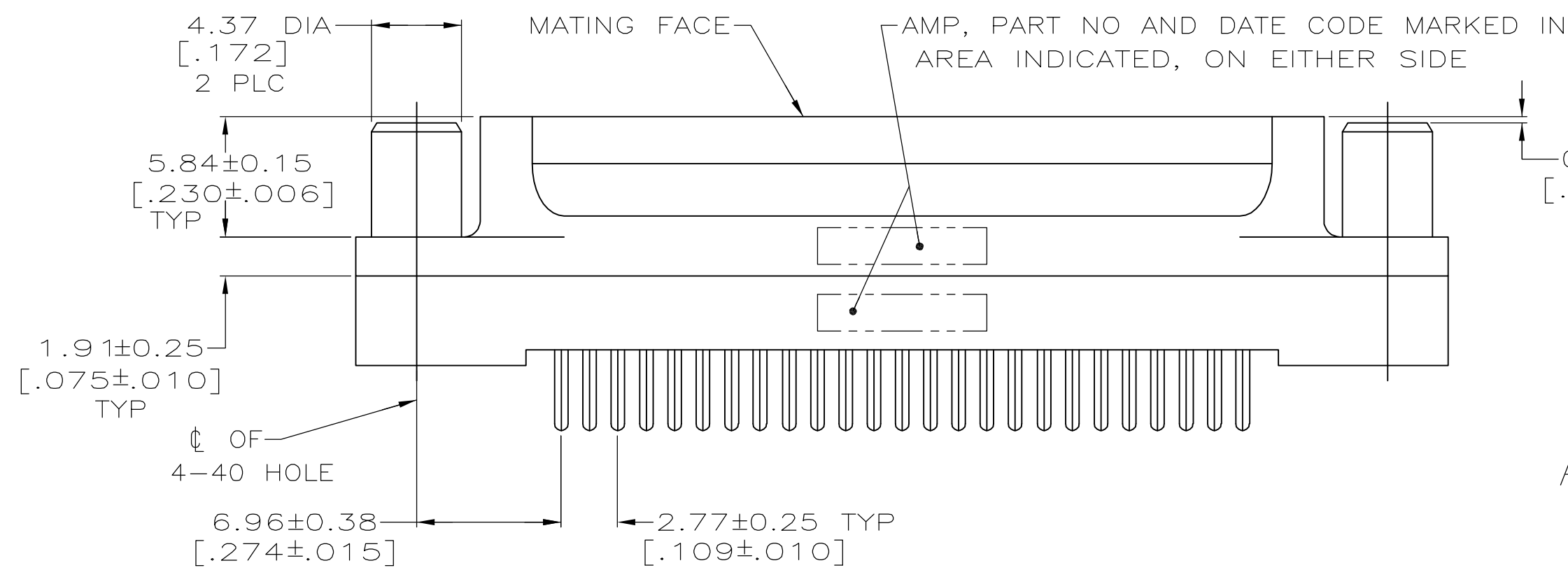

OBSOLETE	6.35 [.250]	④	745073-6
OBSOLETE	6.35 [.250]	③	745073-5
OBSOLETE	4.32 [.170]	④	745073-4
	4.32 [.170]	③	745073-3
OBSOLETE	3.18 [.125]	④	745073-2
	3.18 [.125]	③	745073-1

RECOMMENDED PC BOARD MOUNTING DIMENSIONS

DO NOT SCALE PRINT. UNLESS SPECIFIED DIMENSIONS IN mm [INCHES] TOLERANCES ON : 2 PLC DEC ± 0.13 [.005] 3 PLC DEC ± - ANGLES ± 2°	DR 11-14-89 J McCLINTON CHK 2-2-90 R.STONE APPD 2-2-90 S.SCHIEFERLY APPD 2-2-90 C.ROHDE PRODUCT SPEC 108-40025	NAME <b>AMP</b> AMP INCORPORATED Harrisburg, Pa. 17105 PLUG ASSEMBLY, SIZE 3, 25 POSN, VERTICAL, AMPLIMITE® HD-20
MATERIAL ①	FINISH ② CONTACT: SEE TABLE SCREWLOCK: ⑤	SIZE <b>C</b> CAGE CODE 00779 DRAWING NO 745073
	APPLICATION SPEC -	SCALE 4:1
	WEIGHT -	SHEET 1 OF 1