

PART NUMBER	REV	FIRST USED	POWER UNIT	FEED TYPE	DESCRIPTION
1855321-1	B	122500-1	LEADMAKER	AIR FEED	CUTS CARRIER
1855321-2	B	565435-5	BENCH MODEL K	AIR FEED	CUTS CARRIER
1855321-3	B	354500-1	BENCH MODEL G	AIR FEED	CUTS CARRIER
1855321-6	B	122500-1	LEADMAKER	AIR FEED	CONTINUOUS CARRIER
7-1855321-7	B	-	-	-	SPARE PARTS

- △ RECOMMENDED SPARE PARTS
- △ GREASE LIGHTLY
- △ GUARD MUST BE IN PLACE WHEN OPERATING APPLICATOR IN A BENCH MACHINE

4. TERMINAL LUBRICANT IS RECOMMENDED.

*** WARNING**
ON INSTALLATION, SET WIRE DISC TO LARGEST WIRE SIZE SETTING. USE OF SETTINGS BELOW MIN. REQUIRED CRIMP HEIGHT SETTING WILL CAUSE DAMAGE TO CRIMP TOOLING.

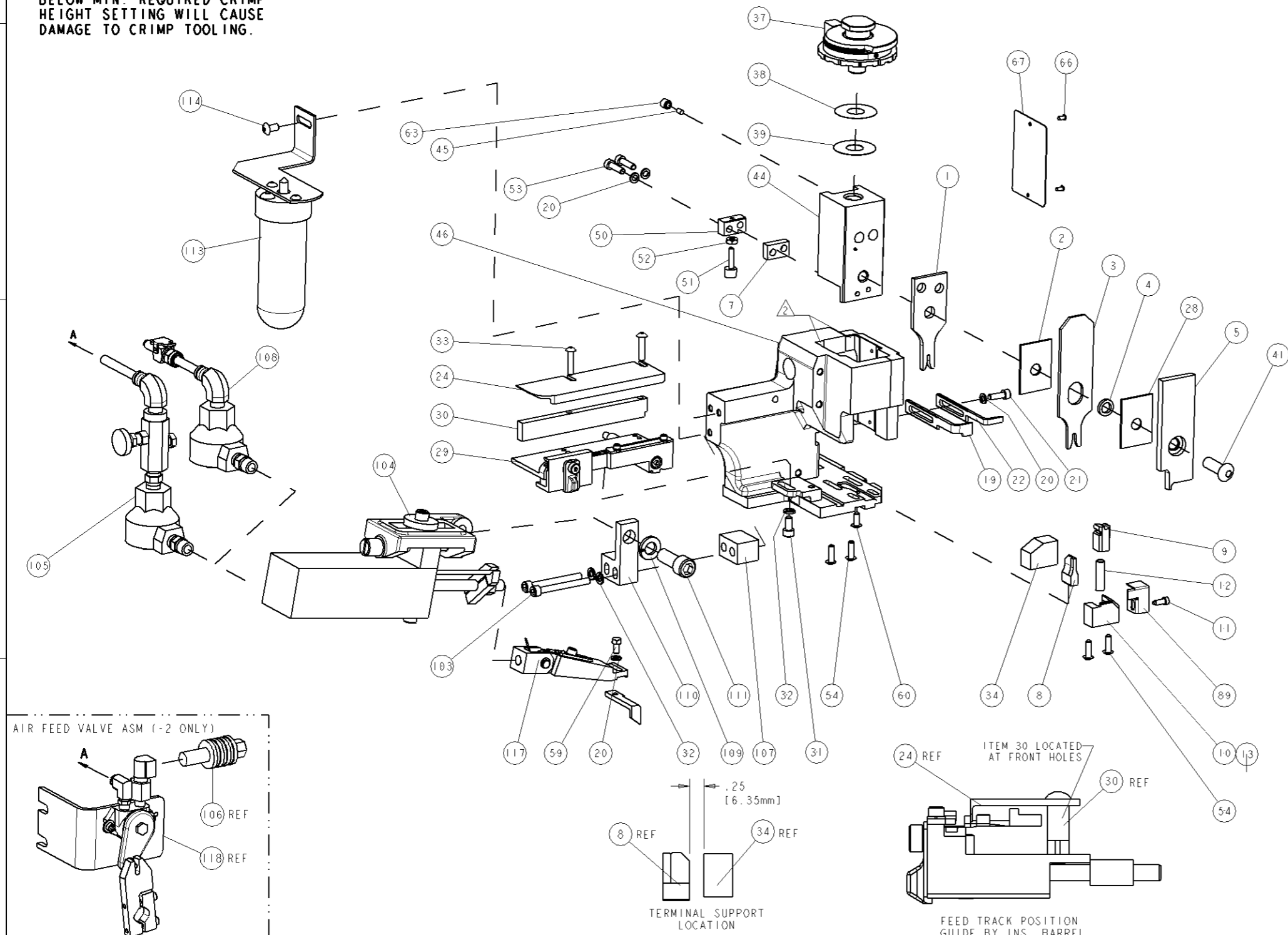

AMP 4801 REV 31MAR2000

TERMINAL NAME: TERMINAL		LEARN TERMINAL - TE CRIMP SPECS		REF SETTING
TE PN	MFG PN	CRIMP HEIGHT	WIRE SIZE	
1949010-1	361830-YF-200	-	-	B8
-	-	1.68±0.05mm [0.066±.002]	18AWG	C2
-	-	1.63±0.05mm [0.064±.002]	0.75mm ²	C9
-	-	1.55±0.05mm [0.061±.002]	20AWG	D0
-	-	1.53±0.05mm [0.060±.002]	0.5mm ²	
CRIMP	SIZE	TYPE	RANGE	
-	-	-	-	-
-	WIRE	1.78mm [0.070]	F	18-20 AWG OR 0.50-0.75mm ²
-	INSUL	2.79mm [0.110]	F	∅ 2.08 MAX
WIRE STRIP LENGTH	TERM APPL SPEC	FEED	APPLICATOR INSTRUCTIONS	SET UP GAGE
4.67-5.05mm	NONE	24.05mm	408-8040	458637-1

REV	DATE	BY	APPD
B2	15NOV2010	SZ	SX

REV	DATE	BY	APPD	DESCRIPTION	ITEM NO		
-	-	-	-	REF	692655-6	AIR FEED VALVE ASSEMBLY	118
-	-	-	-	REF	461062-1	FEED FINGER ASSEMBLY	117
-	-	-	-	REF	455749-1	GUARD WINDOW	116
-	-	-	-	REF	679532-1	INSERT, GUARD	115
-	-	-	-	-	2-21002-6	SCR, BTN SKT HD CAP 10-32 X .375	114
-	-	-	-	-	1-465184-0	LUBRICATOR ASSY	113
-	-	-	-	-	3-21001-5	SCR, SKT HD CAP 3/8-16 X 1.000	111
-	-	-	-	-	459610-9	MOUNT, FEED BRACKET	110
-	-	-	-	-	21024-8	WASHER, SPRG LOCK, REG 3/8	109
-	-	-	-	-	692655-7	AIR FEED VALVE ASSEMBLY	108
-	-	-	-	-	461690-4	SPACER, AIR FEED	107
-	-	-	-	REF	24024-2	VALVE, SHUT OFF	106
-	-	-	-	-	692655-5	AIR FEED VALVE ASSEMBLY	105
-	-	-	-	-	461065-2	ASSEMBLY, AIR FEED	104
-	2	2	2	-	4-21000-2	SCR, SKT HD CAP 10-32 X 1.750	103
-	-	-	-	-	318563-1	GUARD, FRONT CHIP	89
-	-	-	-	-	4088040	SF APPL INST 408-8040	72
-	-	-	-	-	217238-1	GENERAL INSTRUCTION PKG	71
-	-	-	-	-	461264-5	PLATE, IDENTIFICATION	67
-	2	2	2	-	21017-2	SCREW, DRIVE	66
-	-	-	-	-	21009-2	SCR, SET, SELF LOCKING 1/4-20 X .250	63
-	-	-	-	-	22733-8	SCR, BHSC, SELF-LOCKING, 8-32 X .375	60
-	-	-	-	-	2-22603-0	SCR, HEX HD CAP 8-32 X .312	59
-	-	-	-	-	4-694433-9	FEED PAWL	56
-	4	4	4	-	2-21002-2	SCR, BTN SKT HD CAP 8-32 X .500	54
-	2	2	2	-	2-21000-8	SCR, SKT HD CAP 8-32 X .625	53
-	-	-	-	-	21018-5	NUT, HEX, REG 6-32	52
-	-	-	-	-	811242-2	BUMPER, HOLD DOWN	51
-	-	-	-	-	690753-1	SPACER, TONKER	50
-	-	-	-	-	1633399-1	APPL., BASIC AIR FEED SUB ASSY	46
-	-	-	-	-	690191-1	PLUG, NYLON	45
-	-	-	-	-	455673-1	RAM, SIDE FEED	44
-	-	-	-	-	7-21002-9	SCR, BTN SKT HD CAP 5/16-24 X 1.00	41
-	-	-	-	-	690125-1	SHIM SUB-ASSY	39
-	-	-	-	-	469367-2	SHIM	38
-	-	-	-	-	879103-3	FINE ADJUST HEAD ASSEMBLY	37
-	-	-	-	-	690786-6	TERMINAL SUPPORT	34
-	2	2	2	-	2-21002-4	SCR, BTN SKT HD CAP 8-32 X .750	33
-	3	3	3	-	21024-5	WASHER, SPRG LOCK, REG NO 10	32
-	-	-	-	-	3-21000-4	SCR, SKT HD CAP 10-32 X .375	31
-	-	-	-	-	1320908-3	SPACER, STRIP GUIDE	30
-	-	-	-	-	1633091-2	ASSEMBLY, STRIP GUIDE	29
-	-	-	-	-	1-455888-0	SPACER, CRIMPER	28
-	-	-	-	-	1320928-2	PLATE, STRIP GUIDE	24
-	-	-	-	-	690472-2	STRIPPER	22
-	-	-	-	-	2-21000-7	SCR, SKT HD CAP 8-32 X .500	21
-	4	4	4	-	21024-4	WASHER, SPRG LOCK, REG NO 8	20
-	-	-	-	-	691353-1	STRIPPER	19
-	-	-	-	-	679625-1	SHEAR HOLDER, FRONT (NO CUT)	13
-	-	-	-	-	3-22280-3	SPRING, COMPRESSION	12
-	-	-	-	-	690461-1	STOP, SHEAR	11
-	-	-	-	-	690459-1	SHEAR HOLDER, FRONT	10
-	-	-	-	-	454276-1	FLOATING SHEAR, FRONT	9
-	-	-	-	-	1633108-7	ANVIL, COMBINATION .070	8
-	-	-	-	-	3-240641-5	SPACER	7
-	-	-	-	-	-	-	6
-	-	-	-	-	1-455889-4	DEPRESSOR, SHEAR	5
-	-	-	-	-	238011-8	BLOCK, CRIMPER SPACER	4
-	-	-	-	-	8-456134-7	CRIMPER, INSULATION F PREMIUM	3
-	-	-	-	-	1-455888-3	SPACER, CRIMPER	2
-	-	-	-	-	456404-9	CRIMPER, WIRE PREMIUM	1

DIMENSIONS	TOLERANCES UNLESS OTHERWISE SPECIFIED	DATE	BY	APPD	NAME
INCHES	0.125 ± .001 0.125 ± .001 0.125 ± .001 0.125 ± .001 0.125 ± .001	17SEP2007	C. CHEN	18SEP2007	M. HERR
MATERIAL	FINISH	SCALE	SHEET	OF	REV
		A1	00779	C=1855321	B2

CUSTOMER VIEWABLE ASSEMBLY