

PC Power Supply Supervisors

SG6515

FEATURES OVERVIEW

- Two 12V sense input pins: VS12 and VS12B
- Over Voltage Protection (OVP) for 3.3V, 5V and two 12V
- Over Current Protection (OCP) for 3.3V, 5V and two 12V
- Under Voltage Protection (UVP) for 3.3V, 5V and two 12V
- Open drain output for PGO and FPO pins
- 300mS power good delay
- 300mS turn on delay for 3.3V, 5V and two 12V
- 2.8mS PSON control to FPO turn-off delay
- 48mS PSON control delay
- No lockup during the fast AC power on/off
- Wide supply voltage range from 4V to 15V

For supervisor function, it provides the over voltage protection (OVP) for 3.3V, 5V and two 12V; over current protection (OCP) for 3.3V, 5V and two 12V; under voltage protection (UVP) for 3.3V, 5V and two 12V. When 3.3V, 5V or 12V voltage is decreasing to 2.3V, 3.5V and 9V respectively, the under voltage protection (UVP) function will be enabled. FPO will be set to high to turn off the PWM controller IC. The voltage difference across external current shunt is used for OCP functions. An external resistor can be used to adjust protection threshold.

The power supply is turned on after 48mS delay time when PSON signal is set from high to low. To turn off power supply, PSON signal is set from low to high with the delay time 48mS. The PGI circuitry provides a power-down warning signal for PGO. When PGI input is lower than the internal 1.15V reference voltage, PGO signal is pulled low.

DESCRIPTION

SG6515 is designed to provide the voltage, and current supervisor function, remote on/off (PSON) function, power good (PGO) indicator function, and fault protection (FPO) function for switching power systems.

TYPICAL APPLICATION

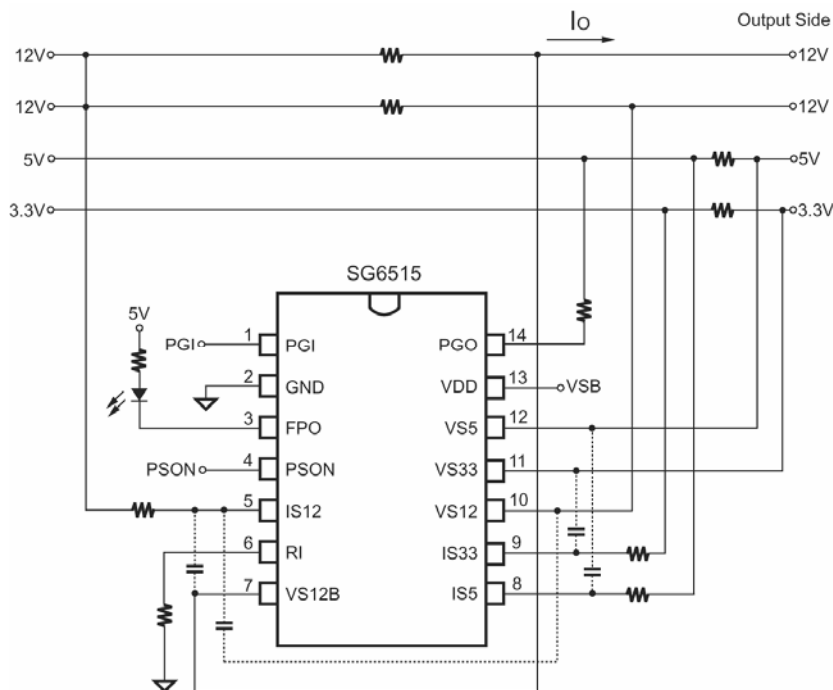

MARKING INFORMATION

T: D = DIP, S = SOP
P: Z = Lead Free
 Null=regular package
XXXXXXXXX: Wafer Lot
Y: Year; **WW:** Week
V: Assembly Location

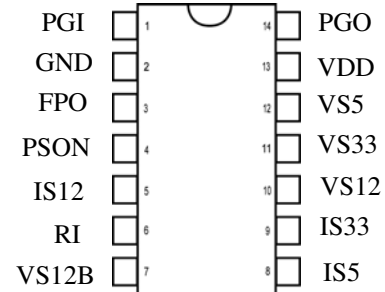
PIN CONFIGURATION

ORDERING INFORMATION

Part Number	Package Type
SG6515DZ	14 pin DIP Plastic (Lead Free)
SG6515SZ	14 pin SOP Plastic (Lead Free)

PIN DESCRIPTIONS

Pin No.	Pin Name	Type	Description
1	PGI	Analog input	Power Good Input. For ATX SMPS, it detects AC line voltage through the main transformer.
2	GND	Supply	Ground.
3	FPO	Logic output	Fault Protection Output. Output signal to control the primary PWM IC through an opto-coupler. When FPO is low, the PWM IC is enabled.
4	PSON	Logic input	Remote On/Off logic input from CPU or main-board. The power supply will be turned on/off after 48mS delay.
5	IS12	Analog input	12V over current protection sense input. For typical application, this pin is connected to the positive end of a current shunt through one resistor. When the voltage on IS12 is higher than that of VS12 by 5mV, OCP will be enabled.
6	RI	Analog input	Reference setting. One external resistor Ri connected between RI and GND pin will determine a reference current, Iref = 1.15/Ri, for OCP programming.
7	VS12B	Analog input	Second 12V over/under-voltage control sense input.
8	IS5	Analog input	5V over current protection sense input.
9	IS33	Analog input	3.3V over current protection sense input.
10	VS12	Analog input	12V over/under-voltage control sense input.
11	VS33	Analog input	3.3V over/under-voltage control sense input.
12	VS5	Analog input	5V over/under-voltage control sense input.
13	VDD	Supply	Supply voltage. 4V ~ 15V. For ATX SMPS, it is connected to 5V-standby and 12V through diodes respectively.
14	PGO	Logic output	Power good logic output, 0 or 1 (open-drain). Power good=1 means that the power supply is good for operation. The power good delay is 300mS.

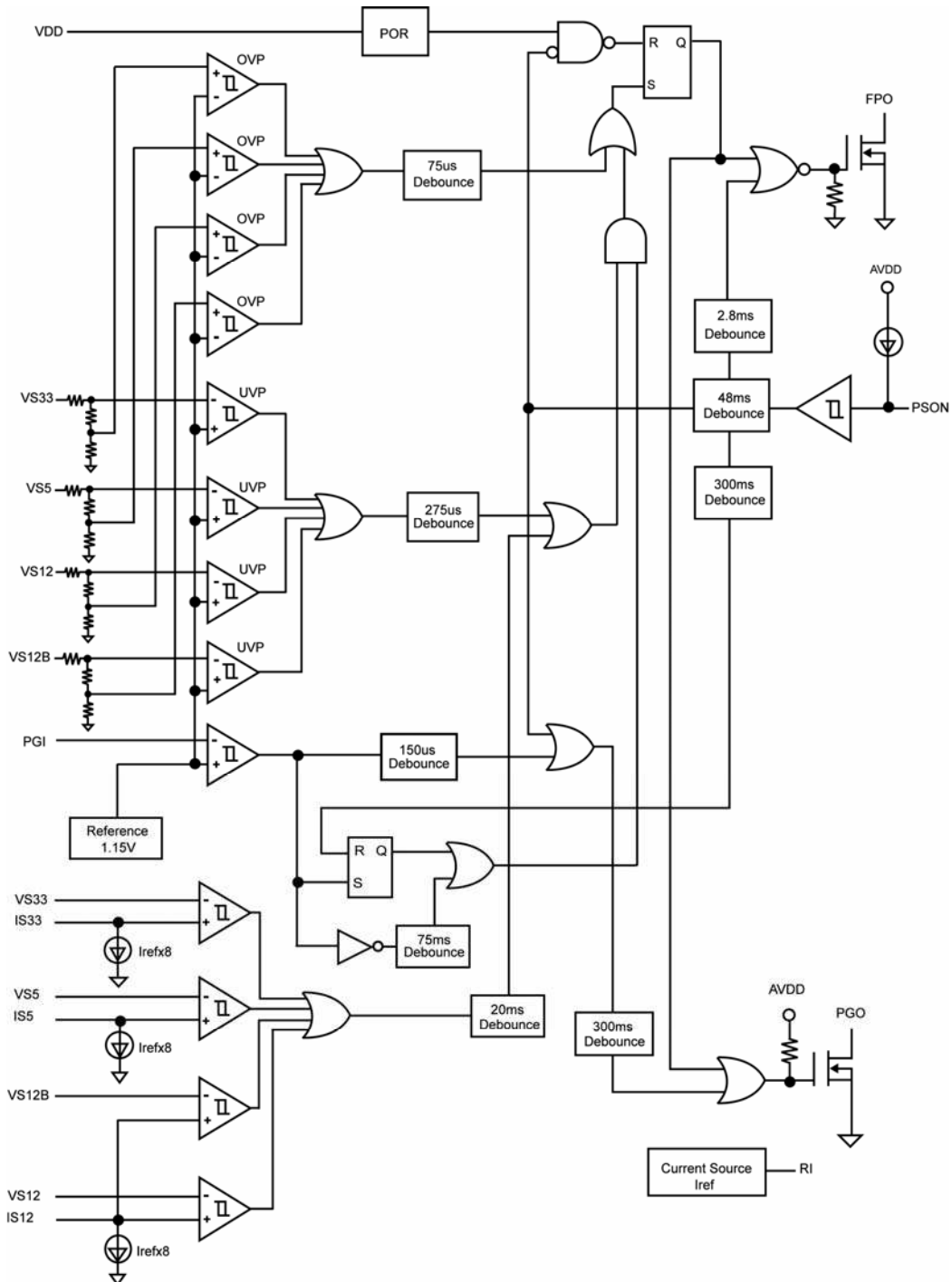
BLOCK DIAGRAM



FUNCTION TABLE

PGI	PSON	UV Protection 12V & OC Protection	OV Protection	FPO	PGO
PGI<1.15V	L	No	No	L	L
PGI<1.15V	L	No	Yes	H	L
PGI<1.15V	L	Yes	No	L	L
PGI<1.15V	L	Yes	Yes	H	L
PGI>1.15V	L	No	No	L	H
PGI>1.15V	L	No	Yes	H	L
PGI>1.15V	L	Yes	No	H	L
PGI>1.15V	L	Yes	Yes	H	L
X	H	X	X	H	L

x = don't care

FPO = L means: fault IS NOT latched

FPO = H means: fault IS latched

PGO = L means: fault

PGO = H means: No fault

TIMING DIAGRAM

PSON On/Off and 3.3V, 5V OVP Function

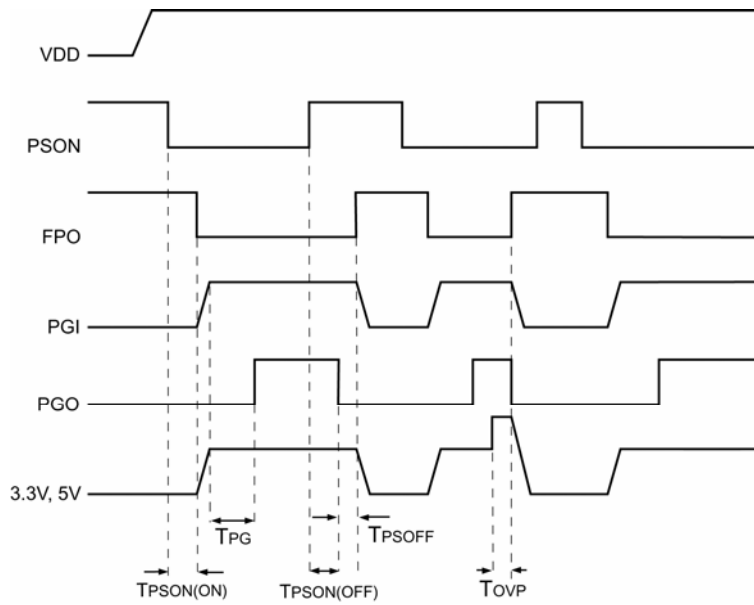

12V OVP/UVP and OCP Function

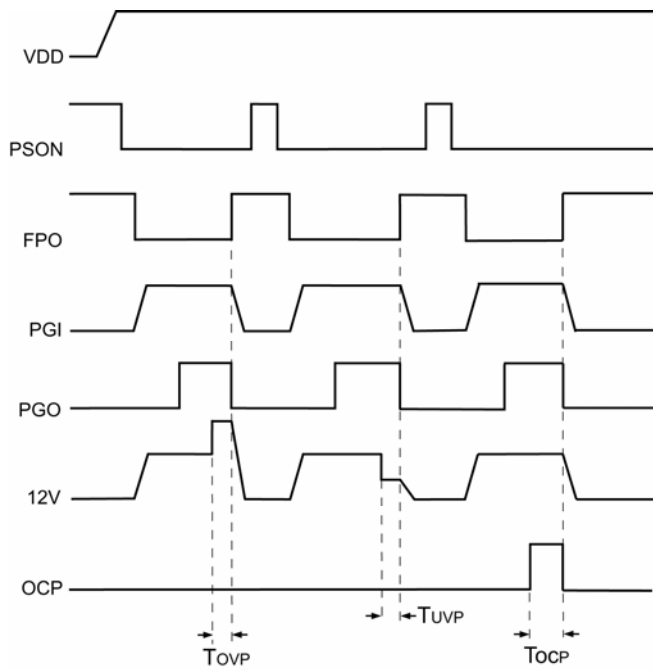

ABSOLUTE MAXIMUM RATINGS

Symbol	Parameter	Min.	Unit
V _{DD}	DC Supply Voltage	16	V
V _I	Input Voltage	PSON, VS33, VS5, PGI, IS33, IS5	-0.3 to 7
	Input Voltage	VS12, VS12B, IS12	-0.3 to 15
V _{OUT}	Output Voltage	FPO, PGO	8
P _D	Power Dissipation	400	mW
T _J	Operating Junction Temperature	-40 to 125	°C
T _{STG}	Storage Temperature Range	-55 to 150	°C
T _L	Lead Temperature (Wave soldering or IR, 10 seconds)	260	°C
	ESD Capability, HBM Model	4.5	KV
	ESD Capability, Machine Model	200	V

* All voltage values, except differential voltages, are given with respect to GND pin.

* Stresses beyond those listed under "absolute maximum ratings" may cause permanent damage to the device.

RECOMMENDED OPERATING CONDITIONS

Symbol	Parameter	Test Conditions	Value	Unit
V _{DD}	DC Supply Voltage		4 to 15	V
T _{OPER}	Operating Ambient Temperature Range		-25 to +85	°C

* For proper operation

ELECTRICAL CHARACTERISTICS (V_{DD}=12V, T_A=25°C, UNLESS NOTED)

VDD Section

Symbol	Parameter	Test Conditions	Min.	Typ.	Max.	Unit
I _{DD1}	Supply Current	PSON = Low		1.7	2.6	mA
I _{DD2}	Supply Current	PSON = High		1.0	1.5	mA
T _R	Supply Voltage Rising Time		1			mS
V _{ST}	VDD Start Threshold Voltage				4.0	V

Over Voltage and Over Current Protection

Symbol	Parameter	Test Conditions	Min.	Typ.	Max.	Unit
V _{OVP}	Over Voltage Protection VS33		3.7	3.9	4.1	V
	Over Voltage Protection VS5		5.7	6.1	6.5	
	Over Voltage Protection VS12, VS12B		13.2	13.8	14.4	
I _{REF}	Ratio of current sense sink current to current sense setting pin (RI) source current	RI = 30 KΩ, 0.1% Resistor	7.6	8	8.4	
V _{OFFSET}	OCP comparator input offset voltage		-5		5	mV
I _{LKG}	Leakage Current (FPO)	V(FPO) = 5V			5	uA
V _{OL}	Low Level Output Voltage (FPO)	Isink 20mA			0.4	V
T _{OVP}	OVP Delay Time		33	75	110	uS
T _{OCP}	OCP Delay Time			125		uS
V _{RI}	RI Pin Voltage		1.138	1.15	1.161	V
I _{RI}	Output Current RI		12.5		62.5	uA
T _{ST-OCP}	Start-up OCP / UVP Protection Time From FPO Low to FPO High	PGI < 1.15V ,FPO=Low	200	300	450	mS

PC Power Supply Supervisors
SG6515
Under Voltage Protection and PGI, PGO

Symbol	Parameter	Test Conditions	Min.	Typ.	Max.	Unit
V _{PGI}	Input Threshold Voltage PGI		1.127	1.15	1.173	V
V _{UVP}	Under Voltage Protection VS33		2.1	2.3	2.5	V
	Under Voltage Protection VS5		3.3	3.5	3.7	
	Under Voltage Protection VS12, VS12B		8.5	9.0	9.5	
T _{OND}	Under Voltage Turn-on Delay Time		49	75	114	mS
T _{UVP}	UVP Delay Time	PGI > 1.15V	175	275	375	uS
I _{LKG-PGO}	Leakage Current (PGO)	PGO = 5V			5	uA
V _{OL-PGO}	Low Level Output Voltage (PGO)	VDD = 12V I _{sink} 10mA			0.4	V
T _{PG}	Timing PG Delay	PGI to PGO	200	300	450	mS
T _{ND}	Noise Deglitch Time	PGI to PGO	150	250	350	uS

PSON Control

Symbol	Parameter	Test Conditions	Min.	Typ.	Max.	Unit
I _{PSON}	Input Pull-up Current	PSON = 0V		120		uA
V _{IH}	High-level Input Voltage		2			V
V _{IL}	Low-level Input Voltage				0.8	V
T _{PSON}	Timing PSON to On/Off					mS
	On (PSON Low to FPO Low)		34	48	67	
	Off (PSON Hi to PGO Low)		34	48	67	
T _{PSOFF}	Timing PGO Low to FPO high		1.6	2.8	4.5	mS

TYPICAL CHARACTERISTICS

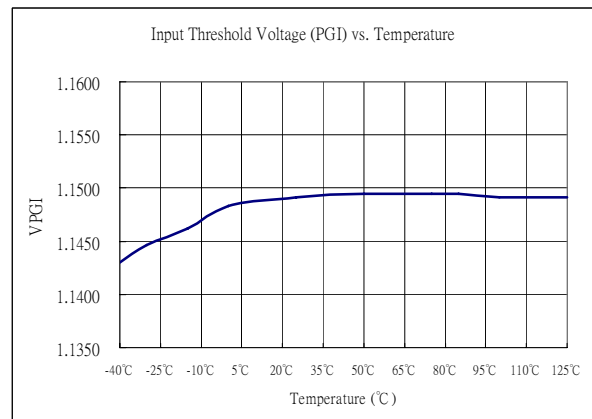
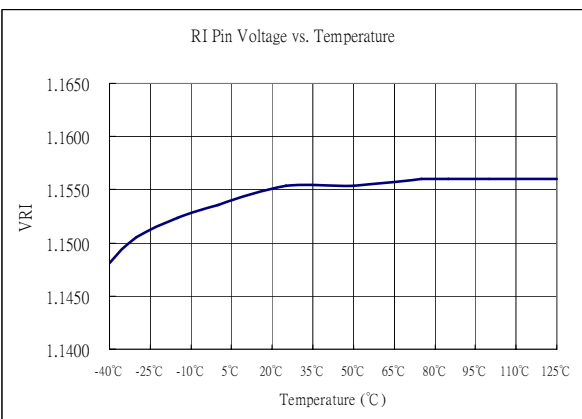
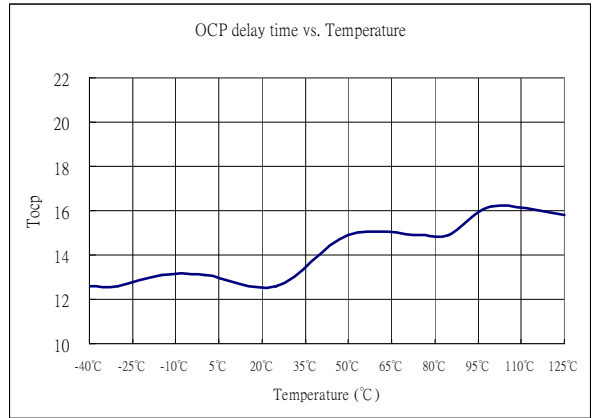
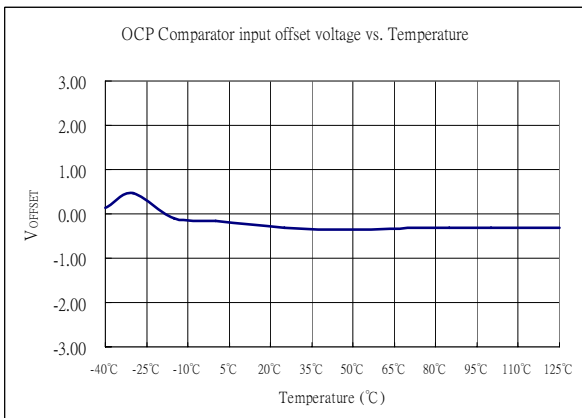
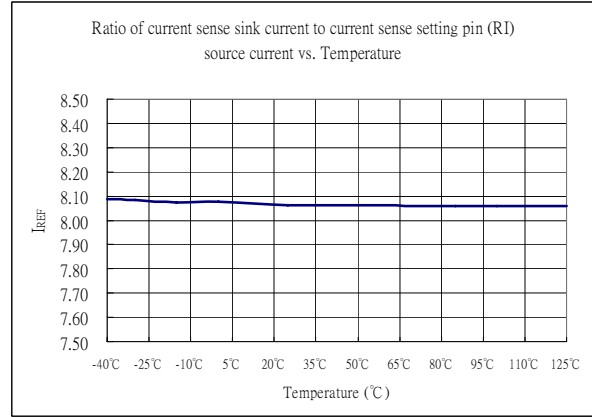
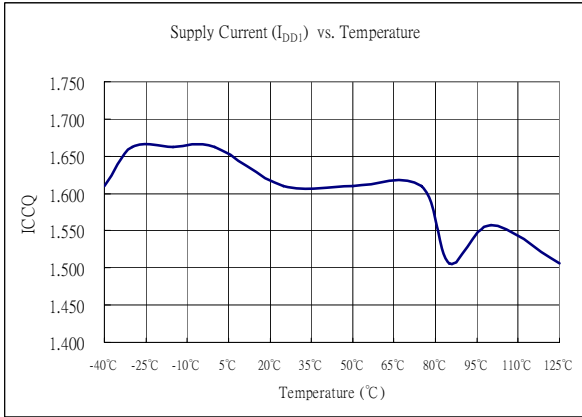

APPLICATION NOTE

Over Current Protection (OCP)

The SG6515 provides over current protection for the 3.3V, 5V and two 12V rails. Whenever an OCP condition occurs at any of the voltage rails, PGO will be low and FPO will be open. The internal OCP comparators have a very small offset voltage ($\pm 5\text{mV}$). The sink currents of IS33, IS5 and IS12 are 8 times the current at the RI pin. The current at the RI pin is V_{RI}/R_i . Here is an example demonstrating how to set the over current protection.

If $I_1 * R_1 > (I_{RI} * 8) * R_2$, than OCP active.

How to select R2 Resistor:

If $R_1 = 5\text{m}\Omega$, $R_i = 30\text{K}$, OCP Protection Level is 35A, than

$$R_2 = (I_1 * R_1) / (I_{RI} * 8)$$

$$= (35\text{A} * 5\text{m}\Omega) / \{(1.15\text{V} / 30\text{K}) * 8\}$$

$$= 570.65\Omega$$

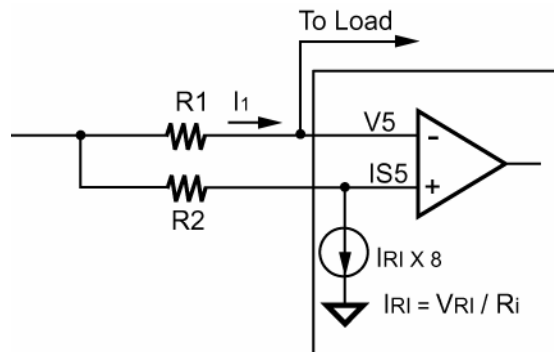

PACKAGE INFORMATION

14 PINS – DIP (D)

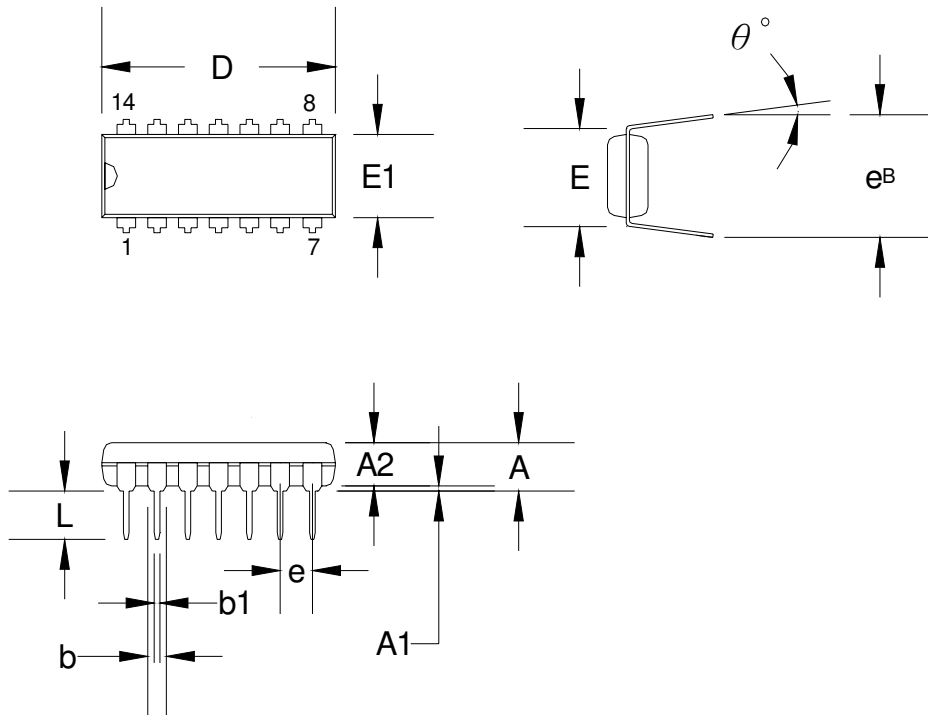

Dimension:

Symbol	Millimeter			Inch		
	Min.	Typ.	Max.	Min.	Typ.	Max.
A			5.334			0.210
A1	0.381			0.015		
A2	3.175	3.302	3.429	0.125	0.130	0.135
b		1.524			0.060	
b1		0.457			0.018	
D	18.669	19.050	19.685	0.735	0.750	0.775
E		7.620			0.300	
E1	6.223	6.350	6.477	0.245	0.250	0.255
e		2.540			0.100	
L	2.921	3.302	3.810	0.115	0.130	0.150
e _B	8.509	9.017	9.525	0.335	0.355	0.375
θ°	0°	7°	15°	0°	7°	15°

14 PINS – SOP (S)

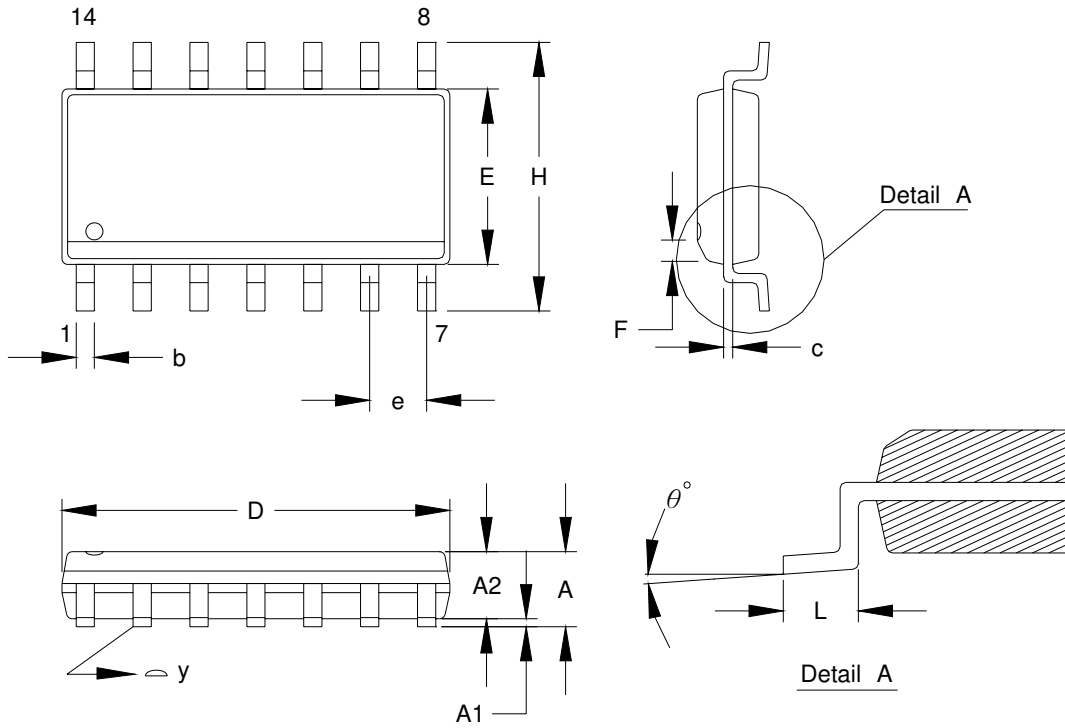

Dimension:

Symbol	Millimeter			Inch		
	Min.	Typ.	Max.	Min.	Typ.	Max.
A	1.473	1.626	1.727	0.058	0.064	0.068
A1	0.101		0.254	0.004		0.010
A2	1.371		1.473	0.054		0.058
b	0.330	0.406	0.508	0.013	0.016	0.020
c	0.190	0.203	0.249	0.0075	0.008	0.0098
D	8.534	8.661	8.484	0.336	0.341	0.344
E	3.810	3.912	3.988	0.150	0.154	0.157
e		1.270			0.050	
H	5.791	5.994	5.690	0.228	0.236	0.244
L	0.381	0.635	1.270	0.015	0.025	0.050
F		0.381X45°			0.015X45°	
y			0.101			0.004
θ°	0°		8°	0°		8°

DISCLAIMERS

LIFE SUPPORT

System General's products are not designed to be used as components in devices intended to support or sustain human life. Use of System General's products in components intended for surgical implant into the body, or other applications in which failure of the System General's products could create a situation where personal death or injury may occur, is not authorized without the express written approval of System General's Chief Executive Officer. System General will not be held liable for any damages or claims resulting from the use of its products in medical applications.

MILITARY

System General's products are not designed for use in military applications. Use of System General's products in military applications is not authorized without the express written approval of System General's Chief Executive Officer. System General will not be held liable for any damages or claims resulting from the use of its products in military applications.

RIGHT TO MAKE CHANGES

System General reserves the right to change this document and/or this product without notice. Customers are advised to consult their System General sales representative before ordering.