

SPECIFICATIONS

(RoHS Compliant)

Model Number: CLE2T2
Part Number: 19020189A

Version: 03
Aug 26, 2019



Mechanical Drawing:

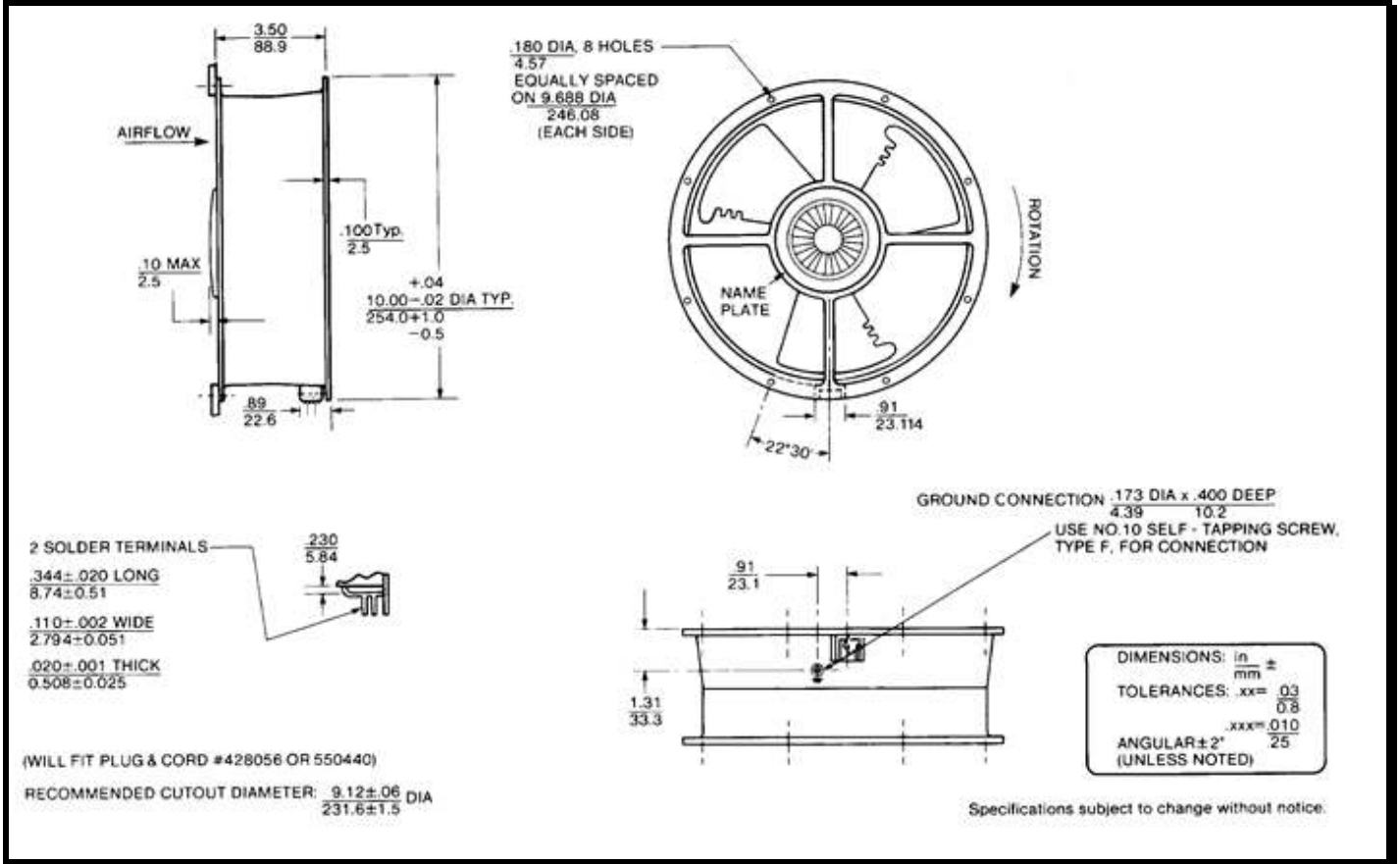

Motor:

Nominal Voltage = 115 VAC
 Frequency = 50 / 60 Hz
 Nominal Running Current = 0.48 / 0.50 amps
 Max. Locked Rotor Current = 1.00 amps
 Running Power = 67 / 61 Watts
 Average Speed = 1400 / 1650 RPM
 Bearings = Ball
 Air Flow = 455 / 550 CFM
 Acoustic: = 45.4 / 49.2 dBA

Construction:

Venturi: Aluminum, Black
 Propeller: Plastic, Black, UL 94V-0

Life Expectancy:

This fan is designed for continuous duty life of 46,000 hours at 70°C.

Additional Features:

Permanent Split Capacitor Motor
 Automatic Reset Thermal Protector
 Class A Insulation
 Feathered Edge Propeller
 Operating Temperature: -10°C to 70°C
 Storage Temperature: -40°C to 85°C

Termination:

2x0.11" Terminals

Agency Approvals:

UL, CUL, CE

PQ Curve:

