

The ISL8510 is a high-performance, triple output controller that provides a single, high frequency power solution for a variety of point of load applications. The ISL8510 integrates a 1A standard buck PWM controller and switching MOSFET with one 500mA LDO.

The PWM controller in the ISL8510 drives an internal switching N-Channel power MOSFET and requires an external Schottky diode to generate an output voltage from 0.6V to 20V. The integrated power switch is optimized for excellent thermal performance up to 1A of output current. The standard buck input voltage range supports a fixed 5V or variable 6V to 25V range. The PWM regulator switches at a fixed frequency of 500kHz and utilizes simple voltage mode control with input voltage feed forward to provide flexibility in component selection and minimize solution size. Protection features include overcurrent, undervoltage, and thermal overload protection integrated into the IC. The ISL8510 power good signal output indicates loss of regulation on the PWM output.

The ISL8510 features adjustable LDO regulator using internal PMOS transistors as pass devices. Enable pin (EN_LDO) control LDO output. A single power good signal output indicates loss of regulation on the LDO output. Independent overcurrent and thermal fault shutdown monitor are integrated into the LDO section.

ISL8510 is available in a small 4mmx4mm thin Quad Flat No-Lead (QFN) package.

Ordering Information

PART NUMBER	PART MARKING	TEMP. RANGE (°C)	PACKAGE	PKG. DWG. #
ISL8510IRZ*	85 10IRZ	-40 to +85	24 Ld QFN 4x4 (2.7 Sq. mm Pad)	L24.4x4D

*Add "-T" suffix for tape and reel

NOTE: Intersil Pb-free plus anneal products employ special Pb-free material sets; molding compounds/die attach materials and 100% matte tin plate termination finish, which are RoHS compliant and compatible with both SnPb and Pb-free soldering operations. Intersil Pb-free products are MSL classified at Pb-free peak reflow temperatures that meet or exceed the Pb-free requirements of IPC/JEDEC J STD-020.

Features

- Standard Buck Controller with Integrated Switching Power MOSFET + 1 LDO
- Integrated Boot Diode
- Input Voltage Range
 - Fixed 5V ±10%
 - Variable 6V to 25V
- PWM Output Voltage Adjustable from 0.6V to 20V with Continuous Output Current up to 1A
- Voltage Mode Control with Voltage Feed Forward
- Fixed 500kHz Switching Frequency
- Externally Adjustable Soft-Start Time
- Output Undervoltage Protection
- LDO Adjustable Options
 - LDO1, 0.6V to 4.2V 500mA
- Individual Enable Inputs
- Two PGOOD Outputs (PWM and LDO)
- Overcurrent Protection
- Thermal Overload Protection
- Internal 5V LDO regulator
- Pb-Free Plus Anneal Available (RoHS Compliant)

Applications

- General Purpose
- WLAN Cards-PCMCIA, Cardbus32, MiniPCI Cards-Compact Flash Cards
- Hand-Held Instruments

Pinout

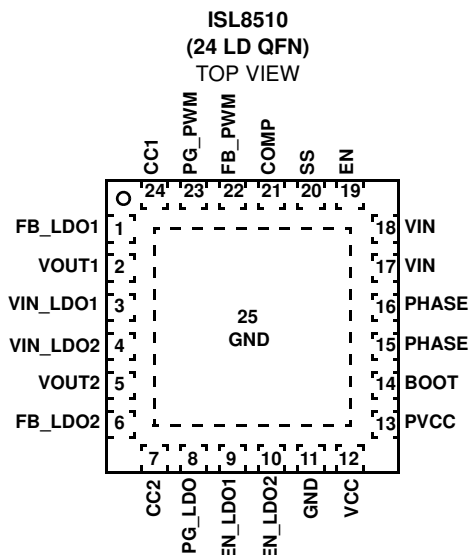

What's Inside

The Evaluation Board Kit contains the following materials:

- The ISL8510 EVAL REV D board
- The ISL8510 datasheet
- This EVAL KIT document

Recommended Equipment

The following materials are recommended to perform testing:

- 0V to 25V power supply with at least 5A source current capability, battery, notebook AC adapter
- Two electronic loads capable of sinking current up to 5A
- Digital Multimeters (DMMs)
- 100MHz quad-trace oscilloscope
- Signal generator

Quick Setup Guide

1. Ensure that the circuit is correctly connected to the supply and loads prior to applying any power.
2. Connect the bias supply to VIN, the plus terminal to TP1 (VCC) and the negative return to TP6 (GND).
3. Verify that SW1 is on ENABLE.
4. Turn on the power supply.
5. Verify the PG_PWM LED is on and that the output voltage is 3.3V for VOUT1 (TP3).
6. Turn on SW2 to ENABLE. If VLDO1 is connected to a separate power supply, remove R25 from the bottom first, then turn on SW2.
7. Verify the PG_LDO LED is on and LDO output voltage is 1.2V for VOUT2 (TP7).

Evaluating the Other Output Voltage

The ISL8510EVAL1Z kit outputs are preset to 3.3V, 1.2V, 1.8V; however, all of them can be programmed using resistor dividers using Equation 1:

$$R_2 = \frac{R_1 \cdot 0.6V}{V_{OUT} - 0.6V} \quad (\text{EQ. 1})$$

The output voltage programming resistor R_2 will depend on the feedback resistor R_1 , as referred to in Figure 1. The value of R_1 is typically between 1k Ω and 10k Ω . If the output voltage desired is 0.6V, then R_2 is left opened.

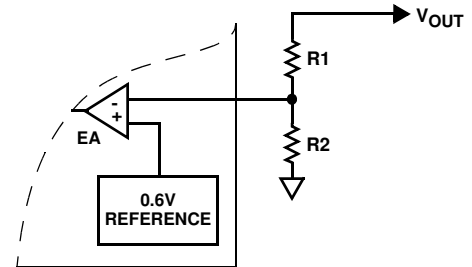
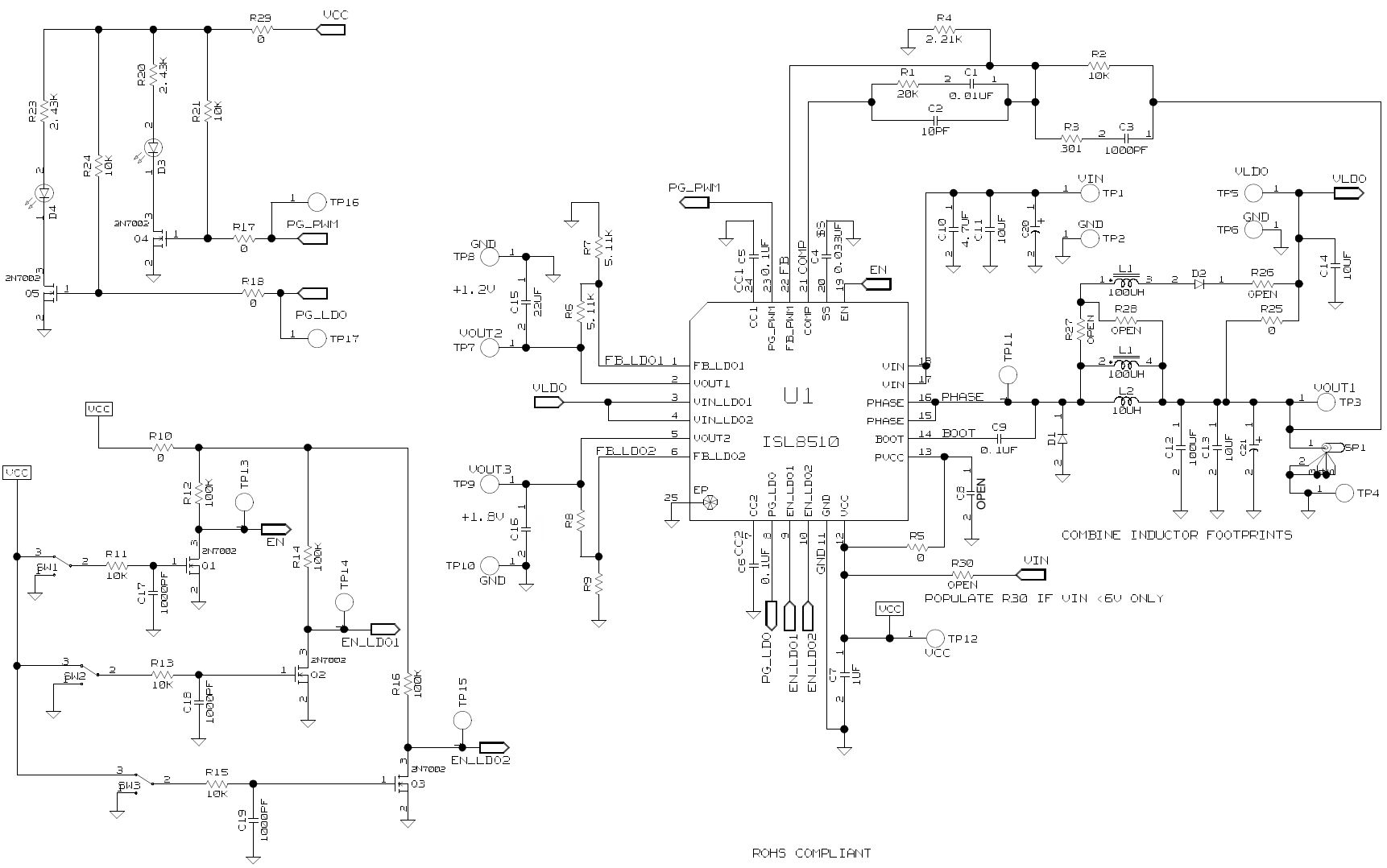

FIGURE 1. EXTERNAL RESISTOR DIVIDER

TABLE 1. SWITCH 1 SETTINGS

SW1	ENABLE	OPERATING MODE
1	SW1	Enable or disable the buck controller
2	SW2	Enable or disable LDO1

iSL8510EVAL1Z Schematic



ROHS COMPLIANT

Application Note 1332

TABLE 2. COMPONENT LIST

REF DES	QTY	VALUE	TOL	VOLTAGE	PACKAGE	PART NUMBER	MANUFACTURER	DESCRIPTION
C5, C6, C9	3	0.10μF	10%	50V	SM 0603	C1608X7R1H104K-T	TDK	CAPACITOR, SMD, 0603, 0.10μF, 50V, 10%, X7R
C11	1	10μF	20%	25V	SM 1210	C3225X7R1E106M-T	TDK	CAP, SMD, 1210, 10μF, 25V, 20%, X7R, ROHS
C2	1	10pF	5%	50V	SM 0402	H1044-00100-50V5-T	VENKEL	CAP, SMD, 0402, 10pF, 50V, 5%, NPO, ROHS
C3, C17-C19	4	1000pF	10%	50V	SM 0402	H1044-00102-50V10-T	VENKEL, PANASONIC, MURATA	CAP, SMD, 0402, 1000pF, 50V, 10%, X7R, ROHS
C1	1	0.01μF	10%	16V	SM 0402	H1044-00103-16V10-T	NIC COMP CORP, PHILLIPS, VENKEL, KEMET	CAP, SMD, 0402, 0.01μF, 16V, 10%, X7R, ROHS
C4	1	33000pF	20%	16V	SM 0402	H1044-00333-16V8020-T	PANASONIC	CAP, SMD, 0402, 33000pf, 16V, +80-20%, Y5V, ROHS
C14	1	10μF	10%	6.3V	SM 0805	H1046-00106-6R3V10-T	VENKEL, AVX, MURATA	CAP, SMD, 0805, 10μF, 6.3V, 10%, X5R, ROHS
C7	1	1μF	10%	50V	SM 1206	H1065-00105-50V10-T	VENKEL	CAP, SMD, 1206, 1μF, 50V, 10%, X7R, ROHS
C8	1	DNP	10%	50V	SM 1206	H1065-00105-50V10-T	VENKEL	CAP, SMD, 1206, 1μF, 50V, 10%, X7R, ROHS
C13	1	10μF	10%	25V	SM 1206	H1065-00106-25V10-T	VENKEL	CAP, SMD, 1206, 10μF, 25V, 10%, X5R, ROHS
C15	1	22μF	10%	6.3V	SM 1206	H1065-00226-6R3V10-T	MURATA, KEMET, AVX	CAP, SMD, 1206, 22μF, 6.3V, 10%, X5R, ROHS
C16	1	DNP	10%	6.3V	SM 1206	H1065-00226-6R3V10-T	MURATA, KEMET, AVX	CAP, SMD, 1206, DNP, DNP, DNP, X5R, ROHS
C10	1	4.7pF	5.40%	50V	SM 1206	H1065-004R7-50VR25-T	VENKEL	CAP, SMD, 1206, 4.7pF, 50V, 0.25pF, NPO, ROHS
C12	1	100μF	20%	6.3V	SM 1210	H1082-00107-6R3V20-T	GENERIC	CAP, SMD, 1210, 100μF, 6.3V, 20%, X5R, ROHS
L2	1	10μH	20%	102mΩ	6.9x6.5	IHLP-2525CZ-ER-10R-M01	VISHAY	COIL-PWR INDUCTOR, SMD, 6.9mmx6.5mm, 10μH, 20%, 3A, ROHS
DNP (SP1)	0	DNP	-	-	-	131-5031-00	TEKTRONIX	CONN-SCOPE PROBE TEST PT, COMPACT, PCB MNT
TP1-TP8	8	-	-	-	-	1514-2	KEYSTONE	CONN-TURRET, TERMINAL POST, TH, ROHS
TP9-TP10	2	DNP	-	-	-	1514-2	KEYSTONE	CONN-TURRET, TERMINAL POST, TH, ROHS
TP11-TP14, TP16-TP17	6	-	-	-	-	5002	KEYSTONE	CONN-MINI TEST POINT, VERTICAL, WHITE, ROHS
TP15	1	DNP	-	-	-	5002	KEYSTONE	CONN-MINI TEST POINT, VERTICAL, WHITE, ROHS
D1	1	-	-	-	-	B340LB-13-F-T	DIODES INC	DIODE-SCHOTTKY, SMD, SMB, 2P, 40V, 3A LOW VF, Pb-free
D3, D4	2	-	-	-	-	LTST-C170CKT	LITEON, VISHAY, ROHM, STANLEY ELECTRIC	LED-GaAs RED, SMD, 2mmx1.25mm, 100mW, 40mA, 10mcd, ROHS

Application Note 1332

TABLE 2. COMPONENT LIST (Continued)

REF DES	QTY	VALUE	TOL	VOLTAGE	PACKAGE	PART NUMBER	MANUFACTURER	DESCRIPTION
U1	1	-	-	-	QFN	ISL8510IRZ	INTERSIL	IC-2A BUCK REGULATOR, 24P, QFN, 4x4, ROHS
Q1-Q5	5	-	-	60V	SOT-23	2N7002-7-F-T	DIODES, INC, ON SEMICONDUCTOR	TRANSISTOR, N-CHANNEL, 3 LD, SOT-23, 60V, 115mA, ROHS
R17, R18	2	0Ω	5%	50V	SM 0402	H2510-00R00-1/16W-T	VENKEL, PANASONIC	RES, SMD, 0402, 0Ω, 1/16W, 5%, TF, ROHS
R2, R11, R13, R15	4	10k	1%	50V	SM 0402	H2510-01002-1/16W1-T	PANASONIC, VENKEL	RES, SMD, 0402, 10k, 1/16W, 1%, TF, ROHS
R12, R14, R16	3	100k	1%	50V	SM 0402	H2510-01003-1/16W1-T	PANASONIC	RES, SMD, 0402, 100k, 1/16W, 1%, TF, ROHS
R1	1	20k	1%	50V	SM 0402	H2510-02002-1/16W1-T	PANASONIC	RES, SMD, 0402, 20k, 1/16W, 1%, TF, ROHS
R4	1	2.21k	1%	50V	SM 0402	H2510-02211-1/16W1-T	PANASONIC, VENKEL	RES, SMD, 0402, 2.21k, 1/16W, 1%, TF, ROHS
R8-R9	2	DNP	1%	50V	SM 0402	H2510-02551-1/16W1-T	VENKEL, VISHAY, DALE	RES, SMD, 0402, DNP, DNP, DNP, TF, ROHS
R3	1	301Ω	1%	50V	SM 0402	H2510-03010-1/16W1-T	PANASONIC, VENKEL	RES, SMD, 0402, 301Ω, 1/16W, 1%, TF, ROHS
R6-R7	2	5.11k	1%	50V	SM 0402	H2510-05111-1/16W1-T	PANASONIC	RES, SMD, 0402, 5.11k, 1/16W, 1%, TF, ROHS
R5, R10, R29	3	0Ω	1%	75V	SM 0603	H2511-00R00-1/10W-T	GENERIC	RESISTOR, SMD, 0603, 0Ω, 1/10W, TF, ROHS
R21, R24	2	10k	1%	75V	SM 0603	H2511-01002-1/10W1-T	KOA, VENKEL	RES, SMD, 0603, 10k, 1/10W, 1%, TF, ROHS
R20, R23	2	2.43k	1%	75V	SM 0603	H2511-02431-1/10W1-T	VENKEL, YAGEO	RES, SMD, 0603, 2.43k, 1/10W, 1%, TF, ROHS
R25	1	0Ω	1%	200V	SM 1206	H2513-00R00-1/4W-T	VISHAY, VENKEL	RES, SMD, 1206, 0Ω, 1/4W, TF, ROHS
R26-R28, R30	0	DNP	1%	200V	SM 1206	H2513-DNP	GENERIC	RES, SMD, 1206, DNP, DNP, DNP, TF, ROHS
SW1-SW2	2	-	-	-	-	GT11MSCBE-T	C&K COMPONENTS	SWITCH-TOGGLE, SMD, ULTRAMINI, 1P, SPST MINI
SW3	1	DNP	-	-	-	GT11MSCBE-T	C&K COMPONENTS	SWITCH-TOGGLE, SMD, ULTRAMINI, 1P, SPST MINI
C20, C21	0	DNP	-	-	-	DNP		DO NOT POPULATE OR PURCHASE
D2	0	DNP	-	-	-	DNP		DO NOT POPULATE OR PURCHASE
L1	0	DNP	-	-	-	DNP		DO NOT POPULATE OR PURCHASE

ISL8510EVAL1Z Board Layout

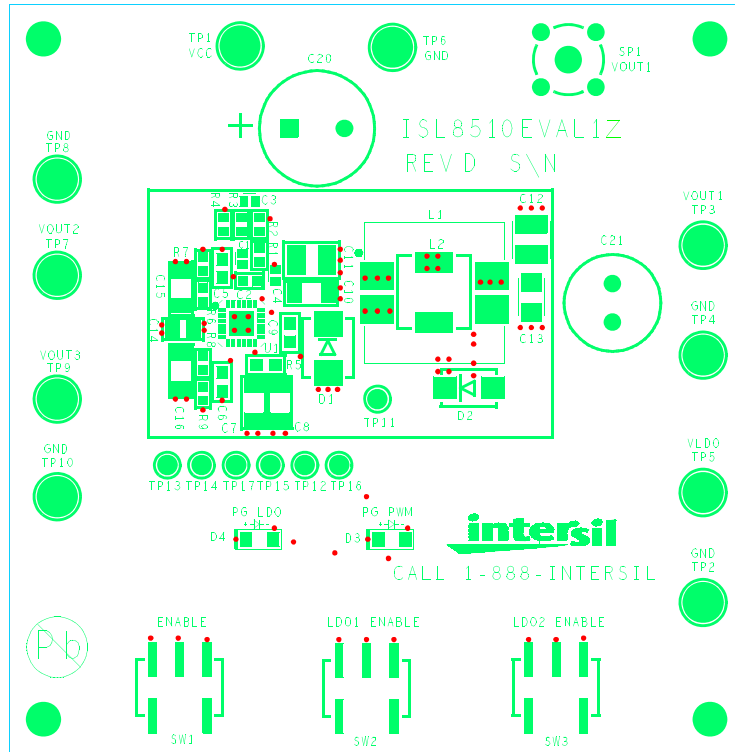

FIGURE 2. TOP COMPONENTS

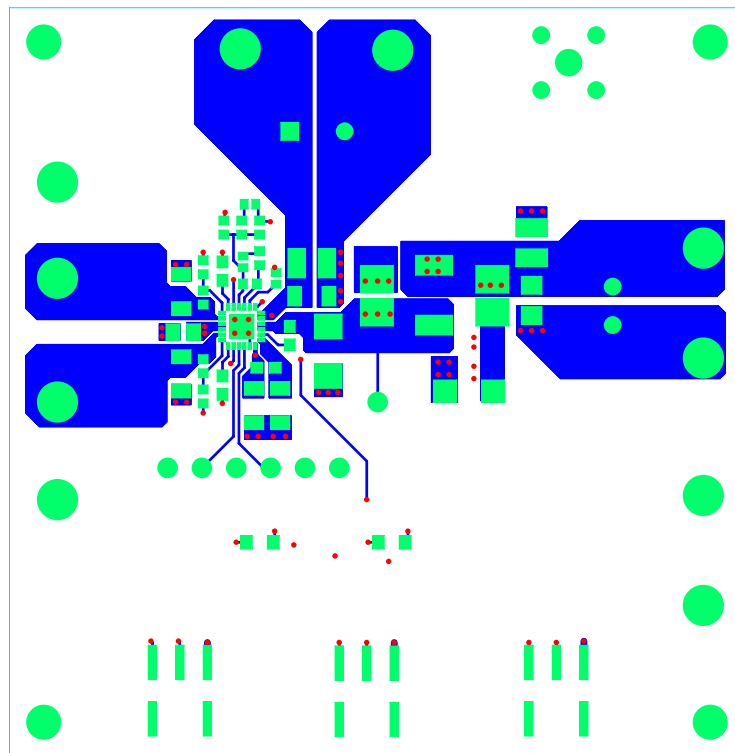

FIGURE 3. TOP LAYER ETCH

ISL8510EVAL1Z Board Layout (Continued)

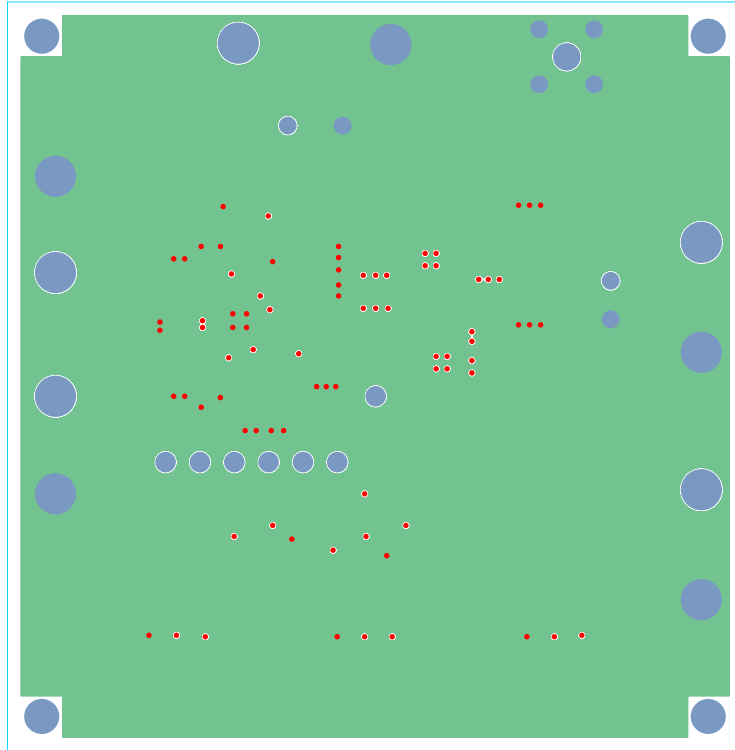

FIGURE 4. 2ND LAYER ETCH

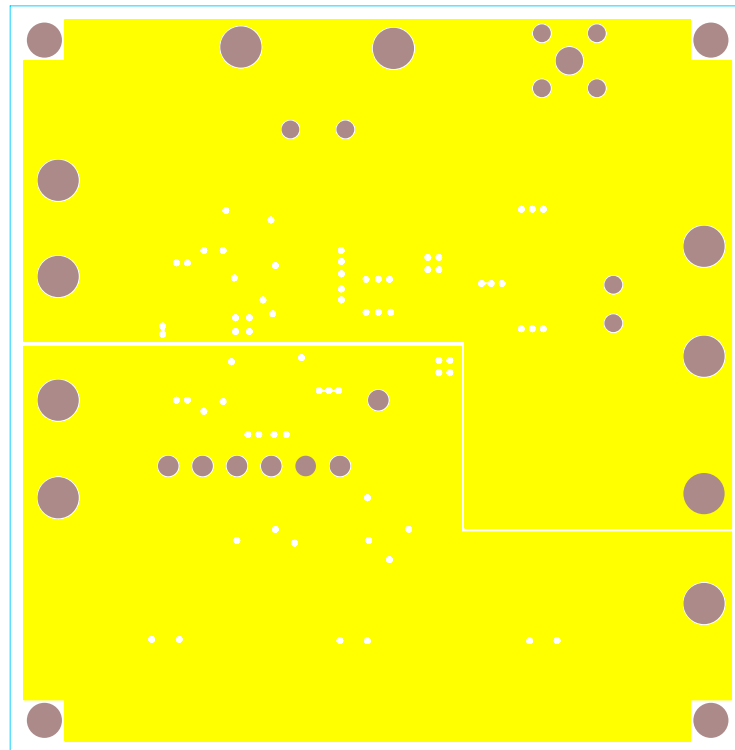

FIGURE 5. 3RD LAYER ETCH

ISL8510EVAL1Z Board Layout (Continued)

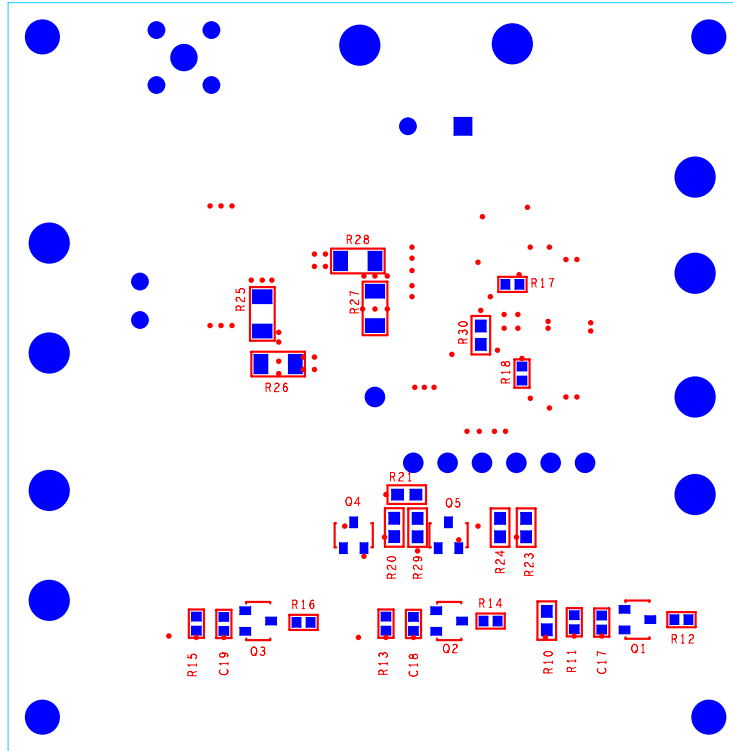

FIGURE 6. BOTTOM LAYER COMPONENTS (MIRRORED)

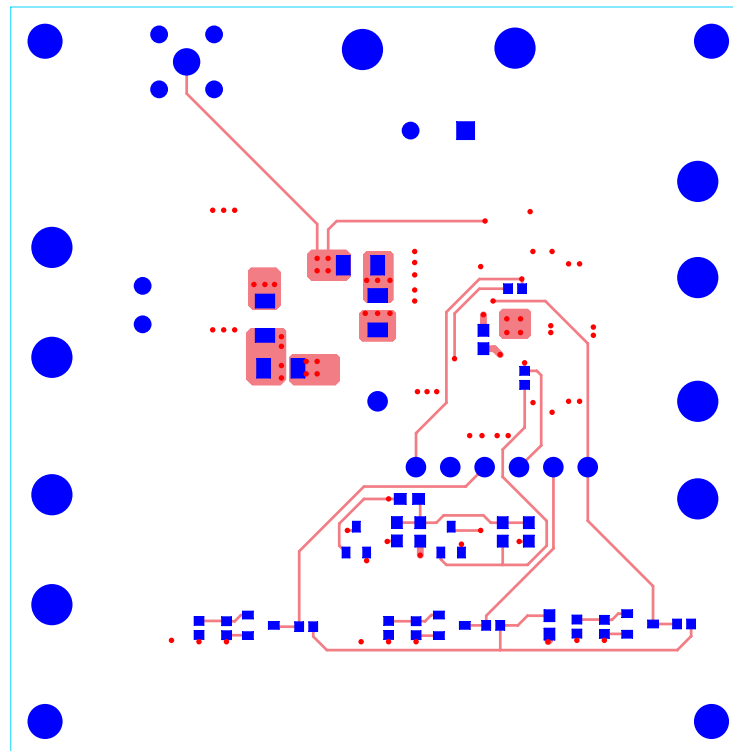

FIGURE 7. BOTTOM LAYER ETCH (MIRRORED)

Intersil Corporation reserves the right to make changes in circuit design, software and/or specifications at any time without notice. Accordingly, the reader is cautioned to verify that the Application Note or Technical Brief is current before proceeding.

For information regarding Intersil Corporation and its products, see www.intersil.com