



HA-2510, HA-2512 HA-2515

March 1993

High Slew Rate Operational Amplifiers

Features

- High Rate Slew 60V/ μ s
- Fast Settling 250ns
- Wide Power Bandwidth 1,000kHz
- High Gain Bandwidth 12MHz
- High Input Impedance 100M Ω
- Low Offset Current 10nA
- Internally Compensated for Unity Gain Stability

Applications

- Data Acquisition Systems
- R.F. Amplifiers
- Video Amplifiers
- Signal Generators
- Pulse Amplification

Description

HA-2510/12/15 are a series of high performance operational amplifiers which set the standards for maximum slew rate, highest accuracy and widest bandwidths for internally compensated monolithic devices. In addition to excellent dynamic characteristics, these dielectrically isolated amplifiers also offer low offset current and high input impedance.

The $\pm 60\text{V}/\mu\text{s}$ slew rate and 250ns (0.1%) settling time of these amplifiers is ideally suited for high speed D/A, A/D, and pulse amplification designs. HA-2510/12/15's superior 12MHz gain bandwidth and 1000kHz power bandwidth is extremely useful in R.F. and video applications. For accurate signal conditioning these amplifiers also provide 10nA offset current, coupled with 100M Ω input impedance, and offset trim capability.

Mil-Std-883 product and data sheets are available upon request.

Ordering Information

PART NUMBER	TEMP. RANGE	PACKAGE
HA2-2510-2	-55°C to +125°C	8 Pin Can
HA2-2512-2	-55°C to +125°C	8 Pin Can
HA2-2515-5	0°C to +75°C	8 Pin Can
HA3-2515-5	0°C to +75°C	8 Lead Plastic DIP
HA7-2510-2	-55°C to +125°C	8 Lead Ceramic DIP
HA7-2512-2	-55°C to +125°C	8 Lead Ceramic DIP
HA7-2515-5	0°C to +75°C	8 Lead Ceramic DIP

Pinouts

HA-2510/12 (CDIP)
HA-2515 (PDIP, CDIP)
TOP VIEW

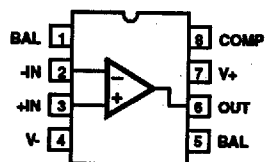

HA-2510/12/15 (TO-99 CAN)
TOP VIEW

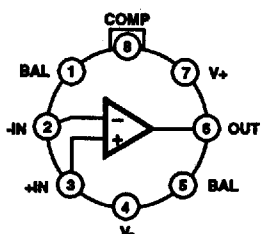

Schematic

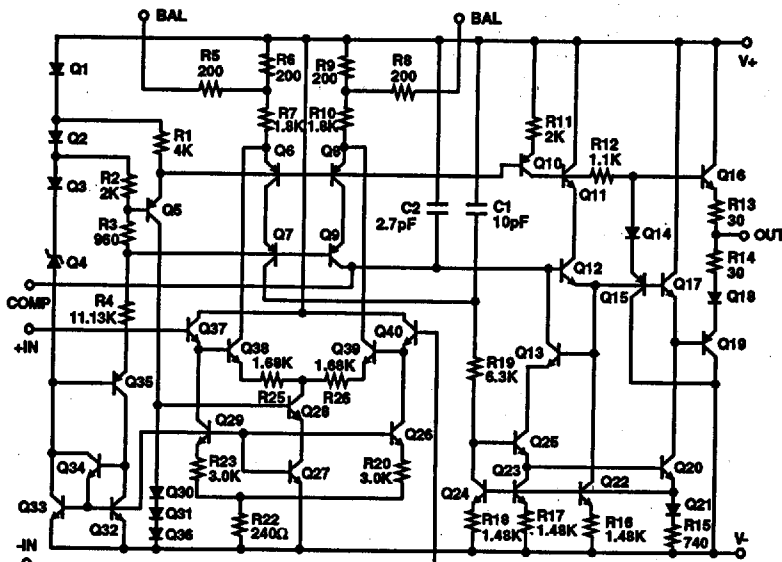

CAUTION: These devices are sensitive to electrostatic discharge. Users should follow proper I.C. Handling Procedures.
Copyright © Harris Corporation 1993

File Number 2893.1

Specifications HA-2510, HA-2512, HA-2515

Absolute Maximum Ratings (Note 6)

Voltage Between V+ and V- Terminals	40.0V
Differential Input Voltage	15V
Peak Output Current	50mA
Junction Temperature	+175°C
Junction Temperature (Plastic Package)	+150°C
Lead Temperature (Soldering 10 Sec.)	+300°C

Operating Conditions

Operating Temperature Range	-55°C ≤ T _A ≤ +125°C
HA-2510/12-2	-55°C ≤ T _A ≤ +125°C
HA-2515-5	0°C ≤ T _A ≤ +75°C
Storage Temperature Range	-65°C ≤ T _A ≤ +150°C

CAUTION: Stresses above those listed in "Absolute Maximum Ratings" may cause permanent damage to the device. This is a stress only rating and operation of the device at these or any other conditions above those indicated in the operational sections of this specification is not implied.

Electrical Specifications V+ = +15VDC, V- = -15VDC

PARAMETER	TEMP	HA-2510-2			HA-2512-2			HA-2515-5			UNITS
		MIN	TYP	MAX	MIN	TYP	MAX	MIN	TYP	MAX	
INPUT CHARACTERISTICS											
Offset Voltage	+25°C	-	4	8	-	5	10	-	5	10	mV
	Full	-	-	11	-	-	14	-	-	14	mV
Offset Voltage Average Drift	Full	-	20	-	-	25	-	-	30	-	μV/°C
Bias Current	+25°C	-	100	200	-	125	250	-	125	250	nA
	Full	-	-	400	-	-	500	-	-	500	nA
Offset Current	+25°C	-	10	25	-	20	50	-	20	50	nA
	Full	-	-	50	-	-	100	-	-	100	nA
Input Resistance (Note 10)	+25°C	50	100	-	40	100	-	40	100	-	MΩ
Common Mode Range	Full	±10.0	-	-	±10.0	-	-	±10.0	-	-	V
TRANSFER CHARACTERISTICS											
Large Signal Voltage Gain (Notes 1, 4)	+25°C	10	15	-	7.5	15	-	7.5	15	-	KV/V
	Full	7.5	-	-	5	-	-	5	-	-	KV/V
Common Mode Rejection Ratio (Note 2)	Full	80	90	-	74	90	-	74	90	-	dB
Gain Bandwidth Product (Notes 3)	+25°C	-	12	-	-	12	-	-	12	-	MHz
OUTPUT CHARACTERISTICS											
Output Voltage Swing (Note 1)	Full	±10.0	±12.0	-	±10.0	±12.0	-	±10.0	±12.0	-	V
Output Current (Note 4)	+25°C	±10	±20	-	±10	±20	-	±10	±20	-	mA
Full Power Bandwidth (Notes 4, 11)	+25°C	750	1000	-	600	1000	-	600	1000	-	kHz
TRANSIENT RESPONSE											
Rise Time (Notes 1, 5, 7, 8)	+25°C	-	25	50	-	25	50	-	25	50	ns
Overshoot (Notes 1, 5, 7, 8)	+25°C	-	25	40	-	25	50	-	25	50	%
Slew Rate (Notes 1, 5, 8, 12)	+25°C	±50	±65	-	±40	±60	-	±40	±60	-	V/μs
Settling Time to 0.1% (Notes 1, 5, 8, 12)	+25°C	-	0.25	-	-	0.25	-	-	0.25	-	μs
POWER SUPPLY CHARACTERISTICS											
Supply Current	+25°C	-	4	6	-	4	6	-	4	6	mA
Power Supply Rejection Ratio (Note 19)	Full	80	90	-	74	90	-	74	90	-	dB

NOTES:

- R_L = 2kΩ
- V_{CM} = ±10VDC
- A_V > 10.
- V_O = ±10V.
- C_L = 50pF.
- Absolute Maximum Ratings are limiting values, applied individually, beyond which the serviceability of the circuit may be impaired.
- V_O = ±200mV.
- See Transient Response Test Circuits and Waveforms.
- ΔV = ±5V.
- This parameter value is based on design calculations.
- Full Power Bandwidth guaranteed based on slew rate measurement using: FPBW = Slew Rate/2πV_{PEAK}.
- V_{OUT} = ±5V.

2
OPERATIONAL AMPLIFIERS

HA-2510, HA-2512, HA-2515

Die Characteristics

Transistor Count	40	
Die Dimensions	57 x 65 x 19 mils	
Substrate Potential	Unbiased	
Process	Bipolar-DI	
Thermal Constants (°C/W)	θ_{JA}	θ_{JC}
Metal Can.....	117	36
Plastic Mini-DIP	96	34
Ceramic Mini-DIP.....	115	36

Settling Time Circuit

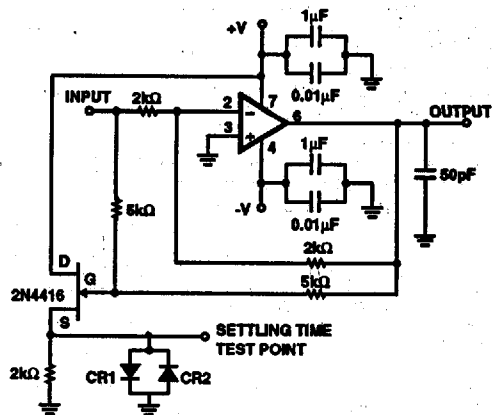

- $A_v = -1$
- Feedback and summing resistor ratios should be 0.1% matched.
- Clipping diodes CR1 and CR2 are optional. HP5062-2810 recommended.

Test Circuits

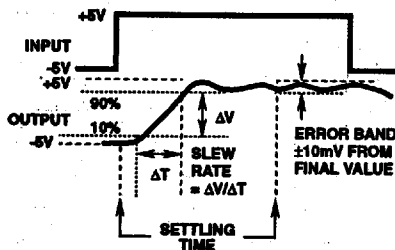

FIGURE 1. SLEW RATE AND SETTLING TIME

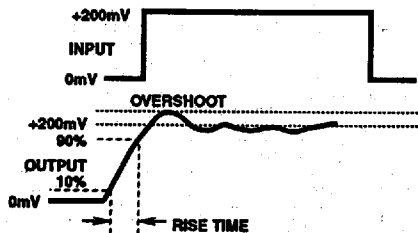

FIGURE 2. TRANSIENT RESPONSE

NOTE: Measured on both positive and negative transitions from 0V to +200mV and 0V to -200mV at the output.

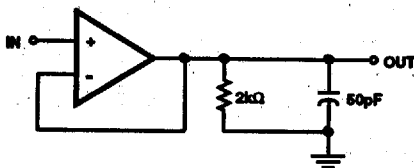

FIGURE 3. SLEW RATE AND TRANSIENT RESPONSE

NOTE: Measured on both positive and negative transitions from 0V to +200mV and 0V to -200mV at the output.

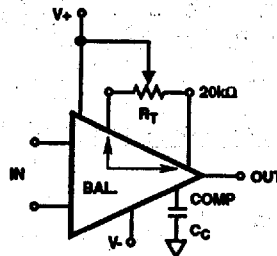

FIGURE 4. SUGGESTED V_{OS} ADJUSTMENT AND COMPENSATION HOOK UP

Tested offset adjustment range is $|V_{OS} + 1mV|$ minimum referred to output. Typical ranges are $\pm 6mV$ with $R_T = 20k\Omega$

Typical Performance Curves

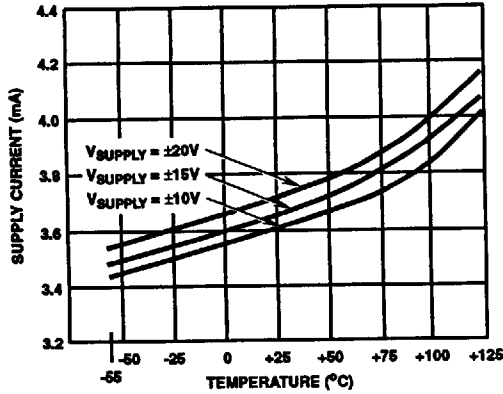
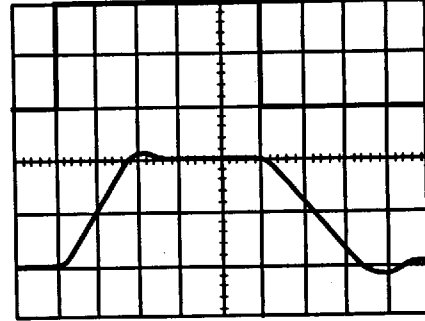

FIGURE 5. POWER SUPPLY CURRENT vs TEMPERATURE



$R_L = 2k\Omega$, $C_L = 50pF$ Vertical = 5V/Div.
 Upper Trace: Input Horizontal = 200ns/Div.
 Lower Trace: Output $T_A = +25^\circ C$, $V_S = \pm 15V$

FIGURE 6. VOLTAGE FOLLOWER PULSE RESPONSE

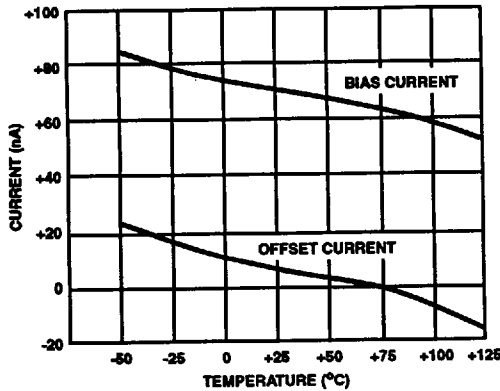

FIGURE 7. INPUT BIAS AND OFFSET CURRENT vs TEMPERATURE

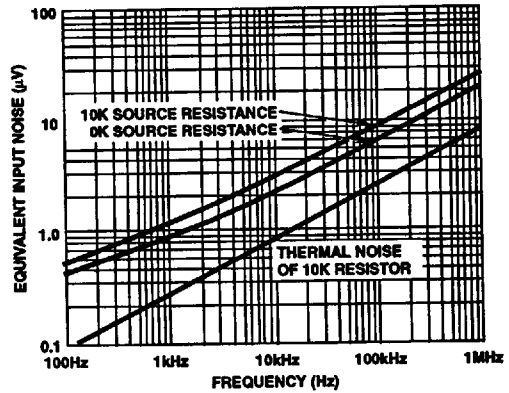

FIGURE 8. EQUIVALENT INPUT NOISE vs BANDWIDTH (WITH 10Hz HIGH PASS FILTER)

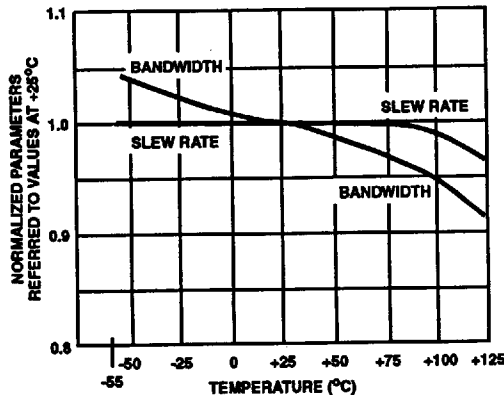

FIGURE 9. NORMALIZED AC PARAMETERS vs TEMPERATURE

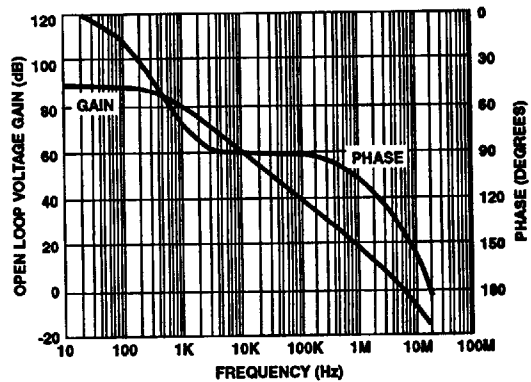

FIGURE 10. OPEN LOOP GAIN AND PHASE RESPONSE

HA-2510, HA-2512, HA-2515

Typical Performance Curves (Continued)

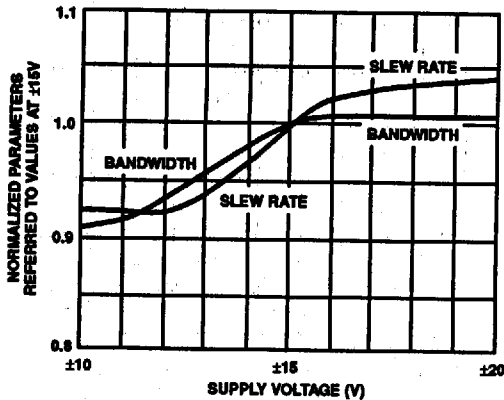

FIGURE 11. NORMALIZED AC PARAMETERS vs SUPPLY VOLTAGE AT +25°C

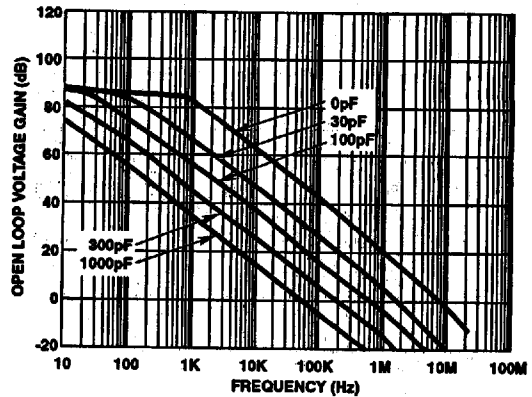

FIGURE 12. OPEN LOOP GAIN RESPONSE FOR VARIOUS VALUES OF CAPACITORS FROM COMPENSATION PIN TO GROUND

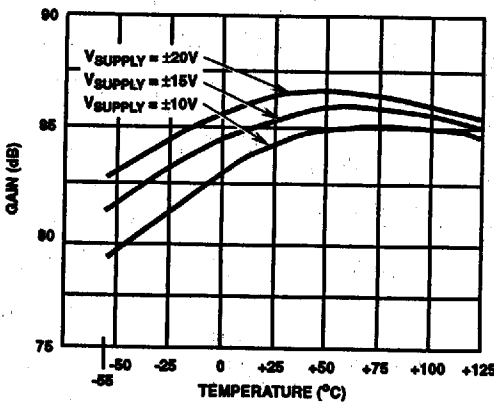

FIGURE 13. OPEN LOOP VOLTAGE GAIN vs TEMPERATURE

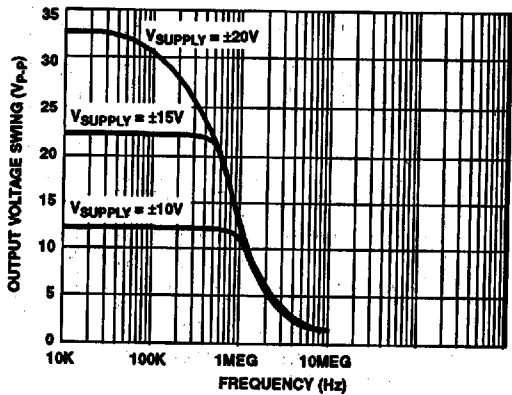

FIGURE 14. OUTPUT VOLTAGE SWING vs FREQUENCY AT +25°C